



Madison, Wisconsin

INDEX OF SHEETS

| SHEET NO. | TITLE |
|-----------|---------------------------------|
| 1 | |
| DI-D6 | DETAILS |
| ECl-EC10 | EROSION CONTROL PLANS |
| P1-P6 | COTTAGE GROVE RD PLAN & PROF. |
| P7-P10 | DEMPSEY RD PLAN & PROFILE |
| M1-M7 | PAVEMENT MARKING PLANS |
| U1-U10 | SEWER PLAN & PROFILES |
| UII-U14 | SEWER SCHEDULES |
| U15 | BORE AND JACK CASING DETAILS |
| W1-W10 | WATER PLAN & PROFILE |
| W11-W13 | WATER IMPACT PLANS |
| W14 | WATER MATERIALS AND DETAILS |
| E1-E11 | ELECTRICAL PLAN |
| TC1-TC18 | TRAFFIC CONTROL PLAN |
| X1-X21 | COTTAGE GROVE RD CROSS SECTIONS |
| X22-X35 | DEMPSEY ROAD CROSS SECTIONS |

CITY OF MADISON

CITY ENGINEERING DIVISION

DEPARTMENT OF PUBLIC WORKS

PLAN OF PROPOSED IMPROVEMENT

COTTAGE GROVE ROAD AND DEMPSEY ROAD STREET ASSESSMENT DISTRICT - 2016

CITY PROJECT NO. 53W1681

MUNIS NO. 10250

CITY CONTRACT NO. 7462

PUBLIC IMPROVEMENT PROJECT APPROVED

JANUARY 5, 2016

BY THE COMMON COUNCIL OF MADISON, WISCONSIN

PUBLIC IMPROVEMENT DESIGN APPROVED BY:

[Signature] 2/25/16
 City Engineer Date

PAVEMENT MARKING DESIGNED BY:

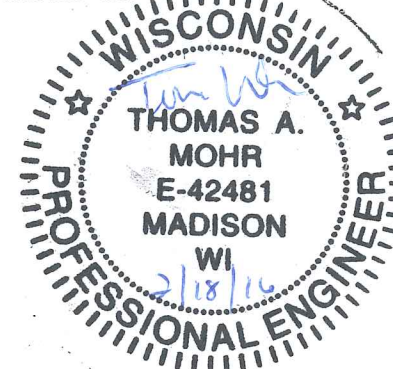

STREET DESIGNED BY:

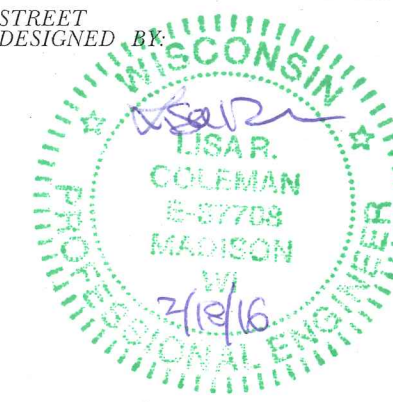

GEOMETRICS DESIGNED BY:



SANITARY AND STORM SEWER DESIGNED BY:

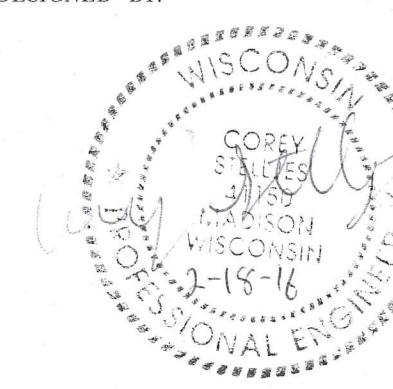

STREET LIGHTING & SIGNALS DESIGNED BY:

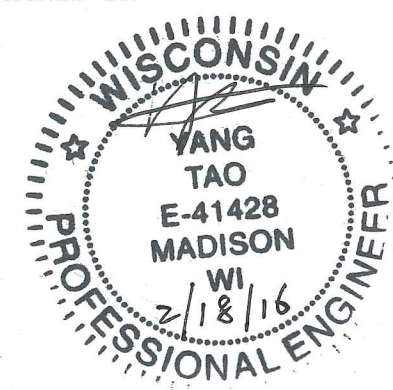

WATER DESIGNED BY:

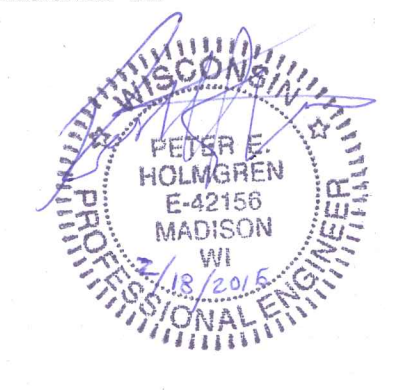

CONVENTIONAL SIGNS
 FIELD VERIFY ALL UTILITY LOCATIONS

| | |
|---------------------------------------------------|----------|
| GAS | — G — |
| STORM SEWER | — ST — |
| SANITARY SEWER | — SAN — |
| WATER | — W — |
| OVERHEAD ELECTRIC | — OH — |
| POWER POLE | ⊕ |
| ADA COMPLIANT RAMP W/ DETECTABLE WARNING FIELD | [Symbol] |
| COMBUSTIBLE FLUIDS | [Symbol] |

CONSTRUCTION PROJECT LOCATION

NOTES:

ALL GUTTERS SHALL DRAIN WITH A MINIMUM GRADE OF 0.50% TOWARD STORM SEWER INLETS.

SIDEWALK RAMPS AND CURB THRU SIDEWALK RAMPS SHALL HAVE A MAXIMUM SLOPE OF 1" PER 12". SIDEWALK AND CURB RAMPS SHALL BE CONSTRUCTED WITH A SIDE SLOPE OF 2.00%.

SIDEWALK SHALL HAVE A MINIMUM LONGITUDINAL SLOPE OF 0.50% AND A MAXIMUM LONGITUDINAL SLOPE OF 5.00% EXCEPT WHERE STREET GRADES EXCEED 5.00%.

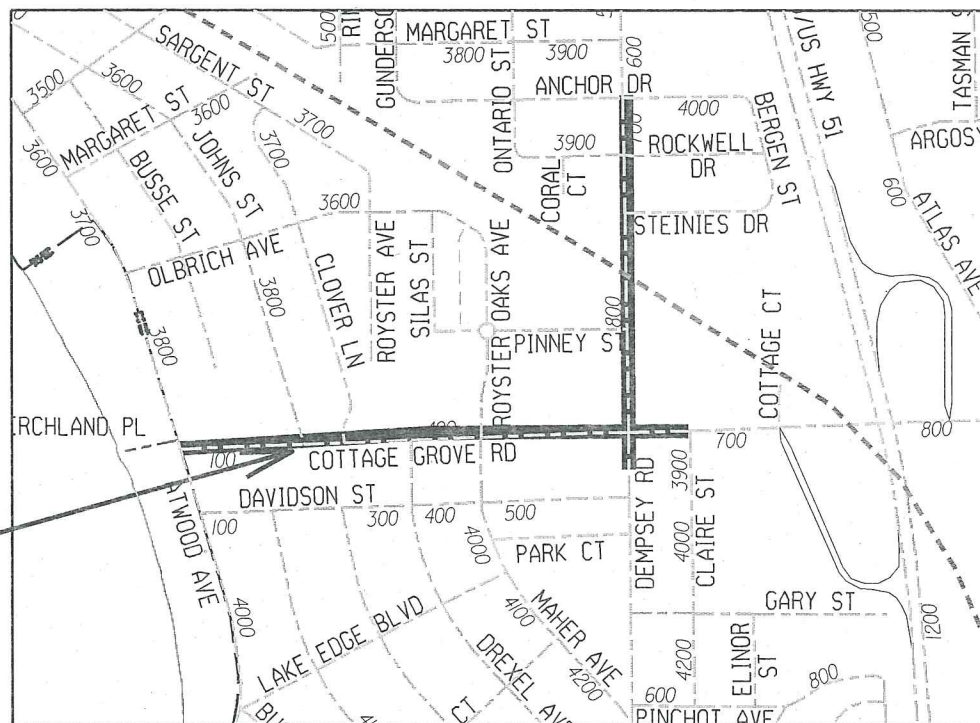
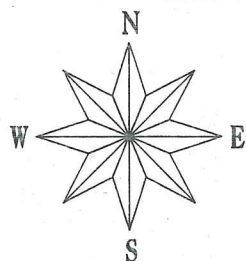

EARTH WORK SUMMARY:

| | |
|----------------------------------------------|------------|
| EXCAVATION CUT (MEASURED PLAN QUANTITY)..... | 13900 C.Y. |
| ESTIMATED UNDISTRIBUTED UNDERCUT..... | 3650 C.Y. |
| TOTAL UNCLASSIFIED EXCAVATION CUT..... | 17550 C.Y. |

PLOT SCALE:

REV. DATE:

ORIGINATOR: CITY OF MADISON, STREETS DIVISION

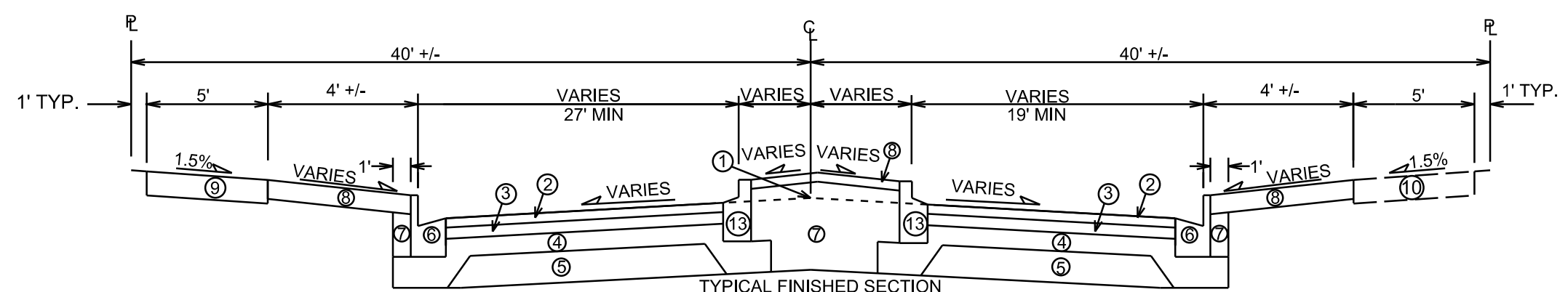
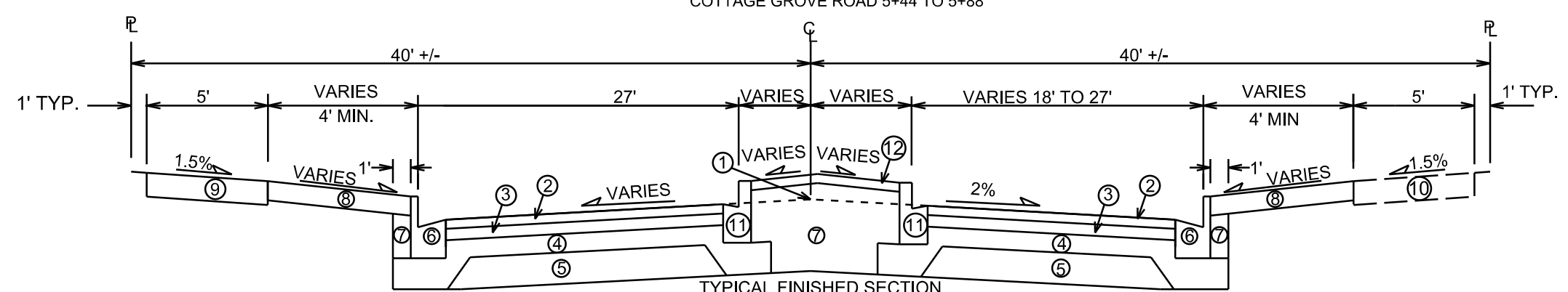
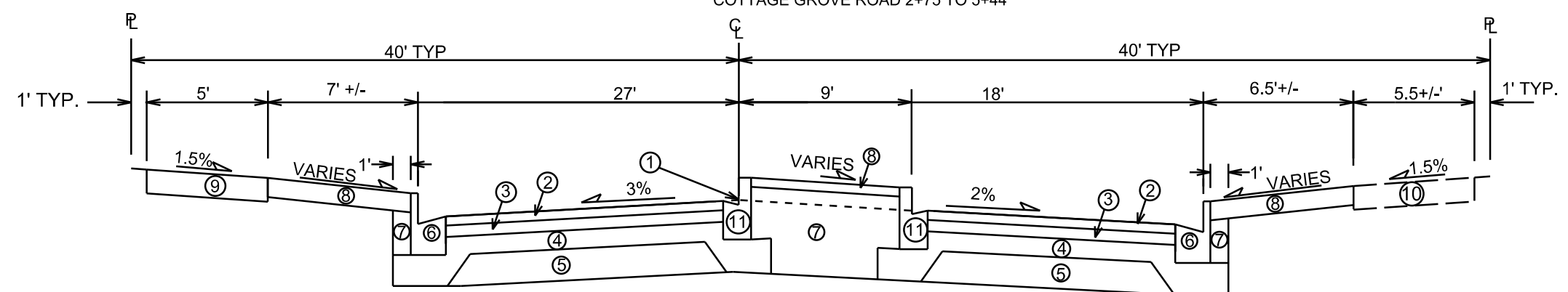
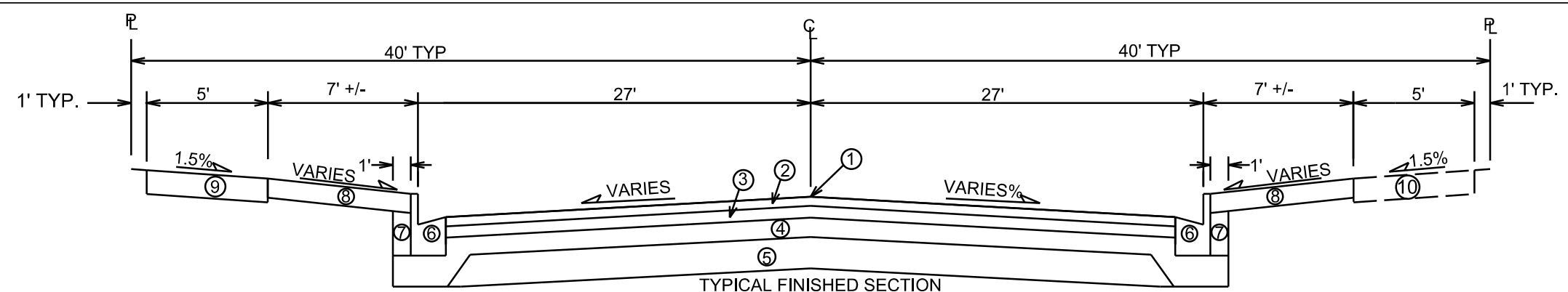

- ① POINT REFERRED TO ON PROFILE
- ② 3.00" BITUMINOUS UPPER LAYER, TYPE E-3, 12.5 mm
- ③ 3.00" BITUMINOUS LOWER LAYER, TYPE E-3, 19 mm
- ④ 8" GRADATION 2 CRUSHED STONE
- ⑤ 8" GRADATION 1 CRUSHED STONE
- ⑥ TYPE 'A' CONCRETE CURB & GUTTER
- ⑦ FILL, INCIDENTAL
- ⑧ 4" TOPSOIL, SEED & MAT
- ⑨ 5" CONCRETE SIDEWALK
- ⑩ EXISTING SIDEWALK, SEE PLAN FOR SPOT REPLACE
- ⑪ TYPE 'H' CONCRETE CURB & GUTTER
- ⑫ 7" STAMPED & COLORED CONCRETE
- ⑬ TYPE 'E' CONCRETE CURB & GUTTER

TYPICAL SECTIONS NOT TO SCALE

PLOT SCALE: _____
PLOT NAME: _____
REV. DATE: _____
ORIGINATOR: CITY OF MADISON, STREETS DIVISION

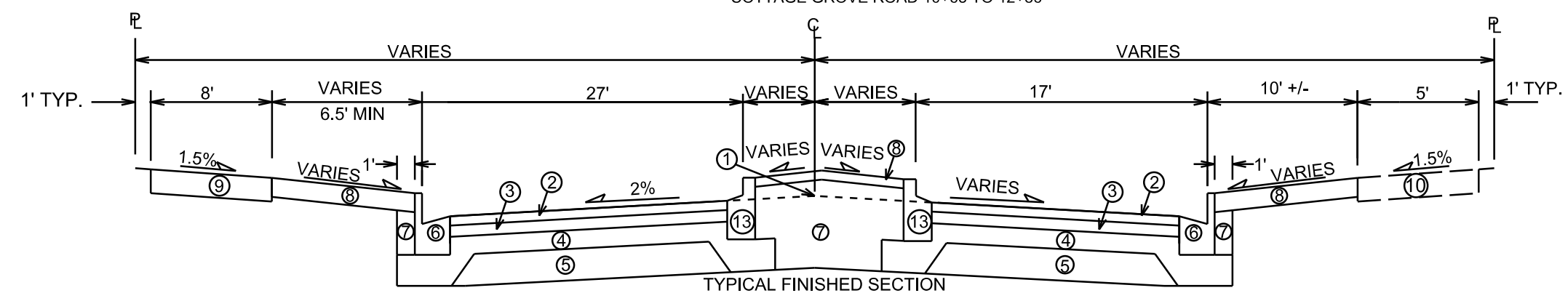
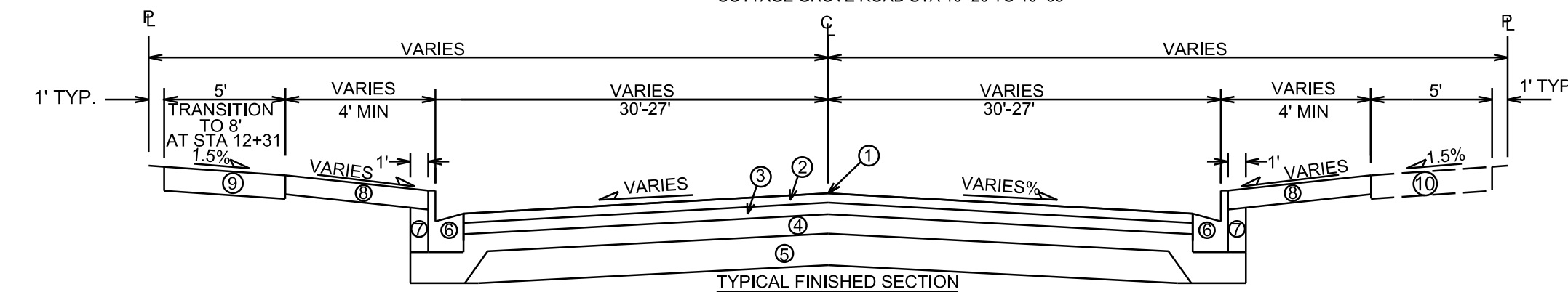
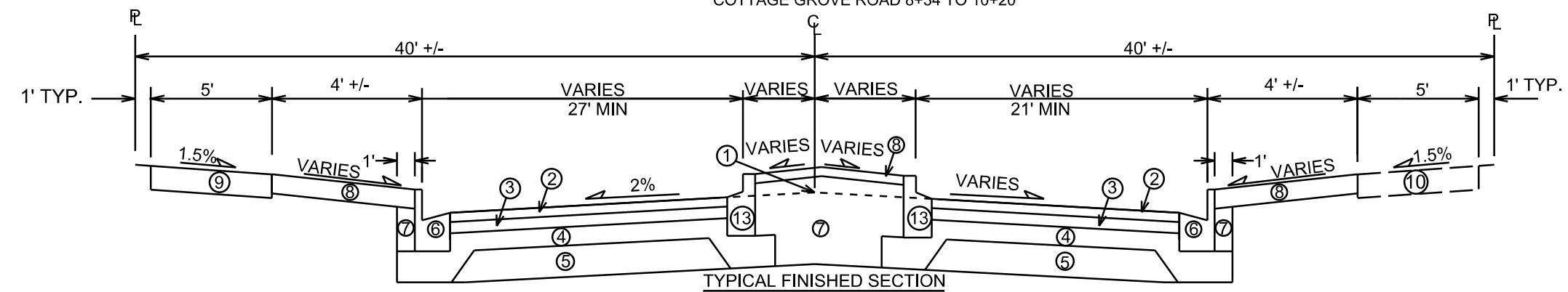
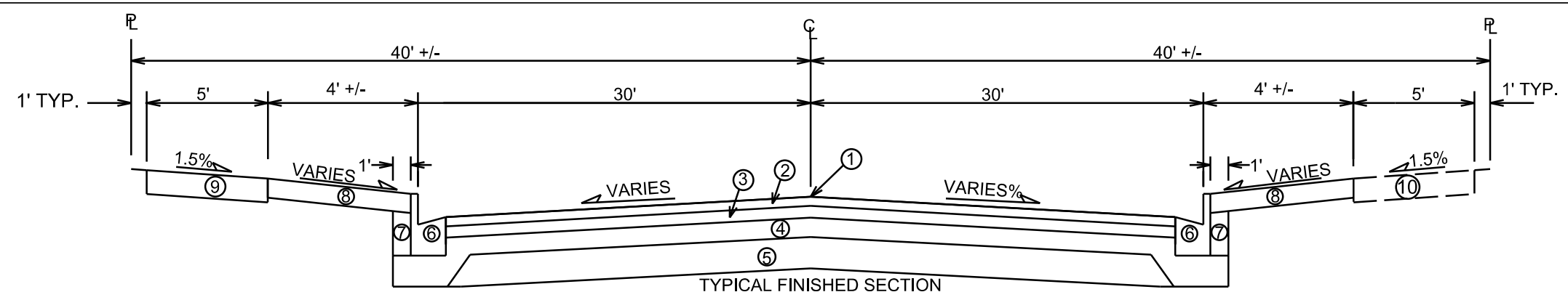

- ① POINT REFERRED TO ON PROFILE
- ② 3.00" BITUMINOUS UPPER LAYER, TYPE E-3, 12.5 mm
- ③ 3.00" BITUMINOUS LOWER LAYER, TYPE E-3, 19 mm
- ④ 8" GRADATION 2 CRUSHED STONE
- ⑤ 8" GRADATION 1 CRUSHED STONE
- ⑥ TYPE 'A' CONCRETE CURB & GUTTER
- ⑦ FILL, INCIDENTAL
- ⑧ 4" TOPSOIL, SEED & MAT
- ⑨ 5" OR 7" CONCRETE SIDEWALK
- ⑩ EXISTING SIDEWALK, SEE PLAN FOR SPOT REPLACE
- ⑪ TYPE 'H' CONCRETE CURB & GUTTER
- ⑫ 7" STAMPED & COLORED CONCRETE
- ⑬ TYPE 'E' CONCRETE CURB & GUTTER

TYPICAL SECTIONS NOT TO SCALE

PLOT SCALE: _____
PLOT NAME: _____
REV. DATE: _____
ORIGINATOR: CITY OF MADISON, STREETS DIVISION

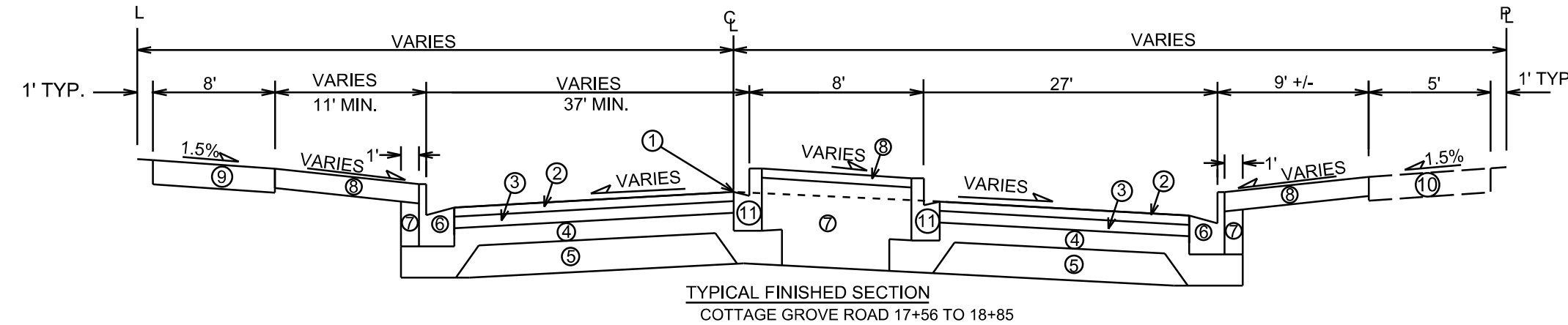
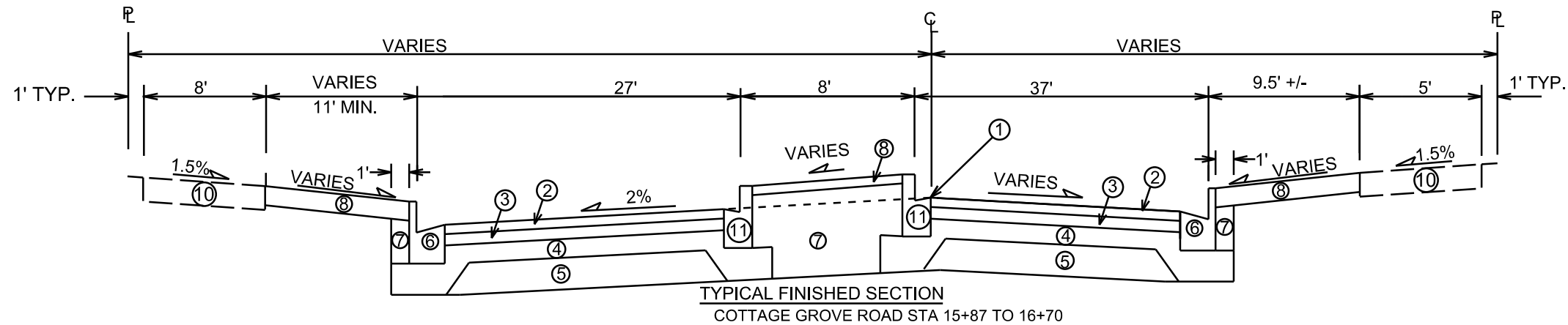
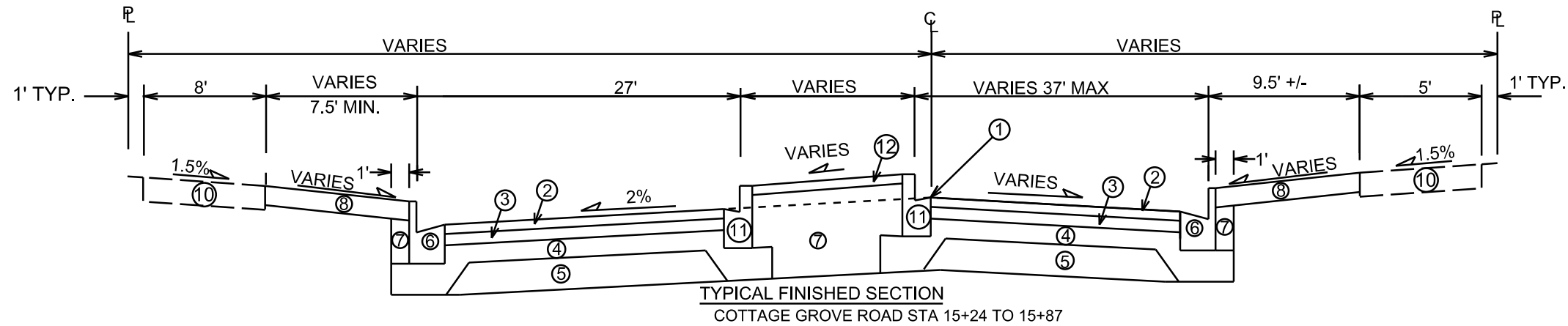
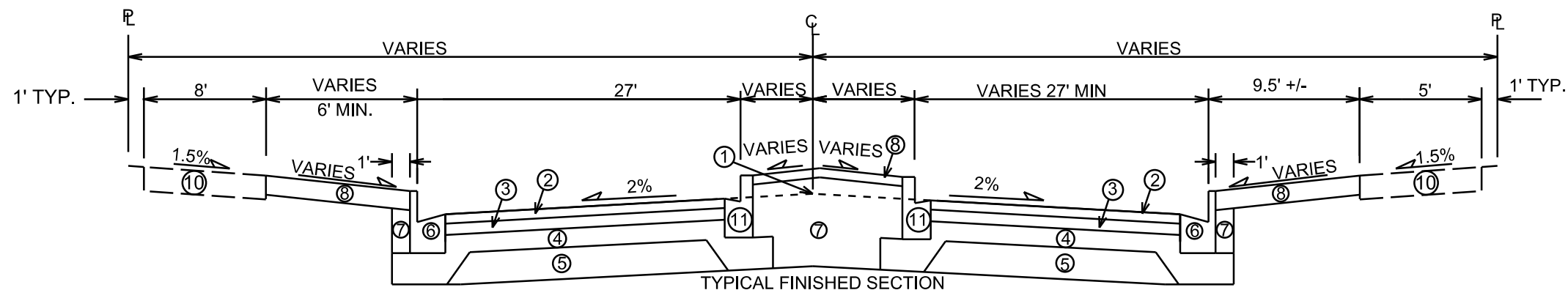

- ① POINT REFERRED TO ON PROFILE
- ② 3.00" BITUMINOUS UPPER LAYER, TYPE E-3, 12.5 mm
- ③ 3.00" BITUMINOUS LOWER LAYER, TYPE E-3, 19 mm
- ④ 8" GRADATION 2 CRUSHED STONE
- ⑤ 8" GRADATION 1 CRUSHED STONE
- ⑥ TYPE 'A' CONCRETE CURB & GUTTER
- ⑦ FILL, INCIDENTAL
- ⑧ 4" TOPSOIL, SEED & MAT
- ⑨ 5" OR 7" CONCRETE SIDEWALK
- ⑩ EXISTING SIDEWALK, SEE PLAN FOR SPOT REPLACE
- ⑪ TYPE 'H' CONCRETE CURB & GUTTER
- ⑫ 7" STAMPED & COLORED CONCRETE
- ⑬ TYPE 'E' CONCRETE CURB & GUTTER

TYPICAL SECTIONS NOT TO SCALE

PLOT SCALE: _____
PLOT NAME: _____
REV. DATE: _____
ORIGINATOR: CITY OF MADISON, STREETS DIVISION

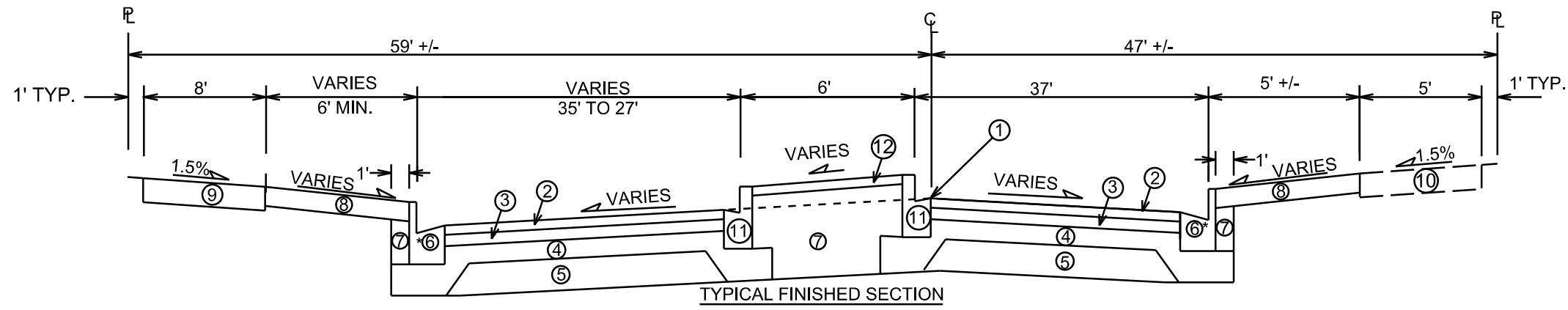
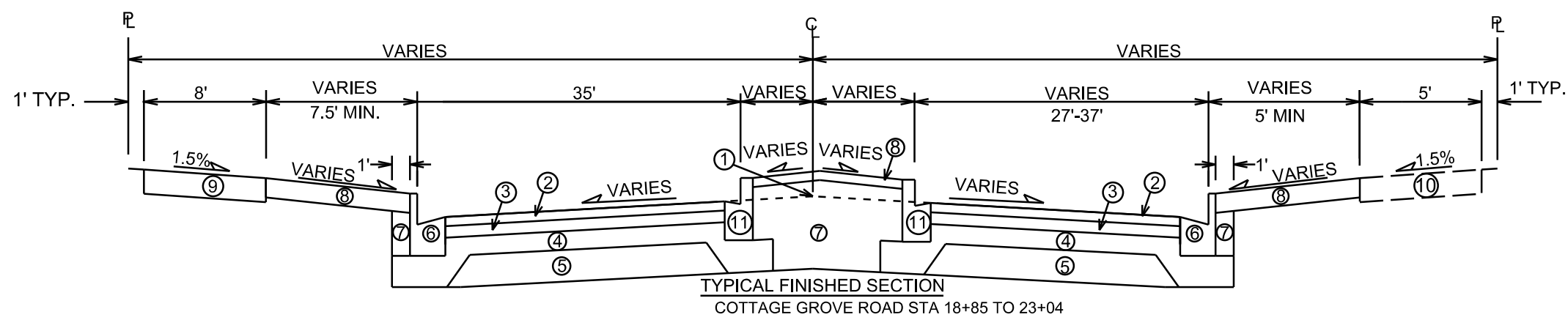

* USE TYPE E CURB NEAR EAST END
MEDIAN - SEE PLAN FOR LOCATIONS

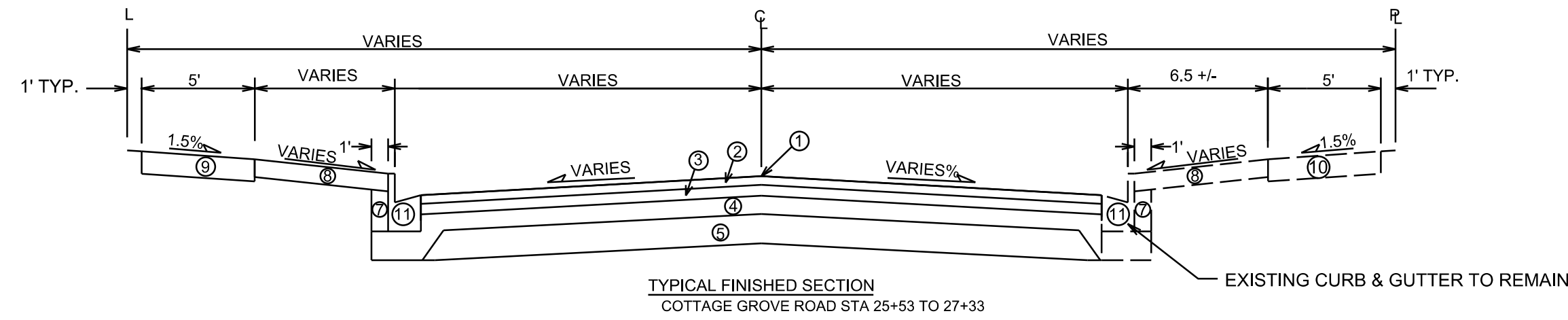

- ① POINT REFERRED TO ON PROFILE
- ② 3.00" BITUMINOUS UPPER LAYER, TYPE E-3, 12.5 mm
- ③ 3.00" BITUMINOUS LOWER LAYER, TYPE E-3, 19 mm
- ④ 8" GRADATION 2 CRUSHED STONE
- ⑤ 8" GRADATION 1 CRUSHED STONE
- ⑥ TYPE 'A' CONCRETE CURB & GUTTER
- ⑦ FILL, INCIDENTAL
- ⑧ 4" TOPSOIL, SEED & MAT
- ⑨ 5" OR 7" CONCRETE SIDEWALK
- ⑩ EXISTING SIDEWALK, SEE PLAN FOR SPOT REPLACE
- ⑪ TYPE 'H' CONCRETE CURB & GUTTER
- ⑫ 7" STAMPED & COLORED CONCRETE
- ⑬ TYPE 'E' CONCRETE CURB & GUTTER

TYPICAL SECTIONS NOT TO SCALE

PLOT SCALE: _____
PLOT NAME: _____
REV. DATE: _____
ORIGINATOR: CITY OF MADISON, STREETS DIVISION

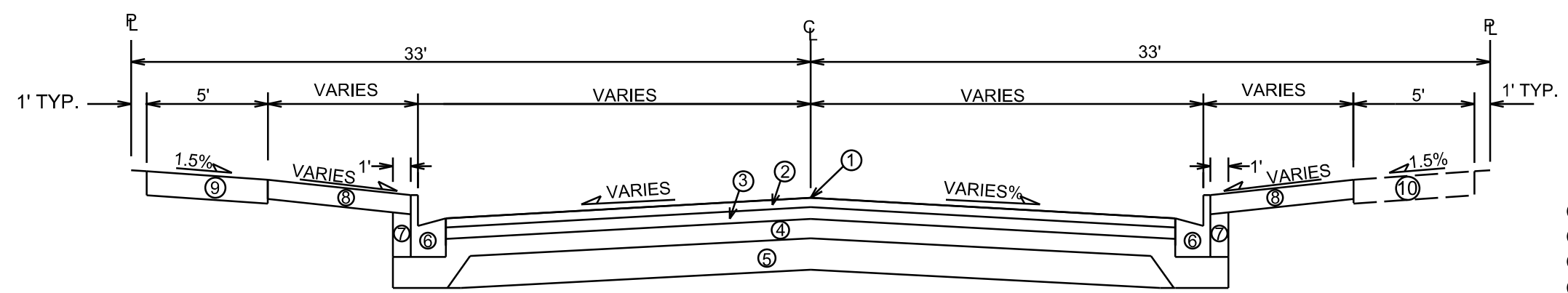

TYPICAL FINISHED SECTION
DEMPSEY ROAD STA 50+36 TO 50+90

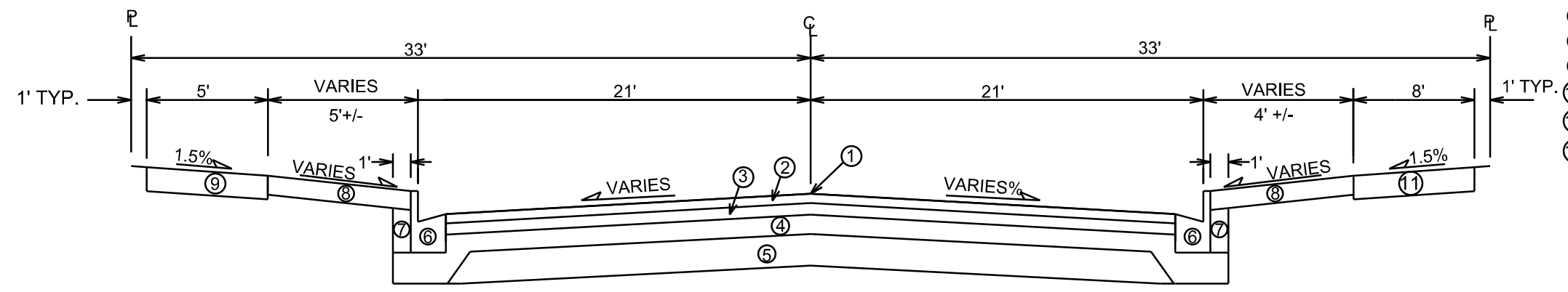

TYPICAL FINISHED SECTION
DEMPSEY ROAD STA 50+90 TO 51+28

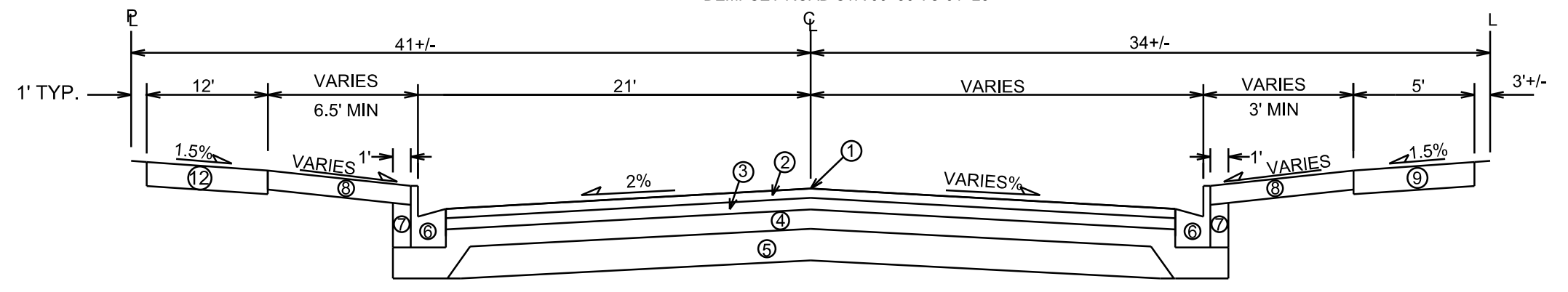

TYPICAL FINISHED SECTION
DEMPSEY ROAD STA 52+44 TO 53+53

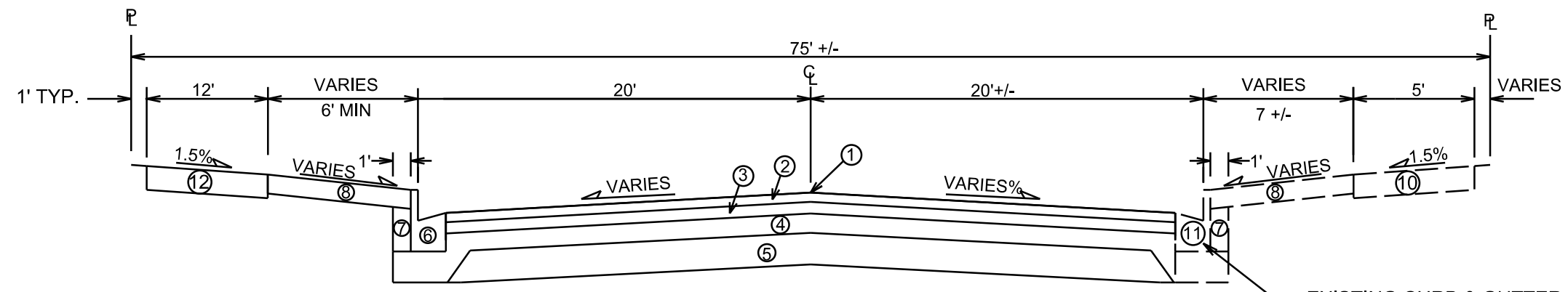

TYPICAL FINISHED SECTION
DEMPSEY ROAD STA 54+25 TO 57+63

- ① POINT REFERRED TO ON PROFILE
- ② 2.00" BITUMINOUS UPPER LAYER, TYPE E-3, 12.5 mm
- ③ 3.25" BITUMINOUS LOWER LAYER, TYPE E-3, 19 mm
- ④ 4" GRADATION 2 CRUSHED STONE
- ⑤ 6" GRADATION 1 CRUSHED STONE
- ⑥ TYPE 'A' CONCRETE CURB & GUTTER
- ⑦ FILL, INCIDENTAL
- ⑧ 4" TOPSOIL, SEED & MAT
- ⑨ 5" OR 7" CONCRETE SIDEWALK
- ⑩ EXISTING SIDEWALK, SEE PLAN FOR SPOT REPLACE
- ⑪ 7" WALK/BIKE, SAW TRANSVERSE JOINTS
- ⑫ 7" WALK/BIKE 12X12 SQUARES, SAW TRANSVERSE JOINTS

TYPICAL SECTIONS NOT TO SCALE

EXISTING CURB & GUTTER TO REMAIN - SEE PLAN FOR REPAIR LOCATIONS

PLOT SCALE: _____
PLOT NAME: _____
REV. DATE: _____
ORIGINATOR: CITY OF MADISON, STREETS DIVISION

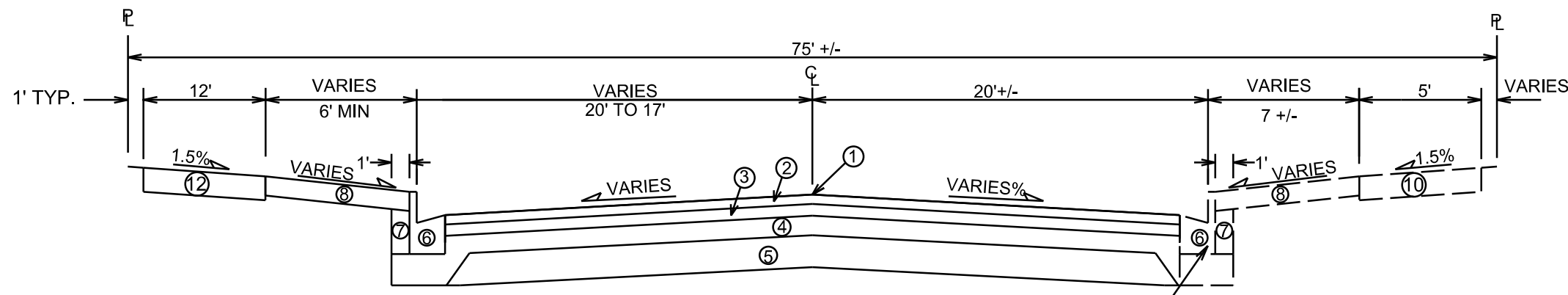

TYPICAL FINISHED SECTION
DEMPSEY ROAD STA 57+63 TO 59+44

EXISTING CURB & GUTTER TO REMAIN
SEE PLAN FOR REPAIR LOCATIONS

- ① POINT REFERRED TO ON PROFILE
- ② 2.00" BITUMINOUS UPPER LAYER, TYPE E-3, 12.5 mm
- ③ 3.25" BITUMINOUS LOWER LAYER, TYPE E-3, 19 mm
- ④ 4" GRADATION 2 CRUSHED STONE
- ⑤ 6" GRADATION 1 CRUSHED STONE
- ⑥ TYPE 'A' CONCRETE CURB & GUTTER
- ⑦ FILL, INCIDENTAL
- ⑧ 4" TOPSOIL, SEED & MAT
- ⑨ 5" OR 7" CONCRETE SIDEWALK
- ⑩ EXISTING SIDEWALK, SEE PLAN FOR SPOT REPLACE
- ⑪ 7" WALK/BIKE, SAW TRANSVERSE JOINTS
- ⑫ 7" WALK/BIKE 12X12 SQUARES, SAW TRANSVERSE JOINTS

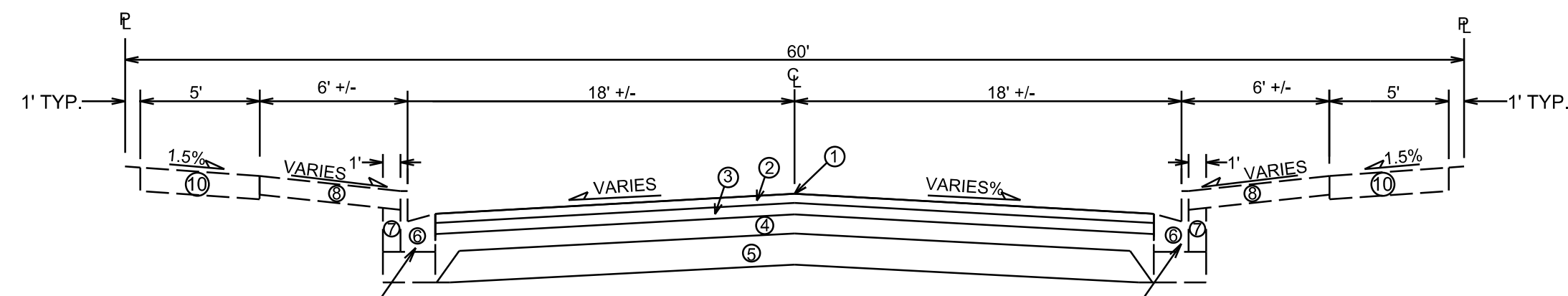

TYPICAL FINISHED SECTION
DEMPSEY ROAD STA 60+25 TO 69+25

EXISTING CURB & GUTTER TO REMAIN
SEE PLAN FOR REPAIR LOCATIONS

EXISTING CURB & GUTTER TO REMAIN
SEE PLAN FOR REPAIR LOCATIONS

TYPICAL SECTIONS NOT TO SCALE

PLOT SCALE: _____
PLOT NAME: _____
REV. DATE: _____

ORIGINATOR: CITY OF MADISON, STREETS DIVISION

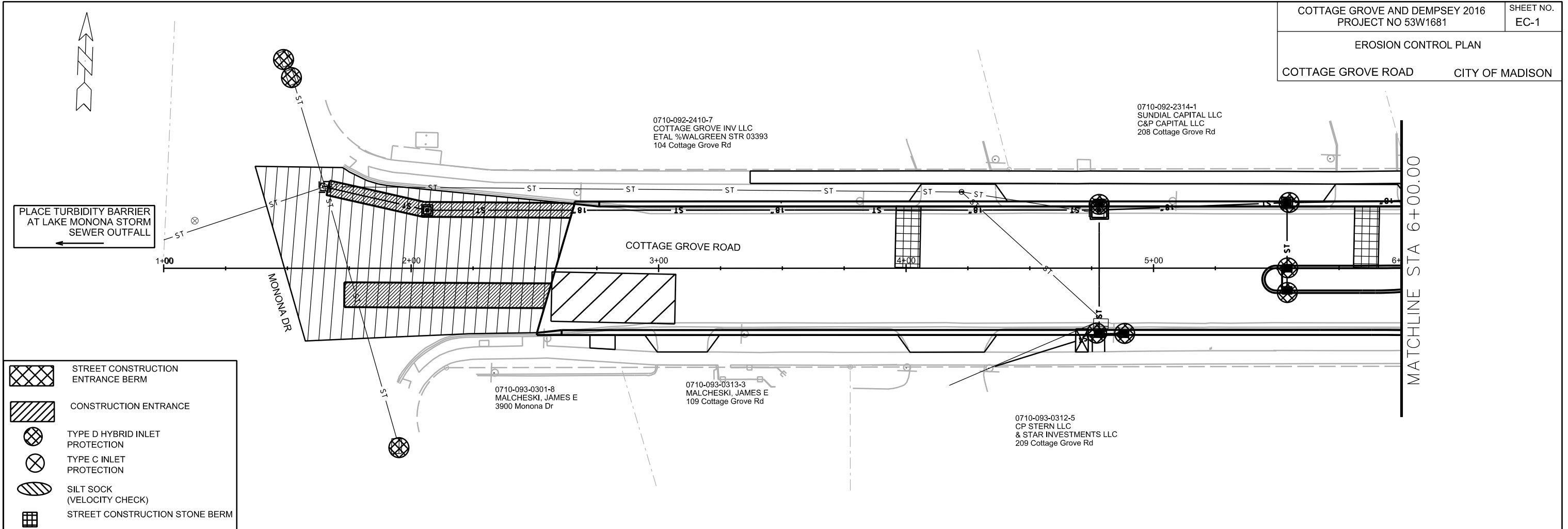

- STREET CONSTRUCTION ENTRANCE BERM
- CONSTRUCTION ENTRANCE
- TYPE D HYBRID INLET PROTECTION
- TYPE C INLET PROTECTION
- SILT SOCK (VELOCITY CHECK)
- STREET CONSTRUCTION STONE BERM

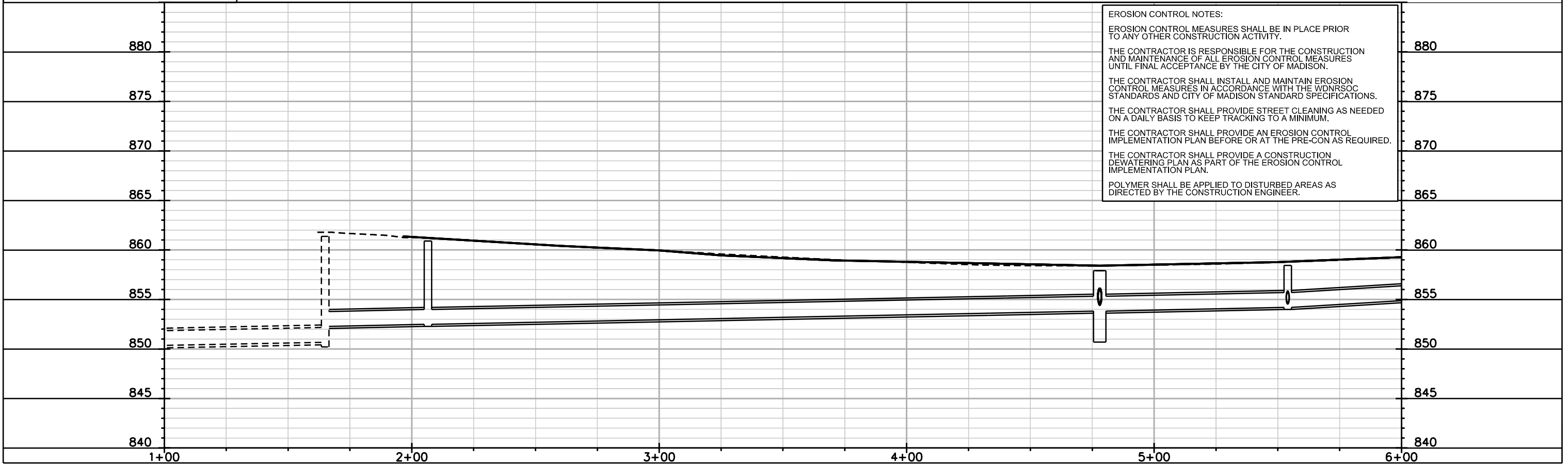

PLOT SCALE: _____

PLOT NAME: _____

REV. DATE: _____

ORIGINATOR: CITY OF MADISON, STREETS DIVISION

0710-092-1727-7
926 ROYSTER OAKS DRIVE
RDC DEVELOPMENT LLC

0710-092-1728-5
MADISON GAS & ELECTRIC CO
310 Cottage Grove Rd

0710-092-1725-1
MASON REAL ESTATE
HOLDINGS LLC
300 Cottage Grove Rd

0710-093-0307-6
VFW POST 7591
DONALD & GALEN DAY
301 Cottage Grove Rd

0710-093-0310-9
KREHL, ESTHER
3902 Drexel Ave

0710-093-0208-6
RIPPLE FAMILY LIMITED
PARTNERSHIP
401 Cottage Grove Rd

0710-093-0207-8
NOTARGIOVANNI, PATRICK &
T MARGARET NOTARGIOVANNI
405 Cottage Grove Rd

0710-093-0206-0
MARON I LLC
409 Cottage Grove Rd

MATCHLINE STA 11+00.00

MATCHLINE STA 16+00.00

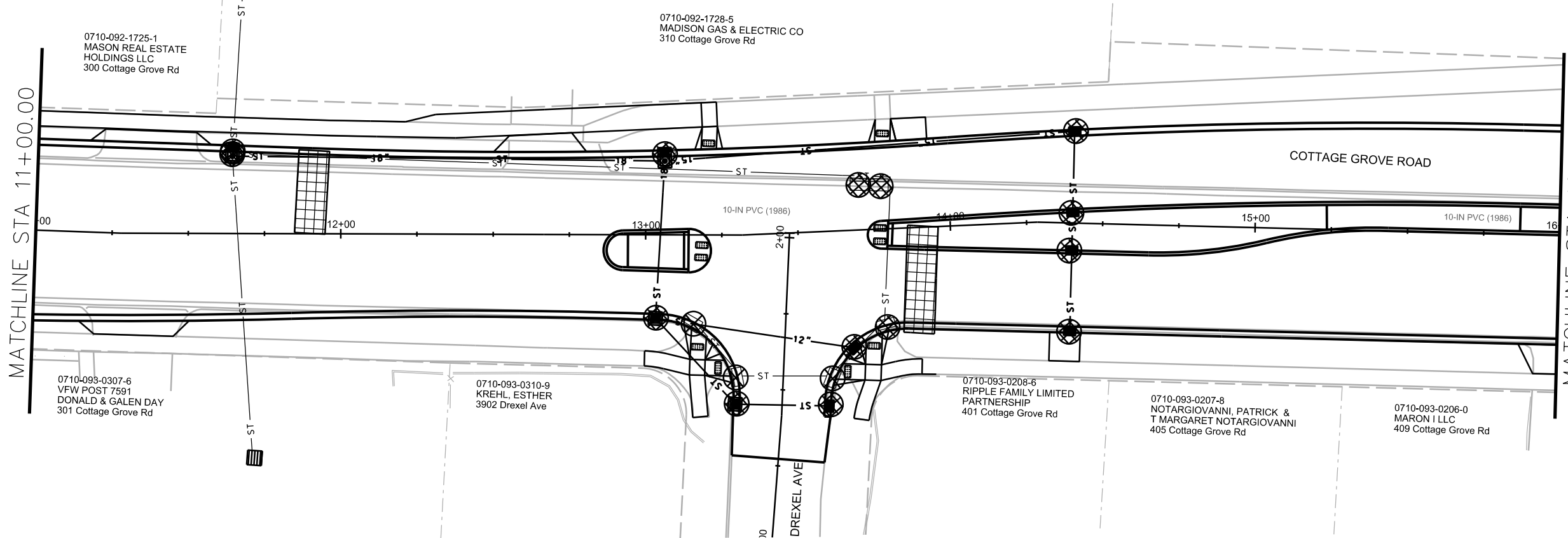

EROSION CONTROL NOTES:
EROSION CONTROL MEASURES SHALL BE IN PLACE PRIOR TO ANY OTHER CONSTRUCTION ACTIVITY.

885 THE CONTRACTOR IS RESPONSIBLE FOR THE CONSTRUCTION AND MAINTENANCE OF ALL EROSION CONTROL MEASURES UNTIL FINAL ACCEPTANCE BY THE CITY OF MADISON.







880 THE CONTRACTOR SHALL INSTALL AND MAINTAIN EROSION CONTROL MEASURES IN ACCORDANCE WITH THE WDNR SOC STANDARDS AND CITY OF MADISON STANDARD SPECIFICATIONS.

875 THE CONTRACTOR SHALL PROVIDE STREET CLEANING AS NEEDED ON A DAILY BASIS TO KEEP TRACKING TO A MINIMUM.

870 THE CONTRACTOR SHALL PROVIDE AN EROSION CONTROL IMPLEMENTATION PLAN BEFORE OR AT THE PRE-CON AS REQUIRED.

THE CONTRACTOR SHALL PROVIDE A CONSTRUCTION DEWATERING PLAN AS PART OF THE EROSION CONTROL IMPLEMENTATION PLAN.

POLYMER SHALL BE APPLIED TO DISTURBED AREAS AS DIRECTED BY THE CONSTRUCTION ENGINEER.

-  STREET CONSTRUCTION ENTRANCE BERM
-  CONSTRUCTION ENTRANCE
-  TYPE D HYBRID INLET PROTECTION
-  TYPE C INLET PROTECTION
-  SILT SOCK (VELOCITY CHECK)
-  STREET CONSTRUCTION STONE BERM

885
880
875
870
865
860
855
850
845

885
880
875
870
865
860
855
850
845

11+00 12+00 13+00 14+00 15+00 16+00

PLOT SCALE: _____

PLOT NAME: _____

REV. DATE: _____

ORIGINATOR: CITY OF MADISON, STREETS DIVISION

0710-092-1727-7
926 ROYSTER OAKS DRIVE
RDC DEVELOPMENT LLC

0710-092-2704-4
RDC DEVELOPMENT LLC
502 Cottage Grove Rd

0710-092-2703-6
RDC DEVELOPMENT LLC
516 Cottage Grove Rd

0710-093-0205-2
MEIER, BRIAN
MEKEL WIEDERHOLT MEIER
3901 Maher Ave

0710-093-0119-5
SMITH, CHARLENE
3902 Maher Ave

0710-093-0118-7
BOWERS, KENNETH & JANE
505 Cottage Grove Rd

0710-093-0117-9
KT INVESTMENTS LLC
ATTN KEN BOWERS
509 Cottage Grove Rd

0710-093-0116-1
ROEMING, STEPHANIE F
513 Cottage Grove Rd

0710-093-0115-3
ROEMING, STEPHANIE F
515 Cottage Grove Rd

MATCHLINE STA 16+00.00

MATCHLINE STA 21+00.00

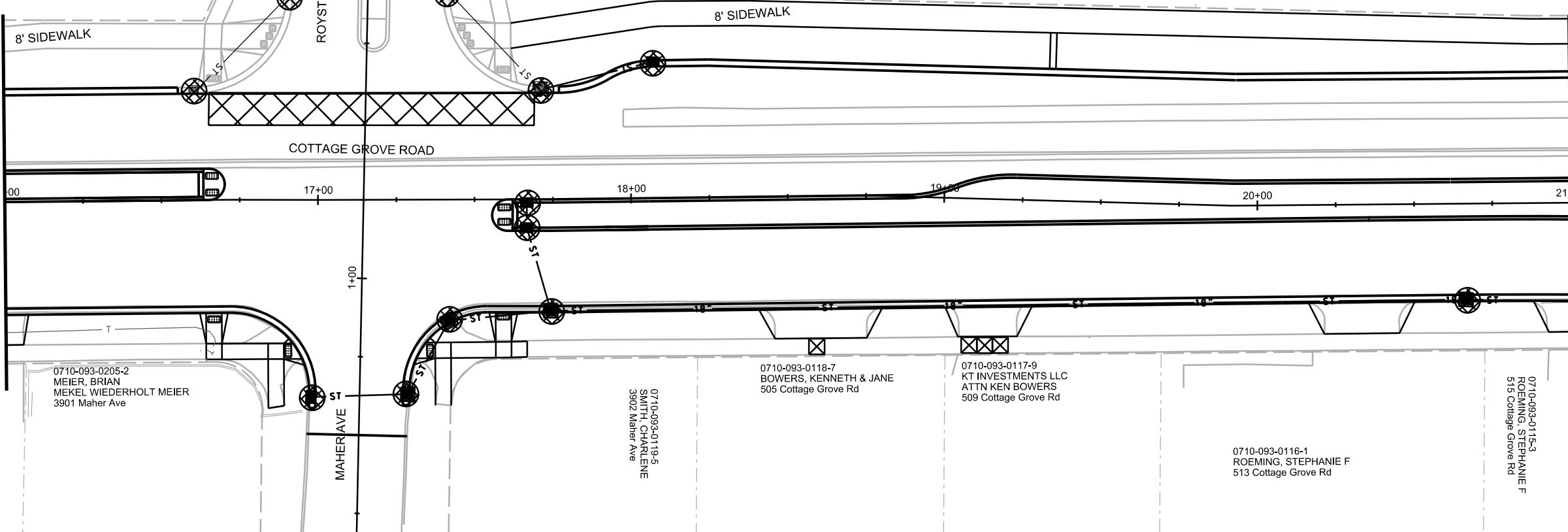

EROSION CONTROL NOTES:

EROSION CONTROL MEASURES SHALL BE IN PLACE PRIOR TO ANY OTHER CONSTRUCTION ACTIVITY.

885 THE CONTRACTOR IS RESPONSIBLE FOR THE CONSTRUCTION AND MAINTENANCE OF ALL EROSION CONTROL MEASURES UNTIL FINAL ACCEPTANCE BY THE CITY OF MADISON.

880 THE CONTRACTOR SHALL INSTALL AND MAINTAIN EROSION CONTROL MEASURES IN ACCORDANCE WITH THE WDNR SOC STANDARDS AND CITY OF MADISON STANDARD SPECIFICATIONS.

875 THE CONTRACTOR SHALL PROVIDE STREET CLEANING AS NEEDED ON A DAILY BASIS TO KEEP TRACKING TO A MINIMUM.

THE CONTRACTOR SHALL PROVIDE AN EROSION CONTROL IMPLEMENTATION PLAN BEFORE OR AT THE PRE-CON AS REQUIRED.

870 THE CONTRACTOR SHALL PROVIDE A CONSTRUCTION DEWATERING PLAN AS PART OF THE EROSION CONTROL IMPLEMENTATION PLAN.

POLYMER SHALL BE APPLIED TO DISTURBED AREAS AS DIRECTED BY THE CONSTRUCTION ENGINEER.

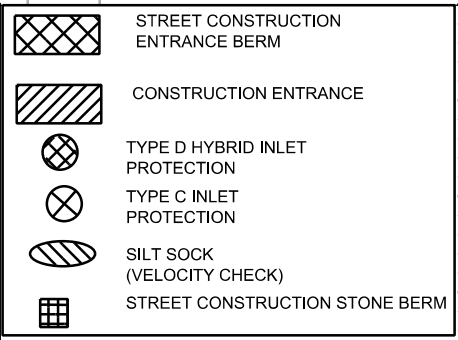

885

880

875

870

865

860

855

850

845

885

880

875

870

865

860

855

850

845

16+00 17+00 18+00 19+00 20+00 21+00

PLOT SCALE: _____

PLOT NAME: _____

REV. DATE: _____

ORIGINATOR: CITY OF MADISON, STREETS DIVISION

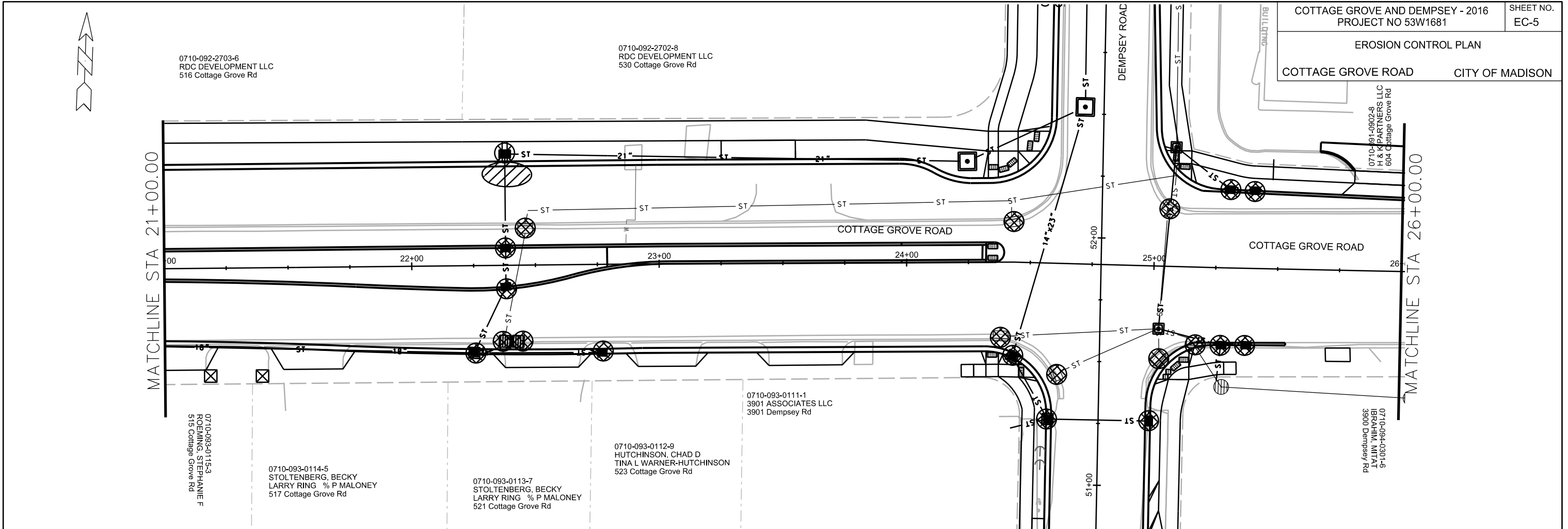

EROSION CONTROL NOTES:

EROSION CONTROL MEASURES SHALL BE IN PLACE PRIOR TO ANY OTHER CONSTRUCTION ACTIVITY.

THE CONTRACTOR IS RESPONSIBLE FOR THE CONSTRUCTION AND MAINTENANCE OF ALL EROSION CONTROL MEASURES UNTIL FINAL ACCEPTANCE BY THE CITY OF MADISON.

THE CONTRACTOR SHALL INSTALL AND MAINTAIN EROSION CONTROL MEASURES IN ACCORDANCE WITH THE WDNR SOC STANDARDS AND CITY OF MADISON STANDARD SPECIFICATIONS.

THE CONTRACTOR SHALL PROVIDE STREET CLEANING AS NEEDED ON A DAILY BASIS TO KEEP TRACKING TO A MINIMUM.

THE CONTRACTOR SHALL PROVIDE AN EROSION CONTROL IMPLEMENTATION PLAN BEFORE OR AT THE PRE-CON AS REQUIRED.

THE CONTRACTOR SHALL PROVIDE A CONSTRUCTION DEWATERING PLAN AS PART OF THE EROSION CONTROL IMPLEMENTATION PLAN.

POLYMER SHALL BE APPLIED TO DISTURBED AREAS AS DIRECTED BY THE CONSTRUCTION ENGINEER.

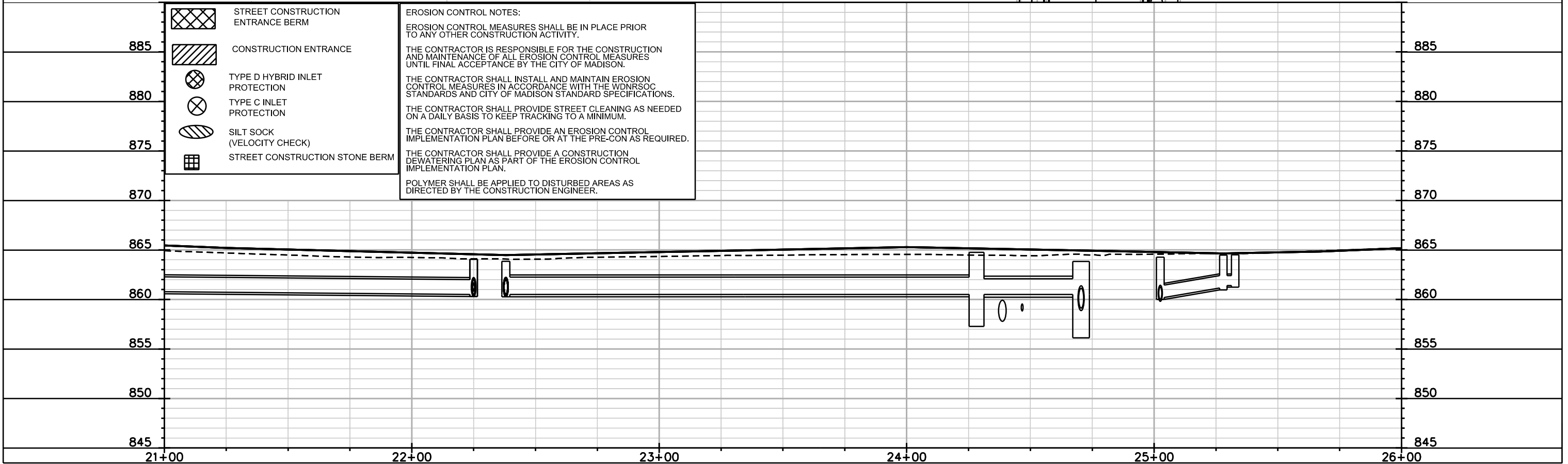

PLOT SCALE: _____

PLOT NAME: _____

REV. DATE: _____

ORIGINATOR: CITY OF MADISON, STREETS DIVISION

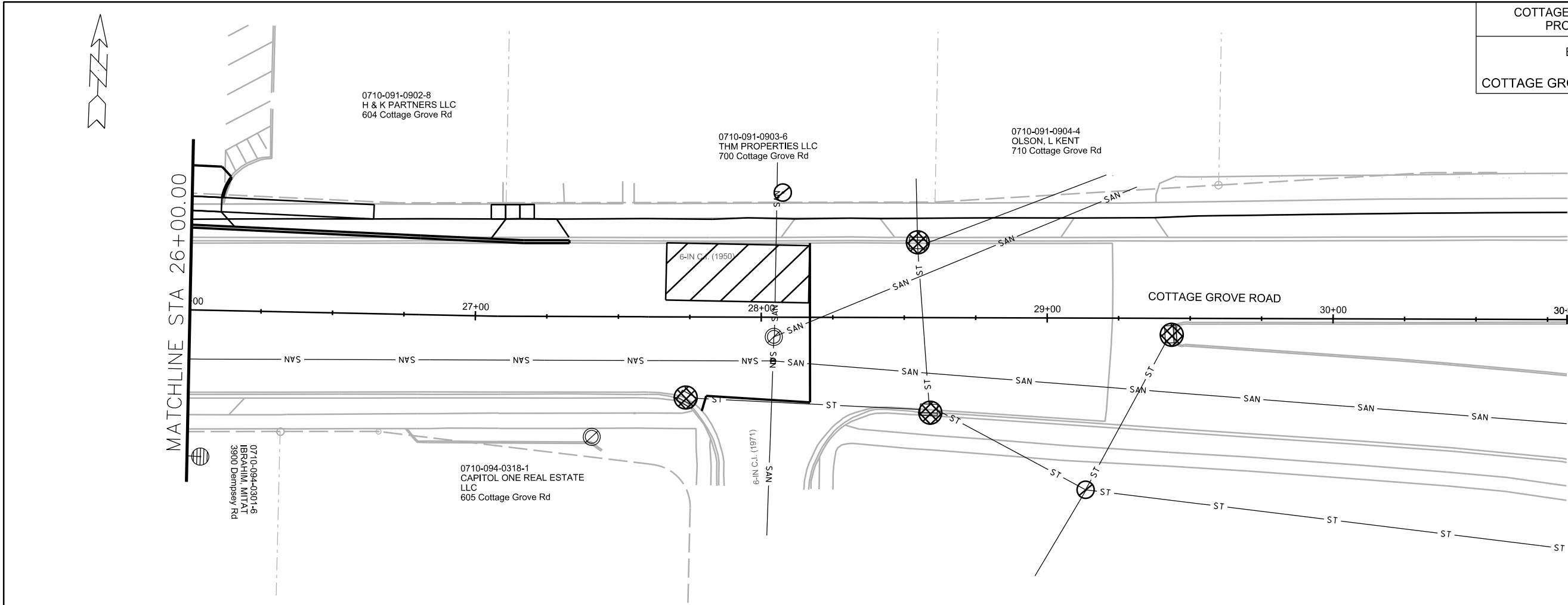

EROSION CONTROL NOTES:

EROSION CONTROL MEASURES SHALL BE IN PLACE PRIOR TO ANY OTHER CONSTRUCTION ACTIVITY.

THE CONTRACTOR IS RESPONSIBLE FOR THE CONSTRUCTION AND MAINTENANCE OF ALL EROSION CONTROL MEASURES UNTIL FINAL ACCEPTANCE BY THE CITY OF MADISON.







THE CONTRACTOR SHALL INSTALL AND MAINTAIN EROSION CONTROL MEASURES IN ACCORDANCE WITH THE WDNR SOC STANDARDS AND CITY OF MADISON STANDARD SPECIFICATIONS.

THE CONTRACTOR SHALL PROVIDE STREET CLEANING AS NEEDED ON A DAILY BASIS TO KEEP TRACKING TO A MINIMUM.

THE CONTRACTOR SHALL PROVIDE AN EROSION CONTROL IMPLEMENTATION PLAN BEFORE OR AT THE PRE-CON AS REQUIRED.

THE CONTRACTOR SHALL PROVIDE A CONSTRUCTION DEWATERING PLAN AS PART OF THE EROSION CONTROL IMPLEMENTATION PLAN.

POLYMER SHALL BE APPLIED TO DISTURBED AREAS AS DIRECTED BY THE CONSTRUCTION ENGINEER.

-  STREET CONSTRUCTION ENTRANCE BERM
-  CONSTRUCTION ENTRANCE
-  TYPE D HYBRID INLET PROTECTION
-  TYPE C INLET PROTECTION
-  SILT SOCK (VELOCITY CHECK)
-  STREET CONSTRUCTION STONE BERM

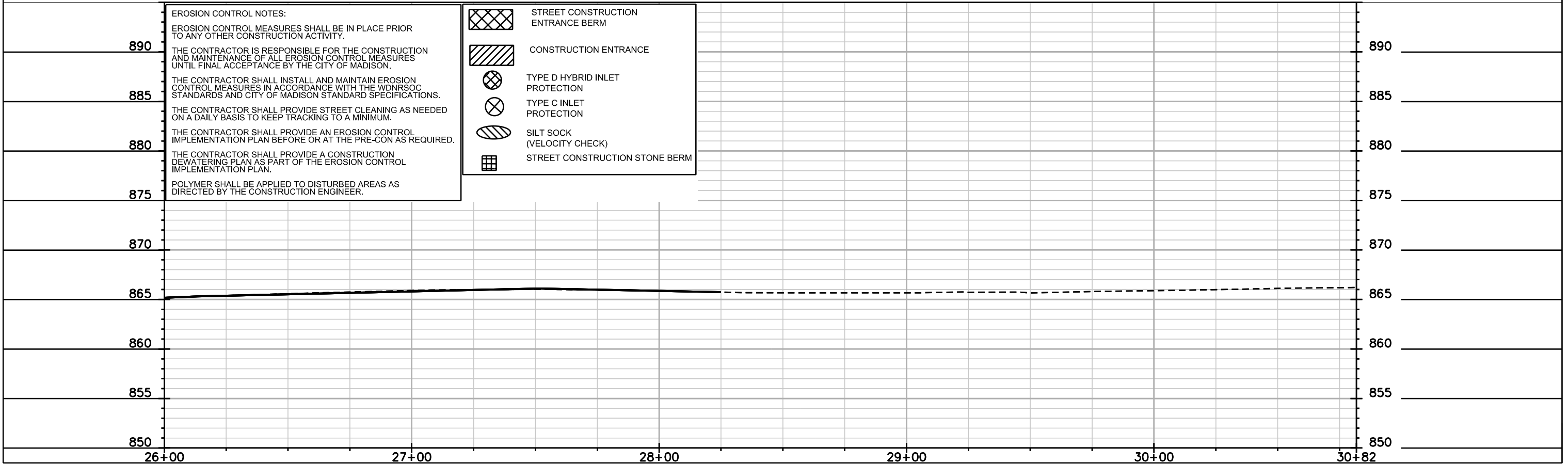





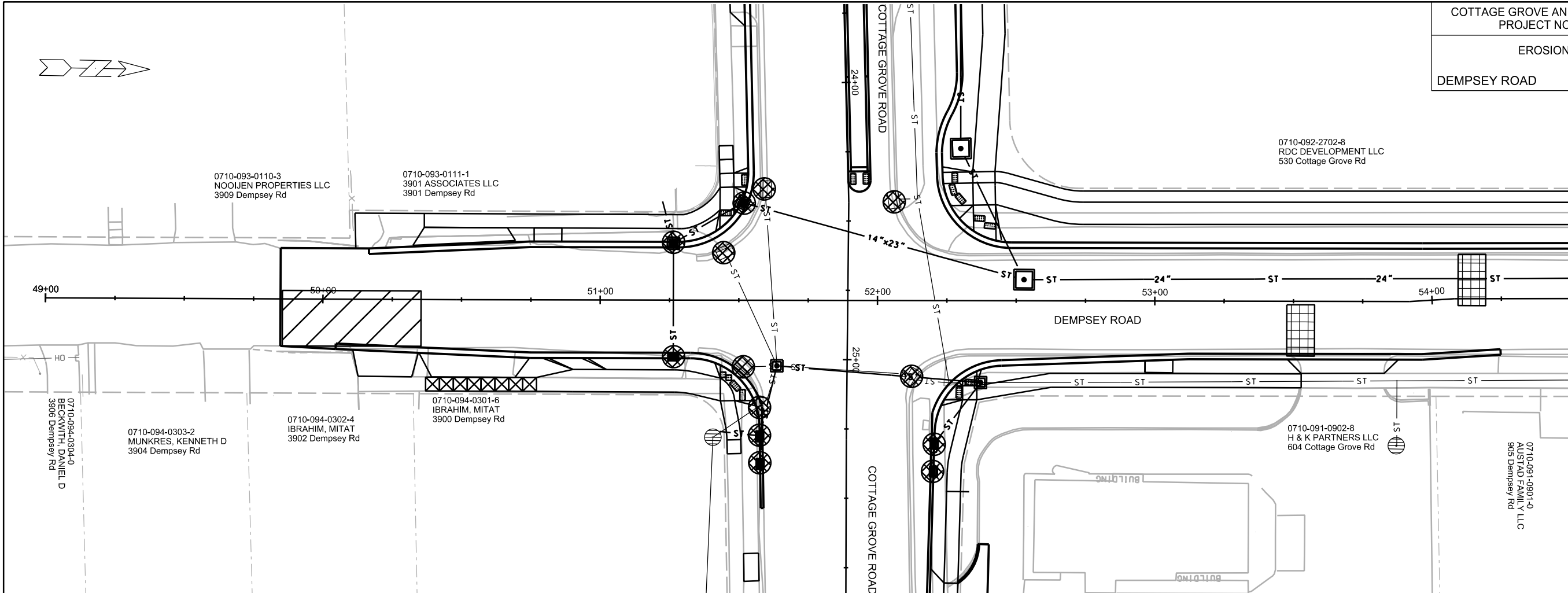

PLOT SCALE: _____

PLOT NAME: _____

REV. DATE: _____

ORIGINATOR: CITY OF MADISON, STREETS DIVISION



-  STREET CONSTRUCTION ENTRANCE BERM
-  CONSTRUCTION ENTRANCE
-  TYPE D HYBRID INLET PROTECTION
-  TYPE C INLET PROTECTION
-  SILT SOCK (VELOCITY CHECK)
-  STREET CONSTRUCTION STONE BERM

EROSION CONTROL NOTES:

EROSION CONTROL MEASURES SHALL BE IN PLACE PRIOR TO ANY OTHER CONSTRUCTION ACTIVITY.

THE CONTRACTOR IS RESPONSIBLE FOR THE CONSTRUCTION AND MAINTENANCE OF ALL EROSION CONTROL MEASURES UNTIL FINAL ACCEPTANCE BY THE CITY OF MADISON.

THE CONTRACTOR SHALL INSTALL AND MAINTAIN EROSION CONTROL MEASURES IN ACCORDANCE WITH THE WDMRSOC STANDARDS AND CITY OF MADISON STANDARD SPECIFICATIONS.

THE CONTRACTOR SHALL PROVIDE STREET CLEANING AS NEEDED ON A DAILY BASIS TO KEEP TRACKING TO A MINIMUM.

THE CONTRACTOR SHALL PROVIDE AN EROSION CONTROL IMPLEMENTATION PLAN BEFORE OR AT THE PRE-CON AS REQUIRED.

THE CONTRACTOR SHALL PROVIDE A CONSTRUCTION DEWATERING PLAN AS PART OF THE EROSION CONTROL IMPLEMENTATION PLAN.

POLYMER SHALL BE APPLIED TO DISTURBED AREAS AS DIRECTED BY THE CONSTRUCTION ENGINEER.

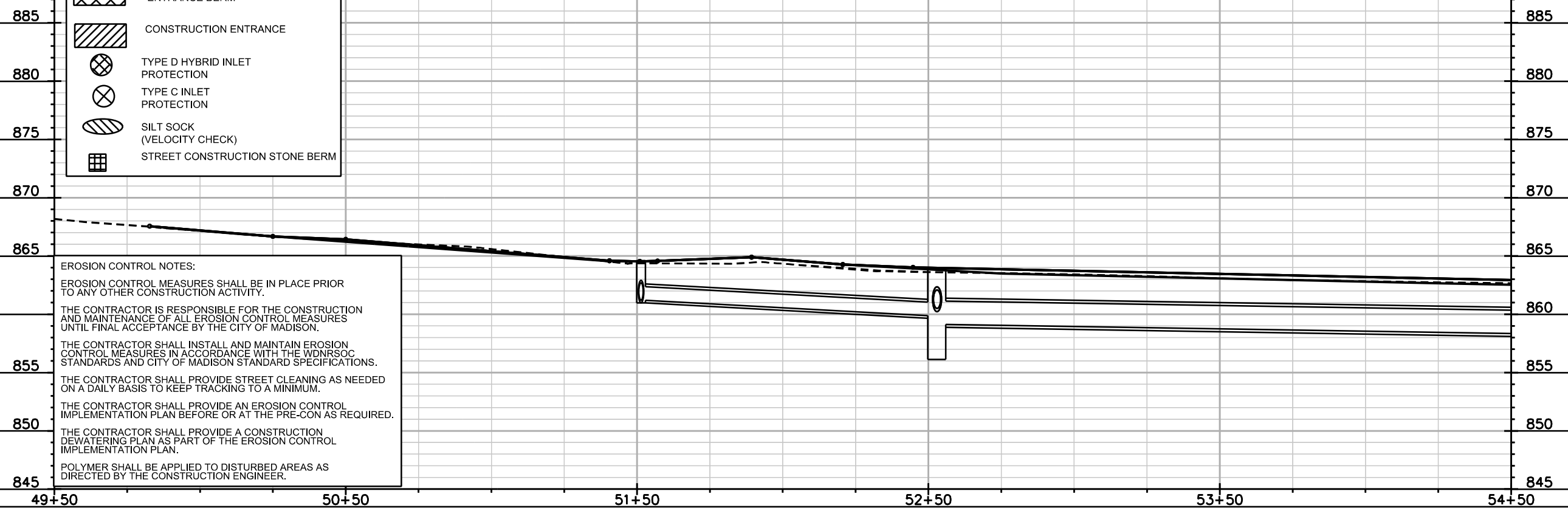

PLOT SCALE: _____

PLOT NAME: _____

REV. DATE: _____

ORIGINATOR: CITY OF MADISON, STREETS DIVISION

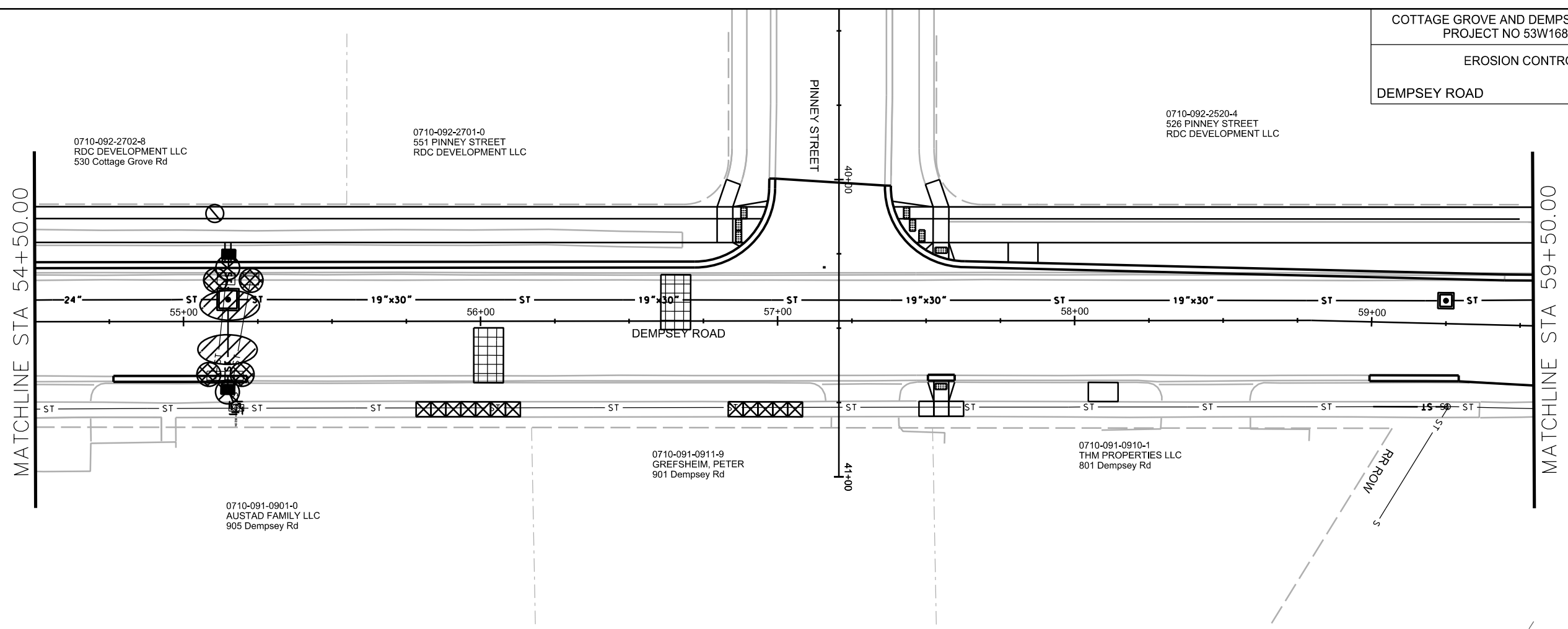

EROSION CONTROL NOTES:

885 EROSION CONTROL MEASURES SHALL BE IN PLACE PRIOR TO ANY OTHER CONSTRUCTION ACTIVITY.

880 THE CONTRACTOR IS RESPONSIBLE FOR THE CONSTRUCTION AND MAINTENANCE OF ALL EROSION CONTROL MEASURES UNTIL FINAL ACCEPTANCE BY THE CITY OF MADISON.

875 THE CONTRACTOR SHALL INSTALL AND MAINTAIN EROSION CONTROL MEASURES IN ACCORDANCE WITH THE WDNR SOC STANDARDS AND CITY OF MADISON STANDARD SPECIFICATIONS.

870 THE CONTRACTOR SHALL PROVIDE STREET CLEANING AS NEEDED ON A DAILY BASIS TO KEEP TRACKING TO A MINIMUM.

THE CONTRACTOR SHALL PROVIDE AN EROSION CONTROL IMPLEMENTATION PLAN BEFORE OR AT THE PRE-CON AS REQUIRED.

THE CONTRACTOR SHALL PROVIDE A CONSTRUCTION DEWATERING PLAN AS PART OF THE EROSION CONTROL IMPLEMENTATION PLAN.

POLYMER SHALL BE APPLIED TO DISTURBED AREAS AS DIRECTED BY THE CONSTRUCTION ENGINEER.

| | |
|--|-----------------------------------|
| | STREET CONSTRUCTION ENTRANCE BERM |
| | CONSTRUCTION ENTRANCE |
| | TYPE D HYBRID INLET PROTECTION |
| | TYPE C INLET PROTECTION |
| | SILT SOCK (VELOCITY CHECK) |
| | STREET CONSTRUCTION STONE BERM |

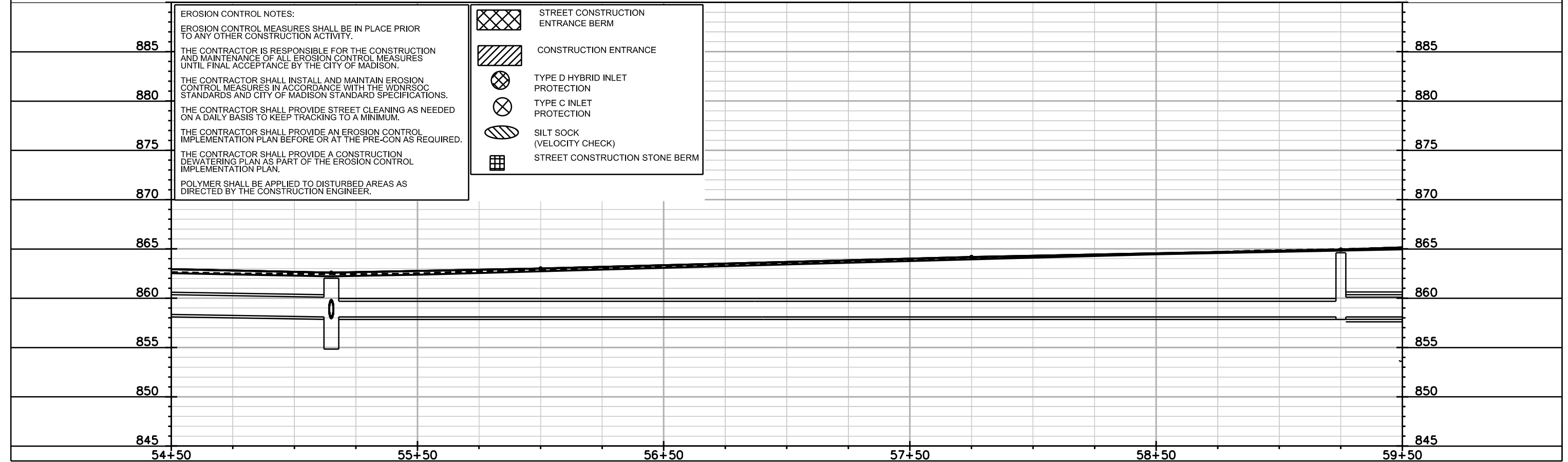

PLOT SCALE: _____

PLOT NAME: _____

REV. DATE: _____





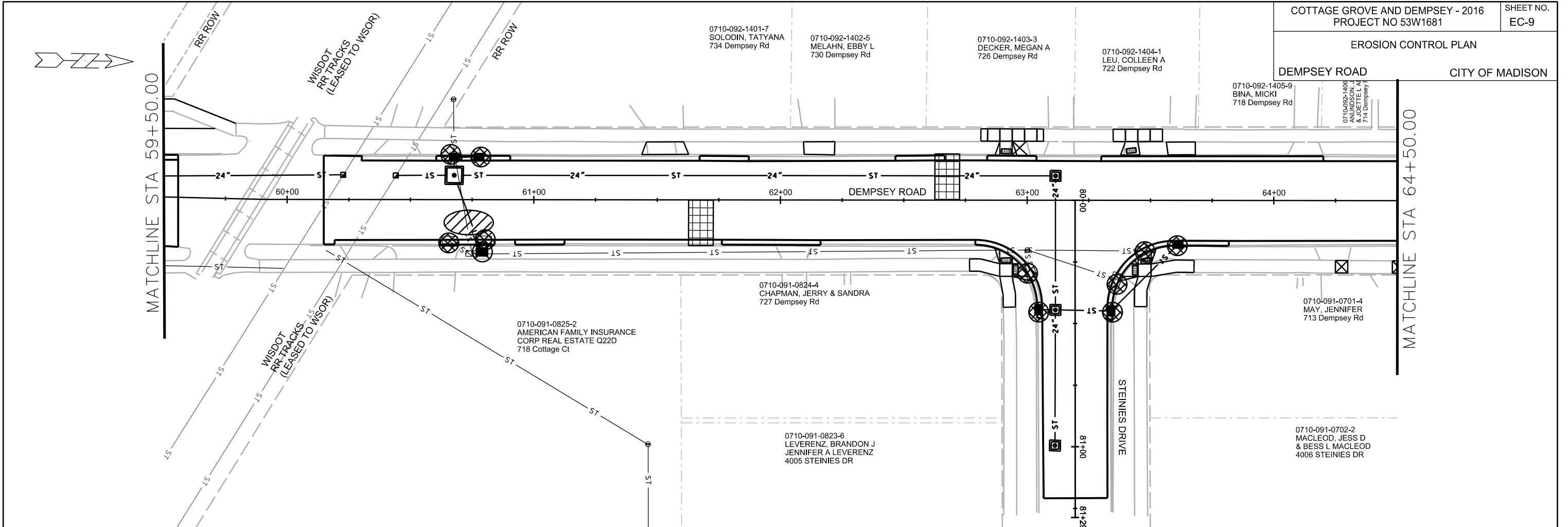

ORIGINATOR: CITY OF MADISON, STREETS DIVISION

EROSION CONTROL PLAN

DEMPSEY ROAD CITY OF MADISON



EROSION CONTROL NOTES:
 EROSION CONTROL MEASURES SHALL BE IN PLACE PRIOR TO ANY OTHER CONSTRUCTION ACTIVITY.
 THE CONTRACTOR IS RESPONSIBLE FOR THE CONSTRUCTION AND MAINTENANCE OF ALL EROSION CONTROL MEASURES UNTIL FINAL ACCEPTANCE BY THE CITY OF MADISON.
 THE CONTRACTOR SHALL INSTALL AND MAINTAIN EROSION CONTROL MEASURES IN ACCORDANCE WITH THE WDNR SOC STANDARDS AND CITY OF MADISON STANDARD SPECIFICATIONS.
 THE CONTRACTOR SHALL PROVIDE STREET CLEANING AS NEEDED ON A DAILY BASIS TO KEEP TRACKING TO A MINIMUM.
 THE CONTRACTOR SHALL PROVIDE AN EROSION CONTROL IMPLEMENTATION PLAN BEFORE OR AT THE PRE-CON AS REQUIRED.
 THE CONTRACTOR SHALL PROVIDE A CONSTRUCTION DEWATERING PLAN AS PART OF THE EROSION CONTROL IMPLEMENTATION PLAN.
 POLYMER SHALL BE APPLIED TO DISTURBED AREAS AS DIRECTED BY THE CONSTRUCTION ENGINEER.

-  STREET CONSTRUCTION ENTRANCE BERM
-  CONSTRUCTION ENTRANCE
-  TYPE D HYBRID INLET PROTECTION
-  TYPE C INLET PROTECTION
-  SILT SOCK (VELOCITY CHECK)
-  STREET CONSTRUCTION STONE BERM

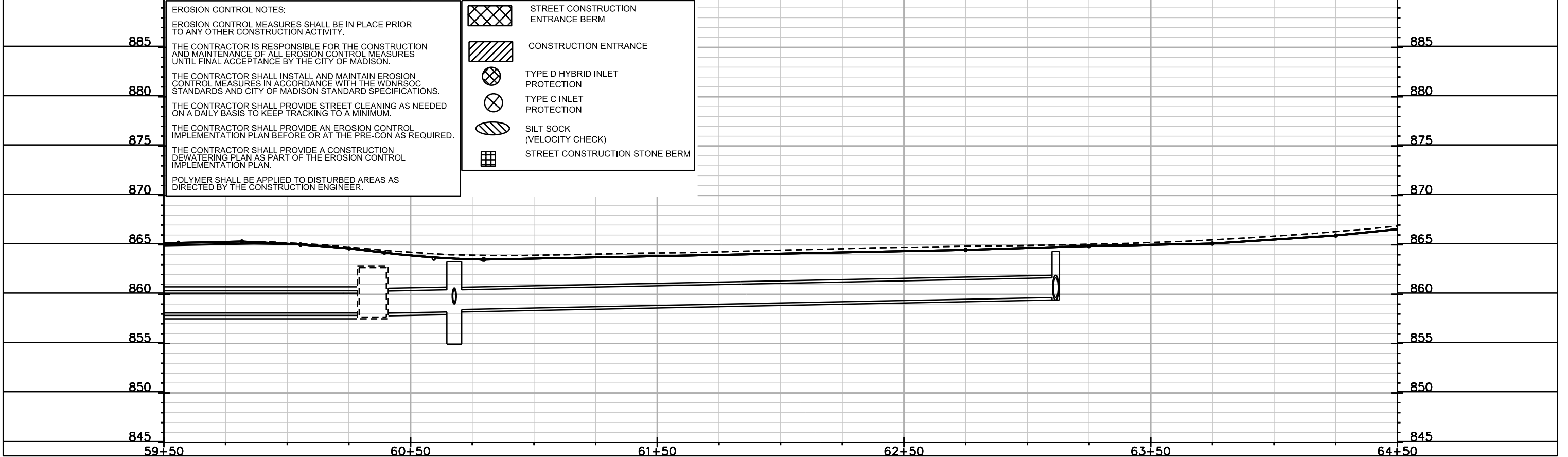

PLOT SCALE: _____

PLOT NAME: _____

REV. DATE: _____

ORIGINATOR: CITY OF MADISON, STREETS DIVISION

EROSION CONTROL PLAN
DEMPSEY ROAD CITY OF MADISON

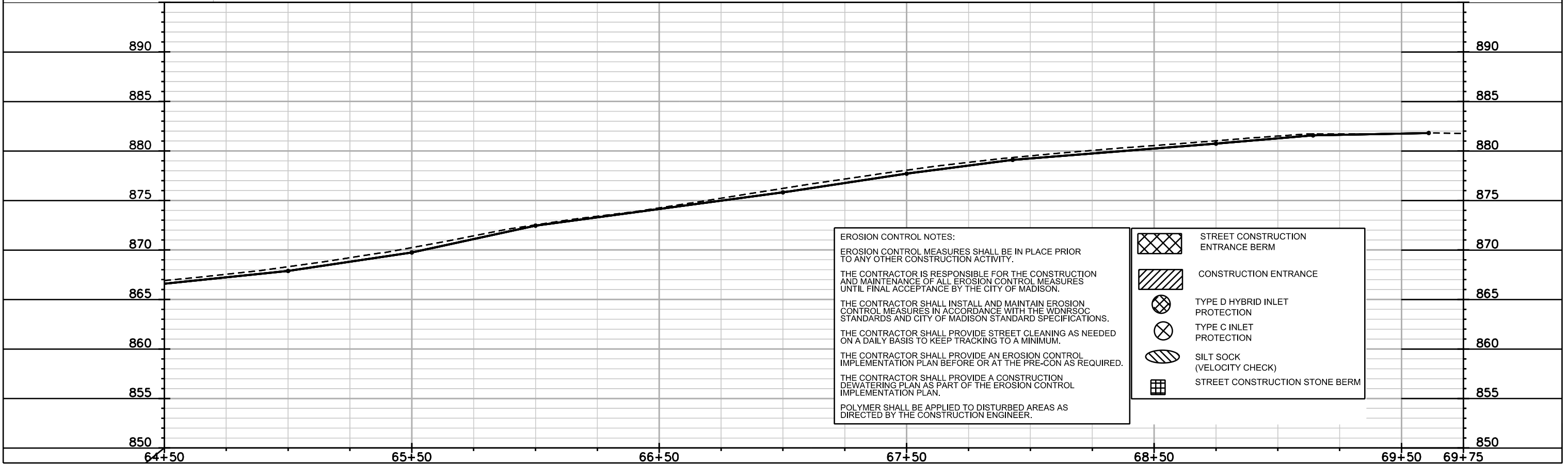
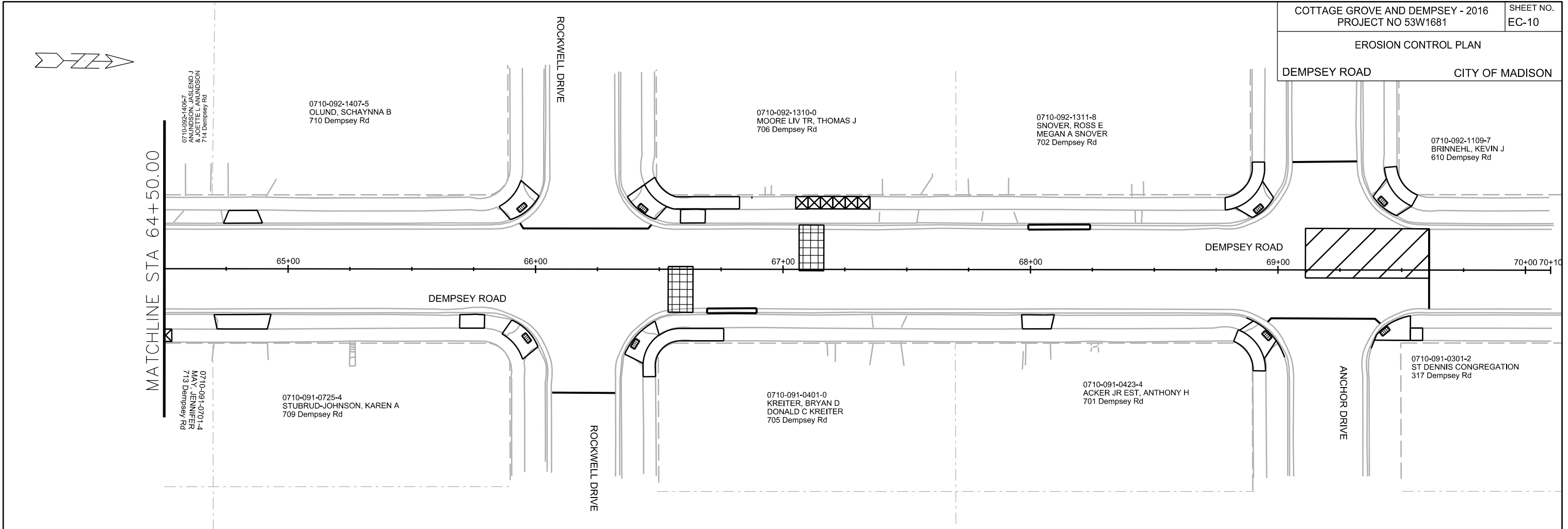

EROSION CONTROL NOTES:

EROSION CONTROL MEASURES SHALL BE IN PLACE PRIOR TO ANY OTHER CONSTRUCTION ACTIVITY.

THE CONTRACTOR IS RESPONSIBLE FOR THE CONSTRUCTION AND MAINTENANCE OF ALL EROSION CONTROL MEASURES UNTIL FINAL ACCEPTANCE BY THE CITY OF MADISON.

THE CONTRACTOR SHALL INSTALL AND MAINTAIN EROSION CONTROL MEASURES IN ACCORDANCE WITH THE WDNR SOC STANDARDS AND CITY OF MADISON STANDARD SPECIFICATIONS.

THE CONTRACTOR SHALL PROVIDE STREET CLEANING AS NEEDED ON A DAILY BASIS TO KEEP TRACKING TO A MINIMUM.

THE CONTRACTOR SHALL PROVIDE AN EROSION CONTROL IMPLEMENTATION PLAN BEFORE OR AT THE PRE-CON AS REQUIRED.

THE CONTRACTOR SHALL PROVIDE A CONSTRUCTION DEWATERING PLAN AS PART OF THE EROSION CONTROL IMPLEMENTATION PLAN.

POLYMER SHALL BE APPLIED TO DISTURBED AREAS AS DIRECTED BY THE CONSTRUCTION ENGINEER.

| | |
|--|-----------------------------------|
| | STREET CONSTRUCTION ENTRANCE BERM |
| | CONSTRUCTION ENTRANCE |
| | TYPE D HYBRID INLET PROTECTION |
| | TYPE C INLET PROTECTION |
| | SILT SOCK (VELOCITY CHECK) |
| | STREET CONSTRUCTION STONE BERM |

PLOT SCALE: _____

PLOT NAME: _____

REV. DATE: _____

ORIGINATOR: CITY OF MADISON, STREETS DIVISION

PLAN AND PROFILE
COTTAGE GROVE ROAD CITY OF MADISON

REVISED 8/4/16 LRC
REV. MEDIAN LANDSCAPING

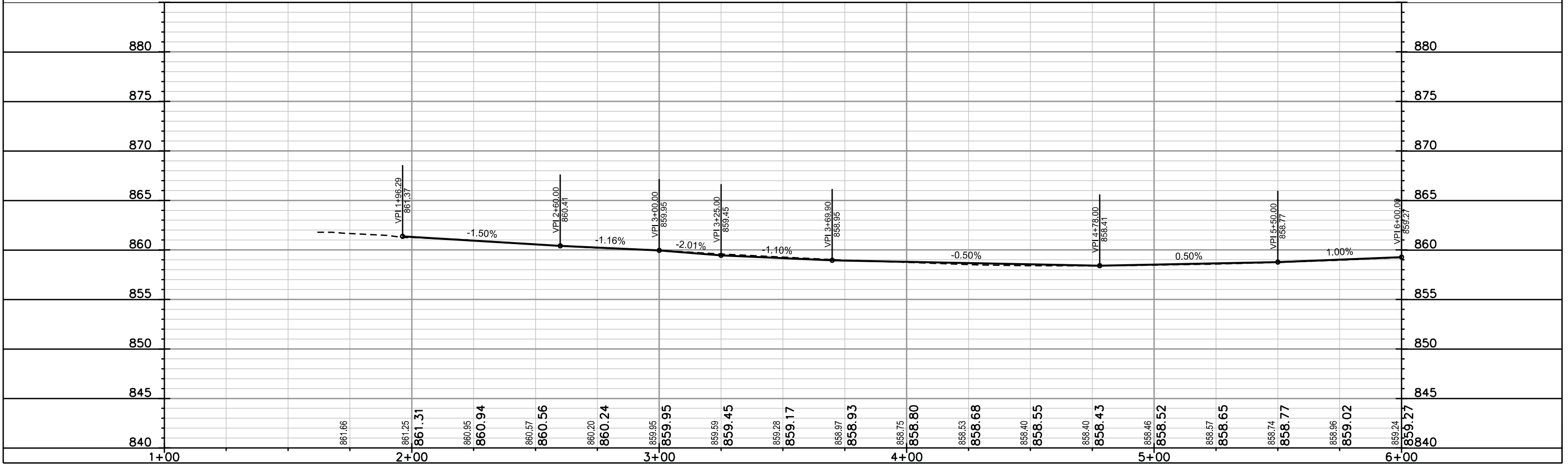
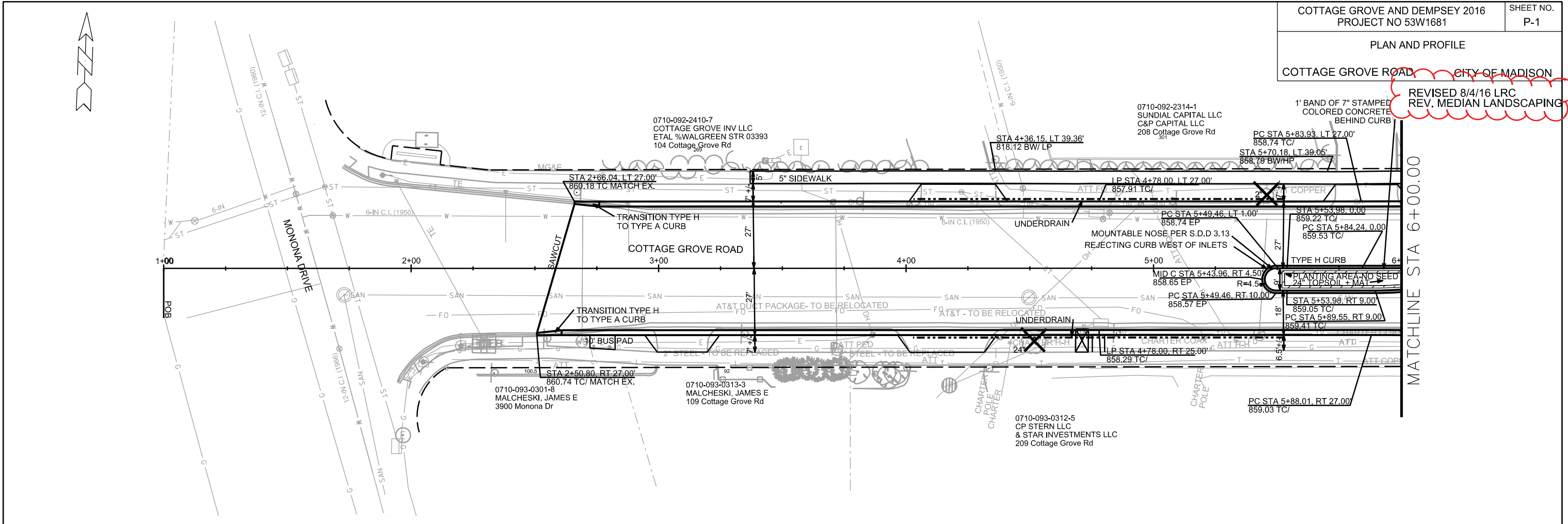

PLOT SCALE: _____

PLOT NAME: _____

REV. DATE: _____

ORIGINATOR: CITY OF MADISON, STREETS DIVISION

PLAN AND PROFILE
COTTAGE GROVE ROAD CITY OF MADISON

REVISED 6/8/16 LRC
REVISED 7/5/16 LRC
REVISED 8/4/16 LRC
REV. MEDIAN LANDSCAPING

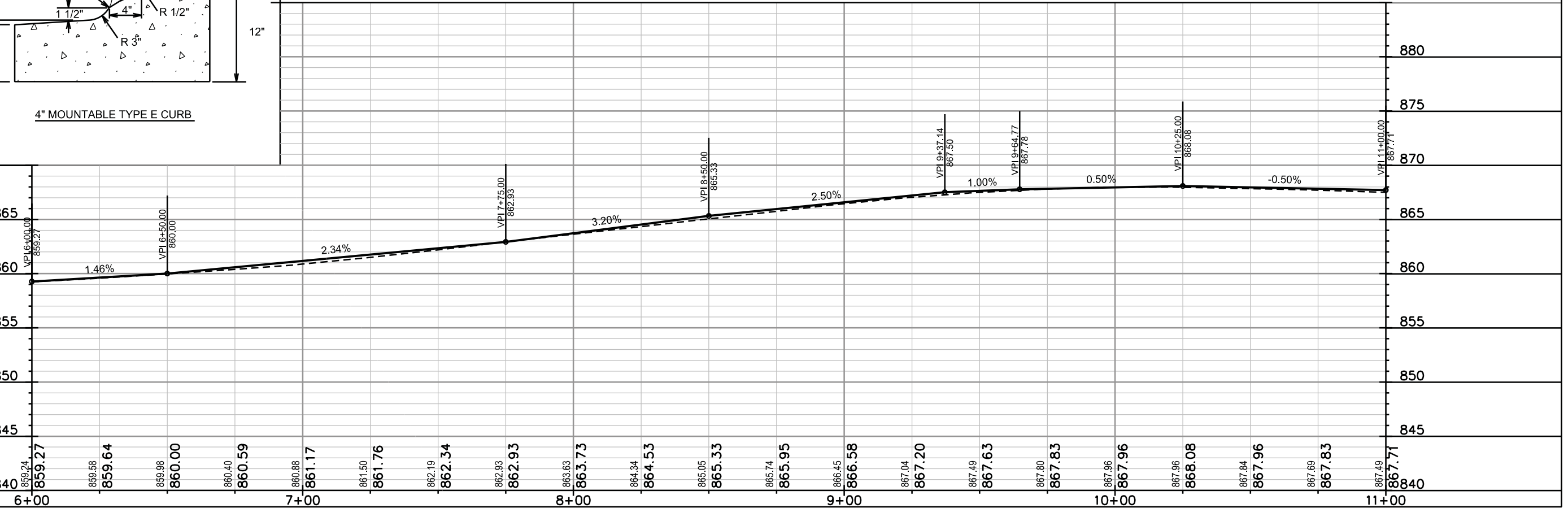
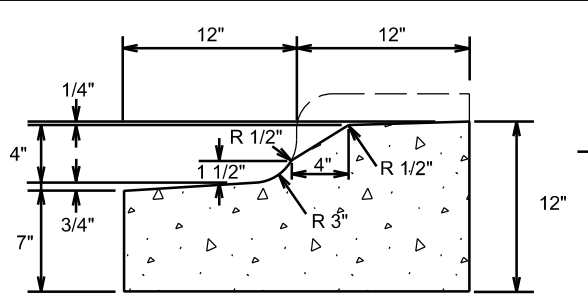
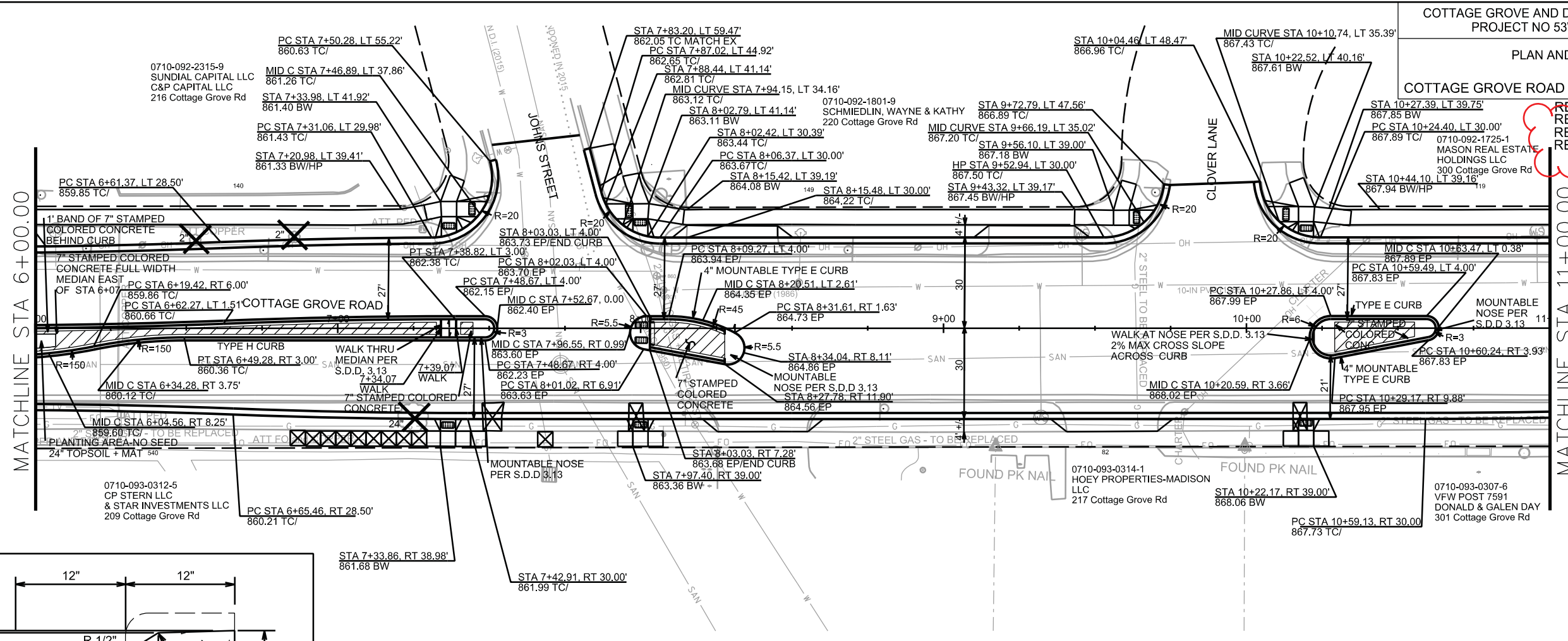

ORIGINATOR: CITY OF MADISON, STREETS DIVISION
REV. DATE: _____
PLOT SCALE: _____
PLOT NAME: _____

PLAN AND PROFILE
COTTAGE GROVE ROAD CITY OF MADISON
REVISED 8/4/16 LRC
REV. MEDIAN LANDSCAPING

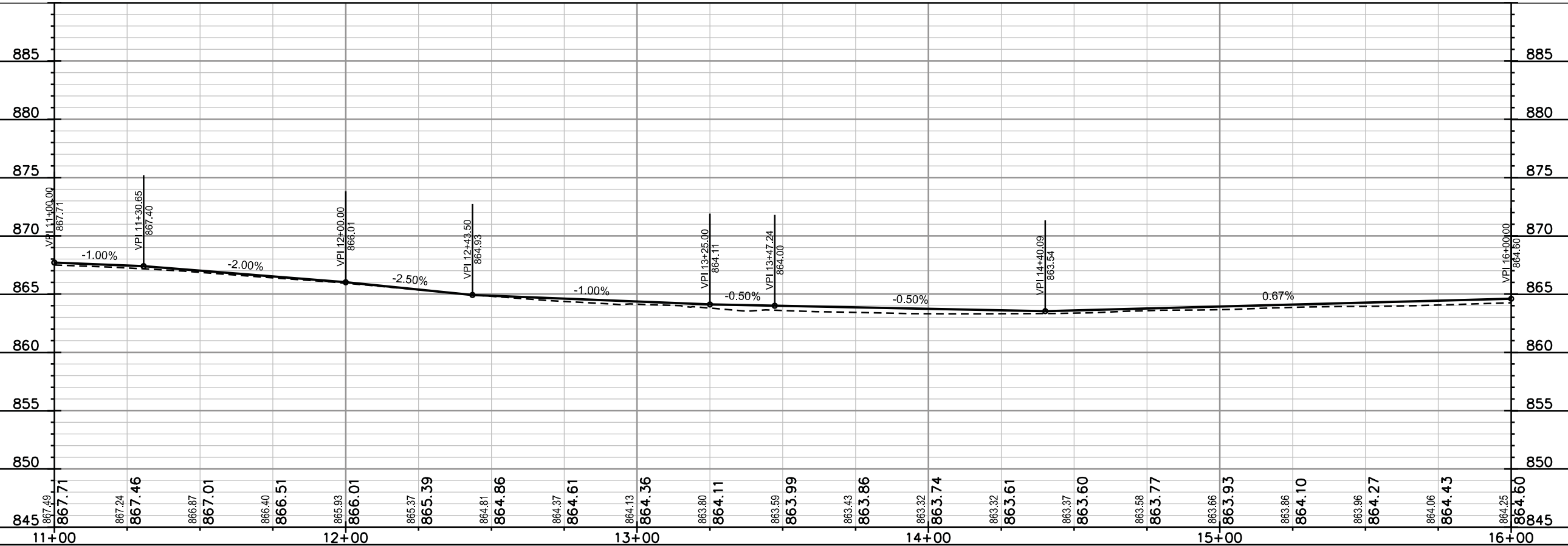
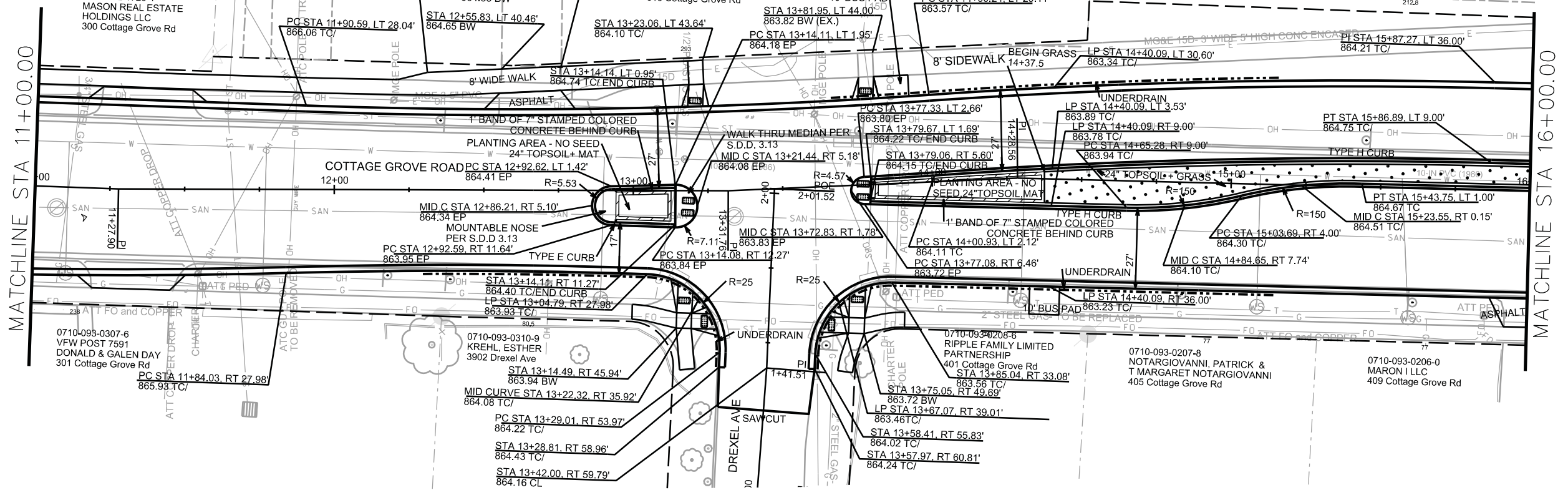

PLOT SCALE: _____

REV. DATE: _____

ORIGINATOR: CITY OF MADISON, STREETS DIVISION

PLAN AND PROFILE
COTTAGE GROVE ROAD CITY OF MADISON
REVISED 8/4/16 LRC
REV. MEDIAN LANDSCAPING

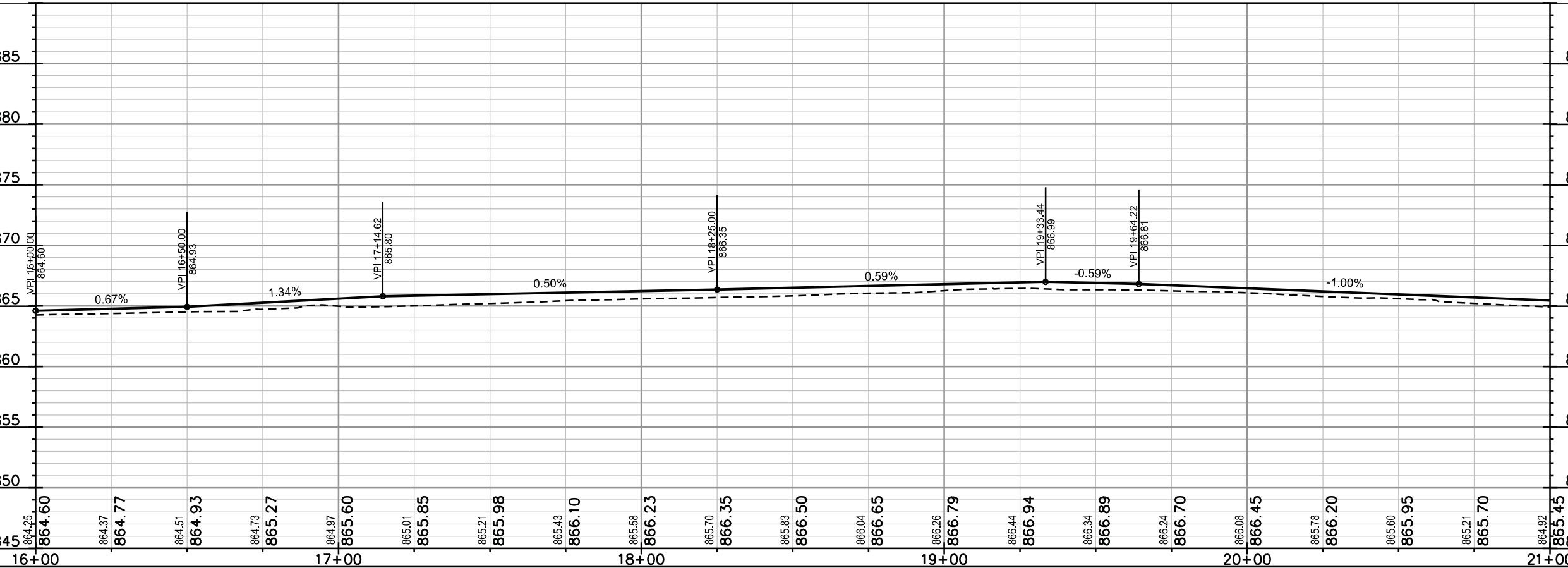
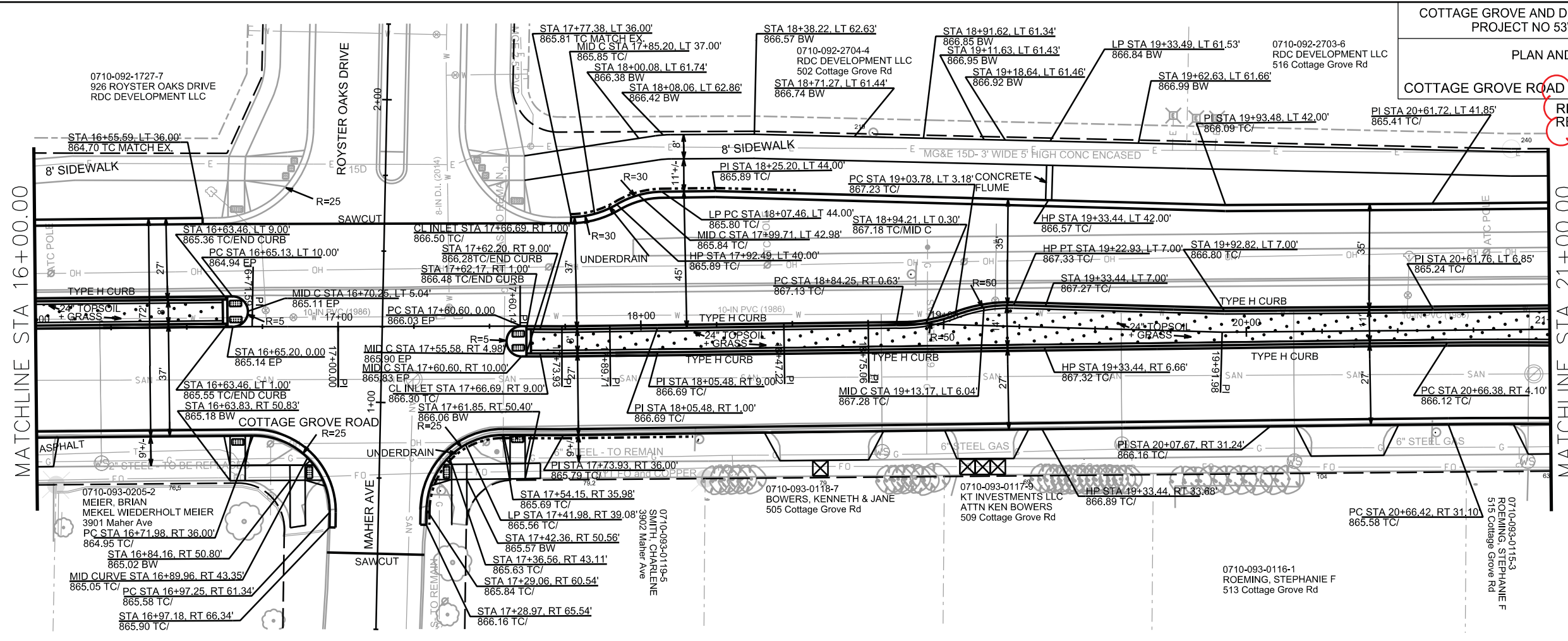

PLOT SCALE: _____

REV. DATE: _____

ORIGINATOR: CITY OF MADISON, STREETS DIVISION

PLAN AND PROFILE

COTTAGE GROVE ROAD CITY OF MADISON

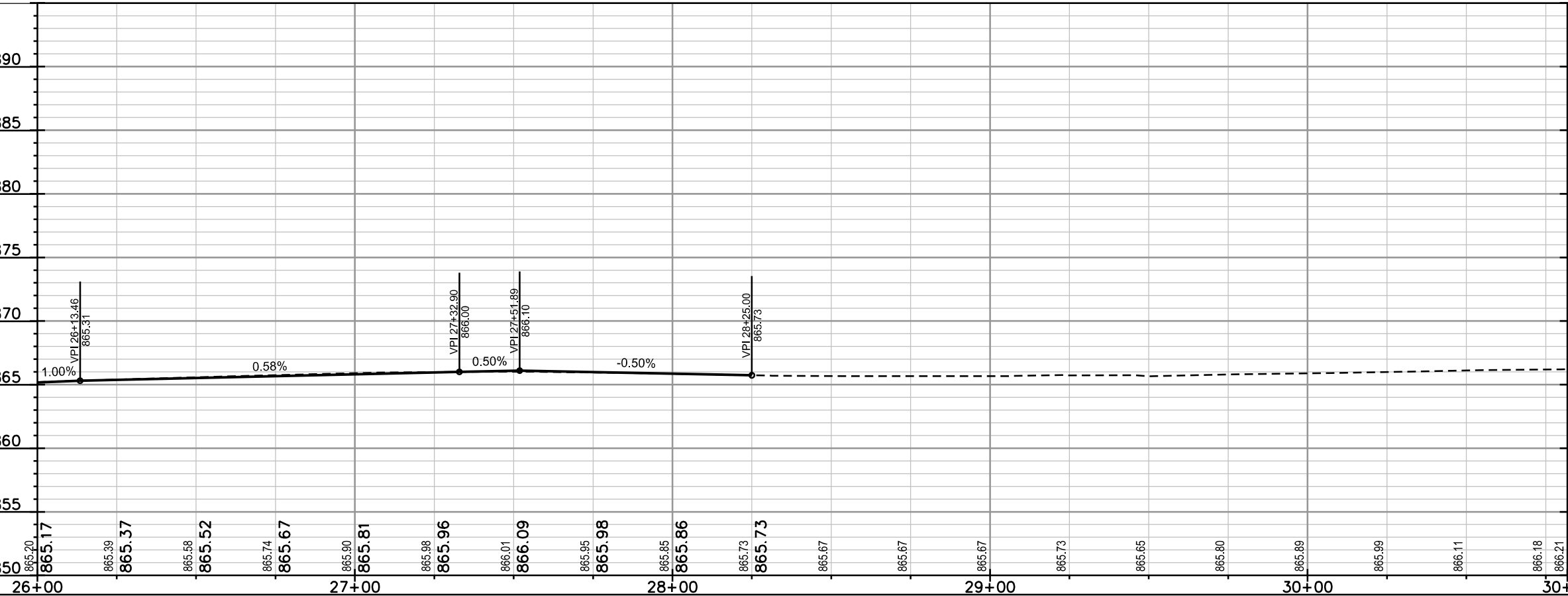
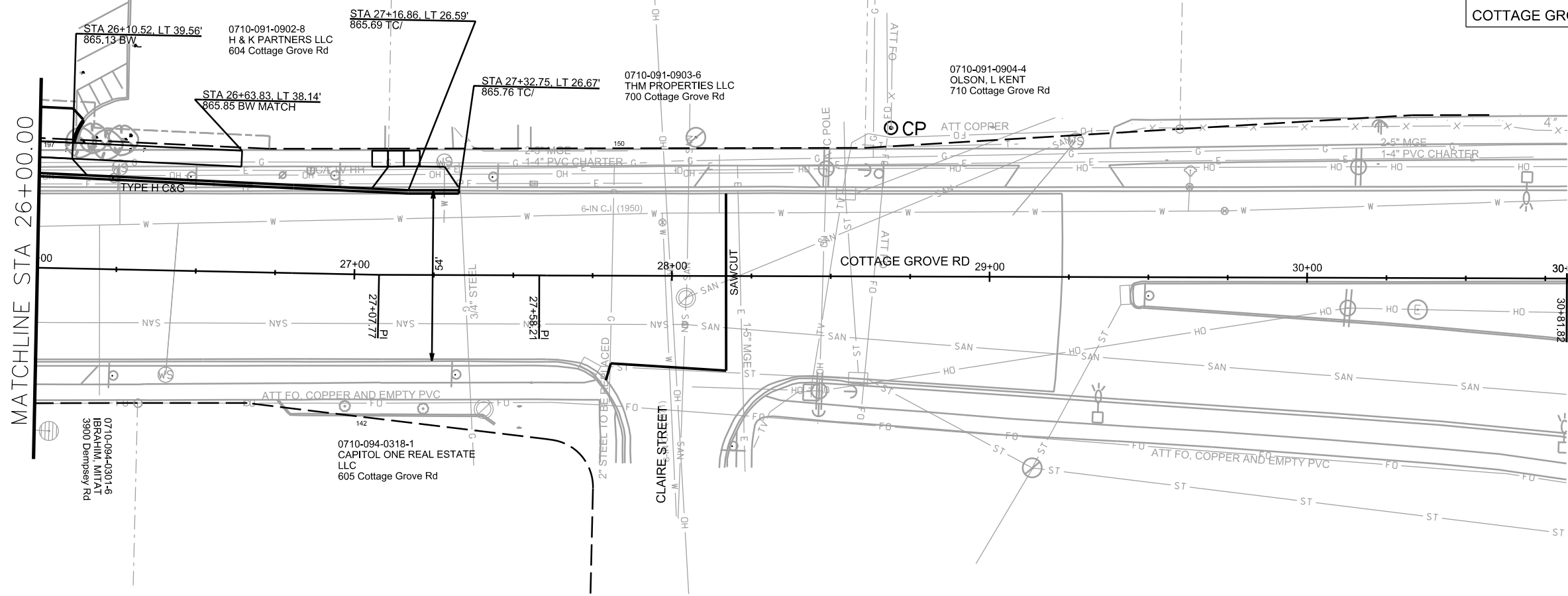

PLOT SCALE: _____

PLOT NAME: _____

REV. DATE: _____

ORIGINATOR: CITY OF MADISON, STREETS DIVISION

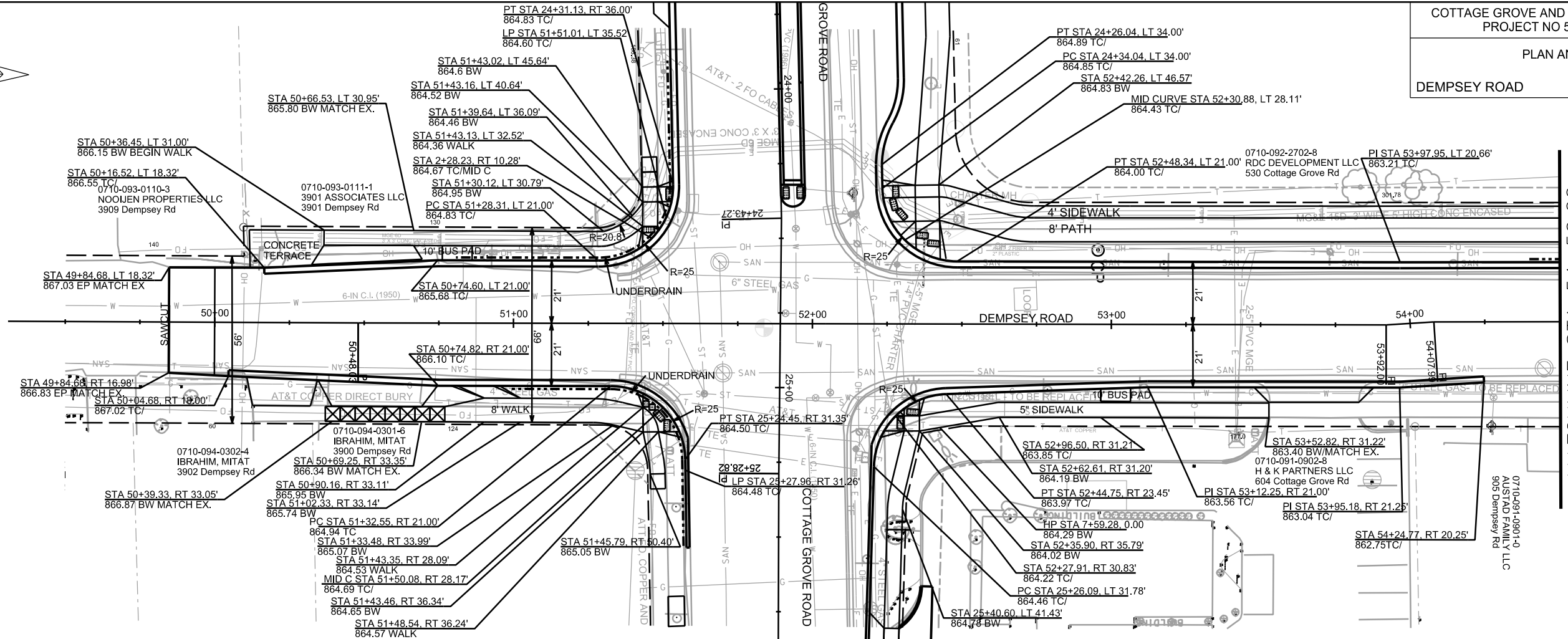
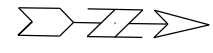

PLOT NAME: _____

REV. DATE: _____

ORIGINATOR: CITY OF MADISON, STREETS DIVISION

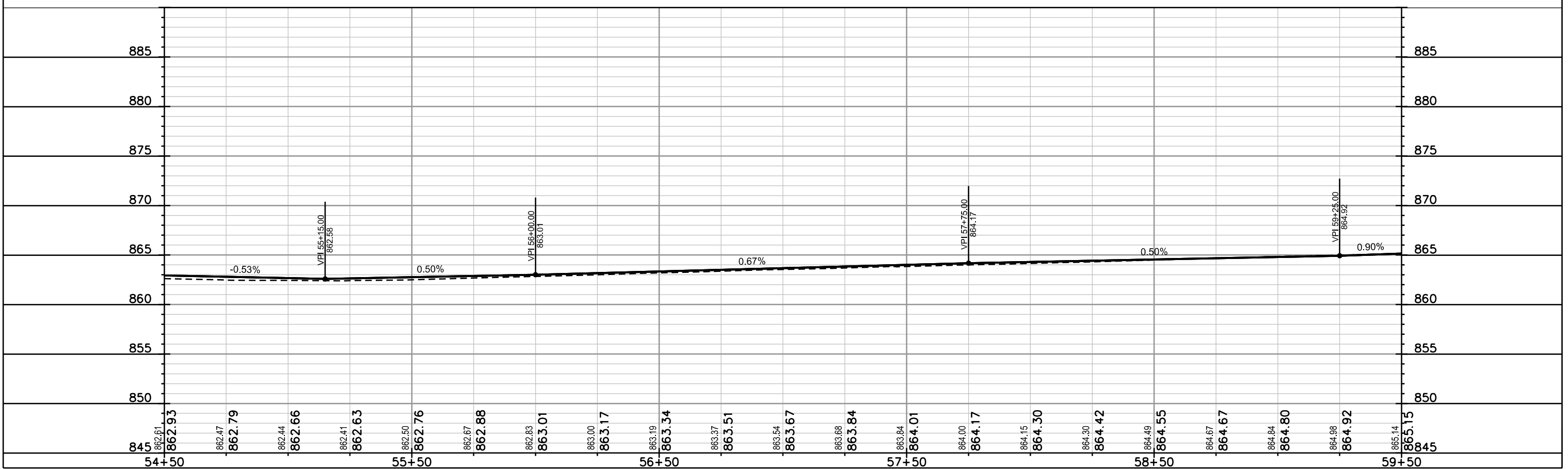
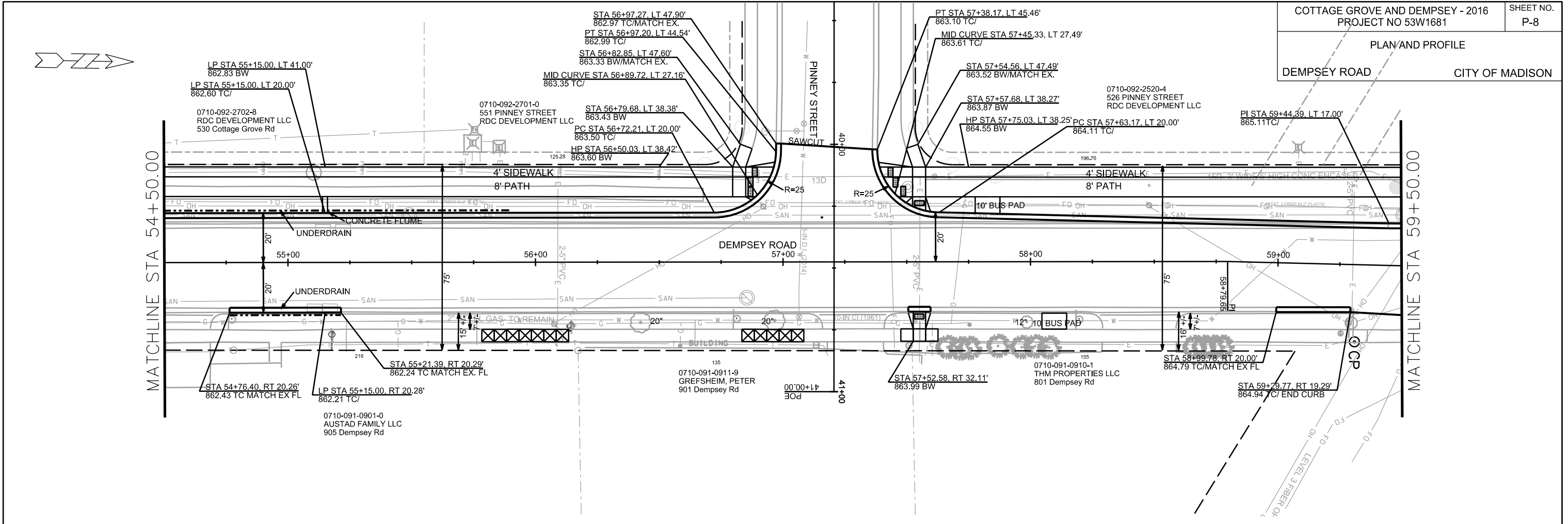

PLOT SCALE: _____

PLOT NAME: _____

REV. DATE: _____

ORIGINATOR: CITY OF MADISON, STREETS DIVISION

PLAN AND PROFILE
DEMPSEY ROAD
CITY OF MADISON

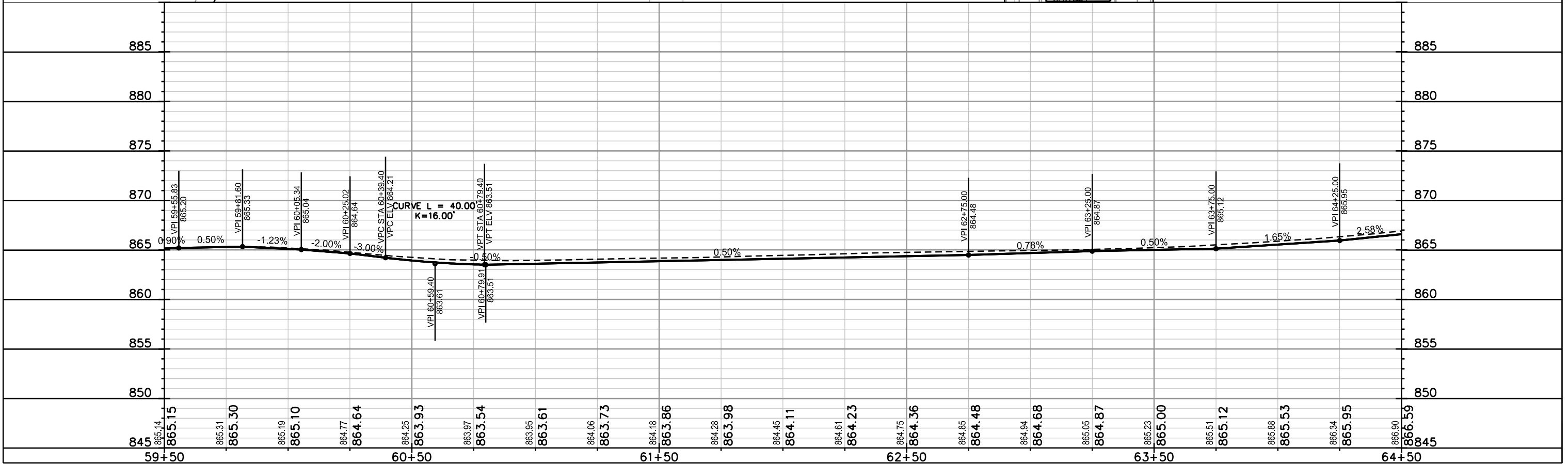
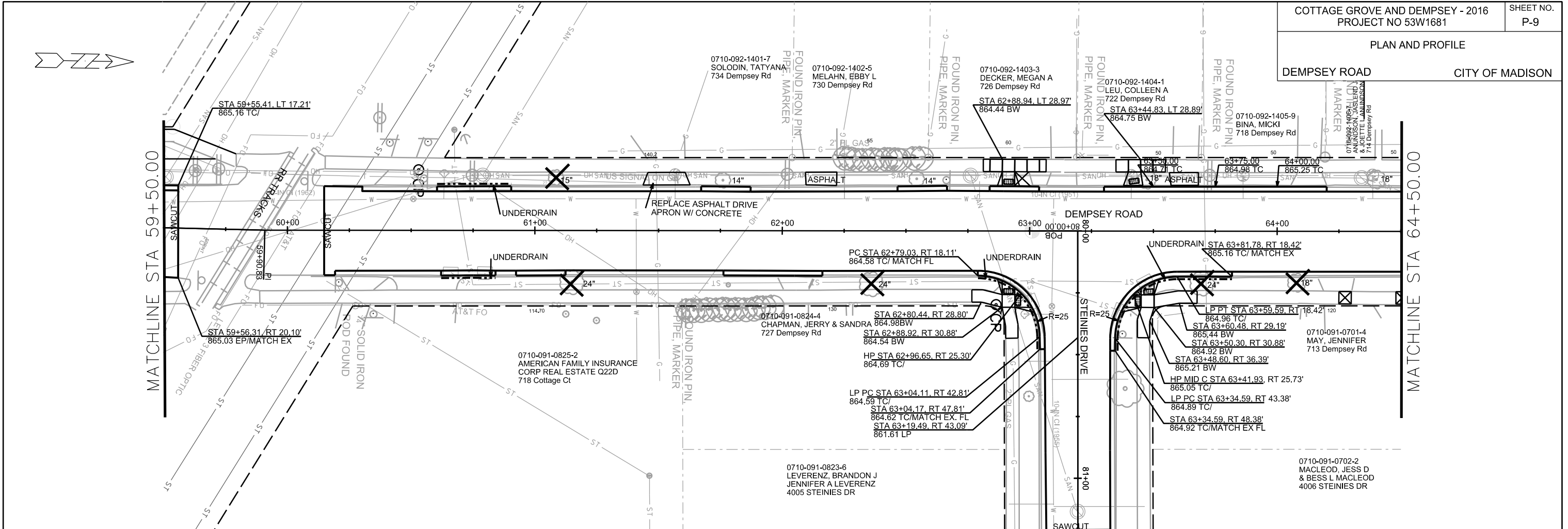

PLOT SCALE: _____
 PLOT NAME: _____
 REV. DATE: _____
 ORIGINATOR: CITY OF MADISON, STREETS DIVISION

PLAN AND PROFILE
DEMPSEY ROAD CITY OF MADISON

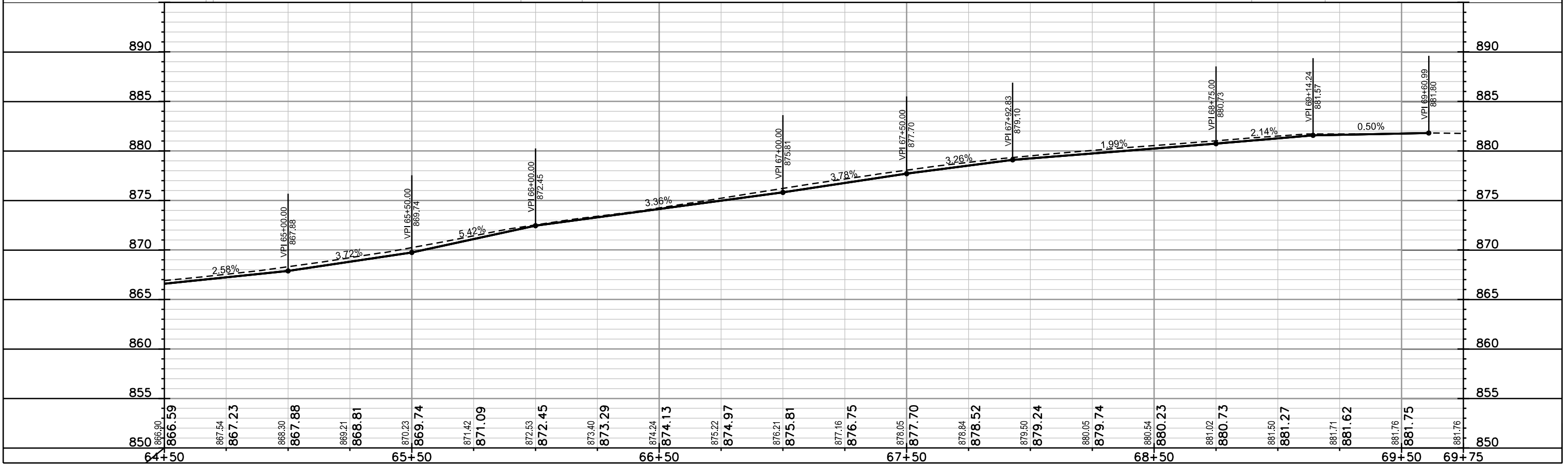
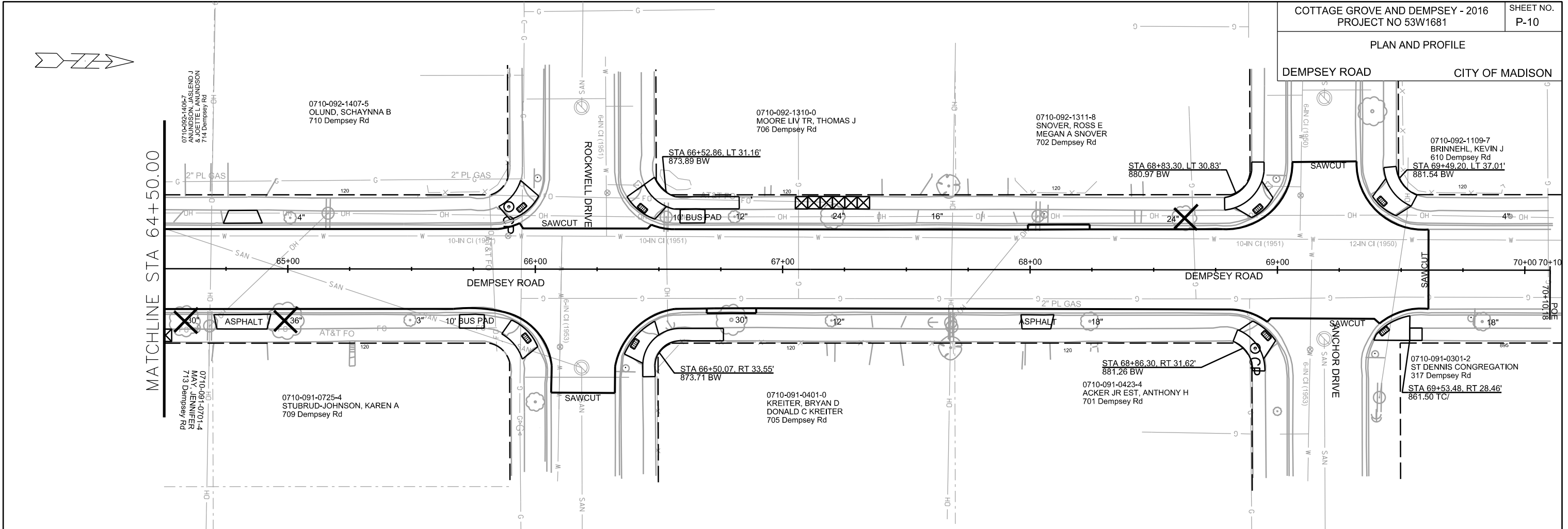

PLOT SCALE: _____

PLOT NAME: _____

REV. DATE: _____

ORIGINATOR: CITY OF MADISON, STREETS DIVISION



| Callout | Bid Item | Description |
|---------|----------|-----------------------------------------------------------------|
| 1 | 60802 | Pavement Marking Epoxy, 6-Inch White Skips, (10' Line, 30' Gap) |
| 2 | 60800 | Pavement Marking Epoxy, 4-Inch, Solid Yellow |
| 3 | 60814 | Pavement Marking Epoxy, 12-Inch White Crosswalk |
| 4 | 60803 | Pavement Marking Epoxy, 8-Inch Solid White |
| 5 | 60803 | Pavement Marking Epoxy, 8-Inch White Skips, (5' Line, 5' Gap) |
| 6 | 60834 | Pavement Marking Epoxy, Word, "ONLY" |
| 7 | 60835 | Pavement Marking Epoxy, Symbol, Railroad Crossing |
| 8 | 60803 | Pavement Marking Epoxy, 8-Inch White Skips, (2' Line, 6' Gap) |
| 9 | 60818 | Pavement Marking Epoxy, 24-Inch White, Stop Line |
| 10 | 60812 | Pavement Marking Epoxy, 6-Inch White, Crosswalk |
| 11 | 60816 | Pavement Marking Epoxy, 18-Inch White, Continental Crosswalk |
| 12 | 60823 | Pavement Marking Epoxy, Symbol, Bike Lane |
| 13 | 60801 | Pavement Marking Epoxy, 4-Inch Double Yellow |
| 14 | 60802 | Pavement Marking Epoxy, 6-Inch Yellow Skips (10' Line, 30' Gap) |
| 15 | 60829 | Pavement Marking Epoxy, Symbol, Left Arrow |
| 16 | 60826 | Pavement Marking Epoxy, Symbol, Bike Lane & Straight Arrow |
| 17 | 60802 | Pavement Marking Epoxy, 6-Inch Solid White |
| 18 | 60802 | Pavement Marking Epoxy, 6-Inch White Skips (5' Line, 5' Gap) |
| 19 | 60802 | Pavement Marking Epoxy, 6-Inch White Skips (2' Line, 6' Gap) |
| 20 | 60800 | Pavement Marking Epoxy, 4-Inch Yellow Skips (10' Line, 30' Gap) |
| 21 | 60815 | Pavement Marking Epoxy, Crosswalk, 18-Inch |

Contact Tom Mohr, city traffic engineering, 608-267-8725
with pavement marking layout questions

All markings are measured to face of curb and
center of marking

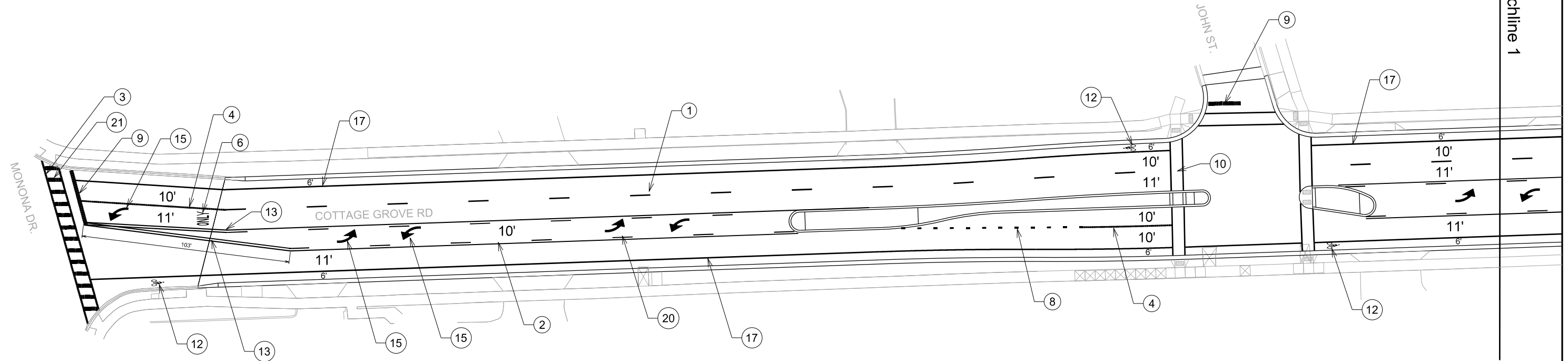

PLOT SCALE:

PLOT NAME:

REV. DATE:

ORIGINATOR: CITY OF MADISON, TRAFFIC ENG. DIV.



| Callout | Bid Item | Description |
|---------|----------|-----------------------------------------------------------------|
| 1 | 60802 | Pavement Marking Epoxy, 6-Inch White Skips, (10' Line, 30' Gap) |
| 2 | 60800 | Pavement Marking Epoxy, 4-Inch, Solid Yellow |
| 3 | 60814 | Pavement Marking Epoxy, 12-Inch White Crosswalk |
| 4 | 60803 | Pavement Marking Epoxy, 8-Inch Solid White |
| 5 | 60803 | Pavement Marking Epoxy, 8-Inch White Skips, (5' Line, 5' Gap) |
| 6 | 60834 | Pavement Marking Epoxy, Word, "ONLY" |
| 7 | 60835 | Pavement Marking Epoxy, Symbol, Railroad Crossing |
| 8 | 60803 | Pavement Marking Epoxy, 8-Inch White Skips, (2' Line, 6' Gap) |
| 9 | 60818 | Pavement Marking Epoxy, 24-Inch White, Stop Line |
| 10 | 60812 | Pavement Marking Epoxy, 6-Inch White, Crosswalk |
| 11 | 60816 | Pavement Marking Epoxy, 18-Inch White, Continental Crosswalk |
| 12 | 60823 | Pavement Marking Epoxy, Symbol, Bike Lane |
| 13 | 60801 | Pavement Marking Epoxy, 4-Inch Double Yellow |
| 14 | 60802 | Pavement Marking Epoxy, 6-Inch Yellow Skips (10' Line, 30' Gap) |
| 15 | 60829 | Pavement Marking Epoxy, Symbol, Left Arrow |
| 16 | 60826 | Pavement Marking Epoxy, Symbol, Bike Lane & Straight Arrow |
| 17 | 60802 | Pavement Marking Epoxy, 6-Inch Solid White |
| 18 | 60802 | Pavement Marking Epoxy, 6-Inch White Skips (5' Line, 5' Gap) |
| 19 | 60802 | Pavement Marking Epoxy, 6-Inch White Skips (2' Line, 6' Gap) |
| 20 | 60800 | Pavement Marking Epoxy, 4-Inch Yellow Skips (10' Line, 30' Gap) |
| 21 | 60815 | Pavement Marking Epoxy, Crosswalk, 18-Inch |

Contact Tom Mohr, city traffic engineering, 608-267-8725
with pavement marking layout questions

All markings are measured to face of curb and
center of marking

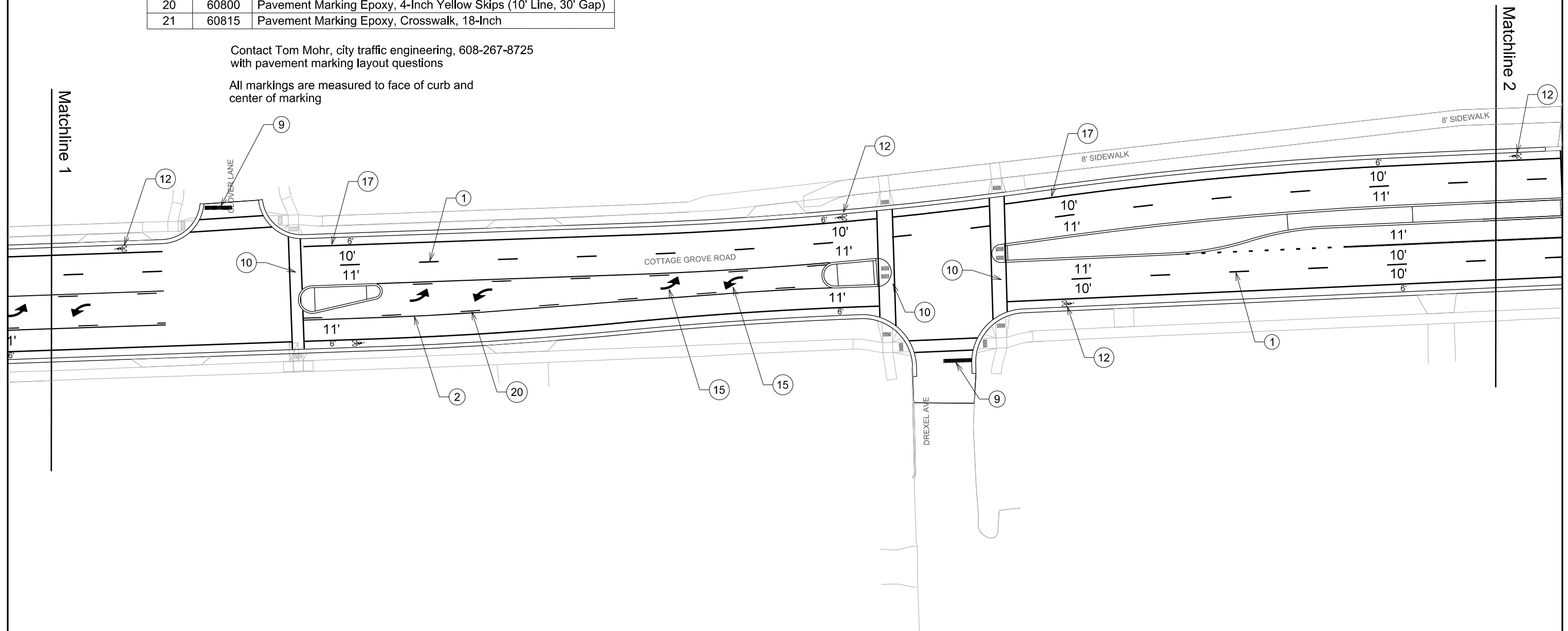

PLOT SCALE:

PLOT NAME:

REV. DATE:

ORIGINATOR: CITY OF MADISON, TRAFFIC ENG. DIV.



| | | |
|----|-------|-----------------------------------------------------------------|
| 4 | 60803 | Pavement Marking Epoxy, 8-Inch Solid White |
| 5 | 60803 | Pavement Marking Epoxy, 8-Inch White Skips, (5' Line, 5' Gap) |
| 6 | 60834 | Pavement Marking Epoxy, Word, "ONLY" |
| 7 | 60835 | Pavement Marking Epoxy, Symbol, Railroad Crossing |
| 8 | 60803 | Pavement Marking Epoxy, 8-Inch White Skips, (2' Line, 6' Gap) |
| 9 | 60818 | Pavement Marking Epoxy, 24-Inch White, Stop Line |
| 10 | 60812 | Pavement Marking Epoxy, 6-Inch White, Crosswalk |
| 11 | 60816 | Pavement Marking Epoxy, 18-Inch White, Continental Crosswalk |
| 12 | 60823 | Pavement Marking Epoxy, Symbol, Bike Lane |
| 13 | 60801 | Pavement Marking Epoxy, 4-Inch Double Yellow |
| 14 | 60802 | Pavement Marking Epoxy, 6-Inch Yellow Skips (10' Line, 30' Gap) |
| 15 | 60829 | Pavement Marking Epoxy, Symbol, Left Arrow |
| 16 | 60826 | Pavement Marking Epoxy, Symbol, Bike Lane & Straight Arrow |
| 17 | 60802 | Pavement Marking Epoxy, 6-Inch Solid White |
| 18 | 60802 | Pavement Marking Epoxy, 6-Inch White Skips (5' Line, 5' Gap) |
| 19 | 60802 | Pavement Marking Epoxy, 6-Inch White Skips (2' Line, 6' Gap) |
| 20 | 60800 | Pavement Marking Epoxy, 4-Inch Yellow Skips (10' Line, 30' Gap) |
| 21 | 60815 | Pavement Marking Epoxy, Crosswalk, 18-Inch |

Contact Tom Mohr, city traffic engineering, 608-267-8725
with pavement marking layout questions

All markings are measured to face of curb and
center of marking

PLOT SCALE:

PLOT NAME:

REV. DATE:

ORIGINATOR: CITY OF MADISON, TRAFFIC ENG. DIV.

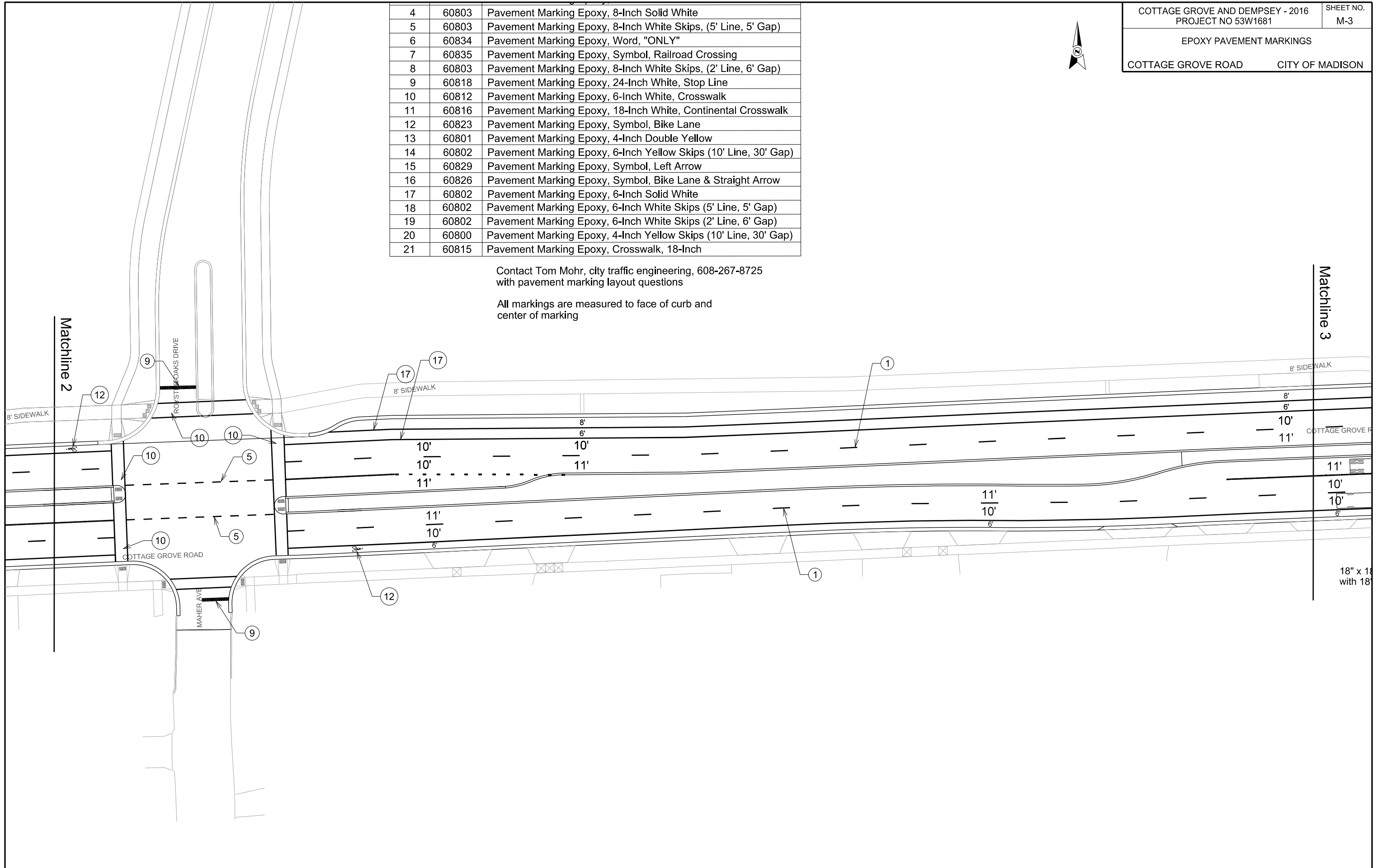

18" x 14"
with 18"

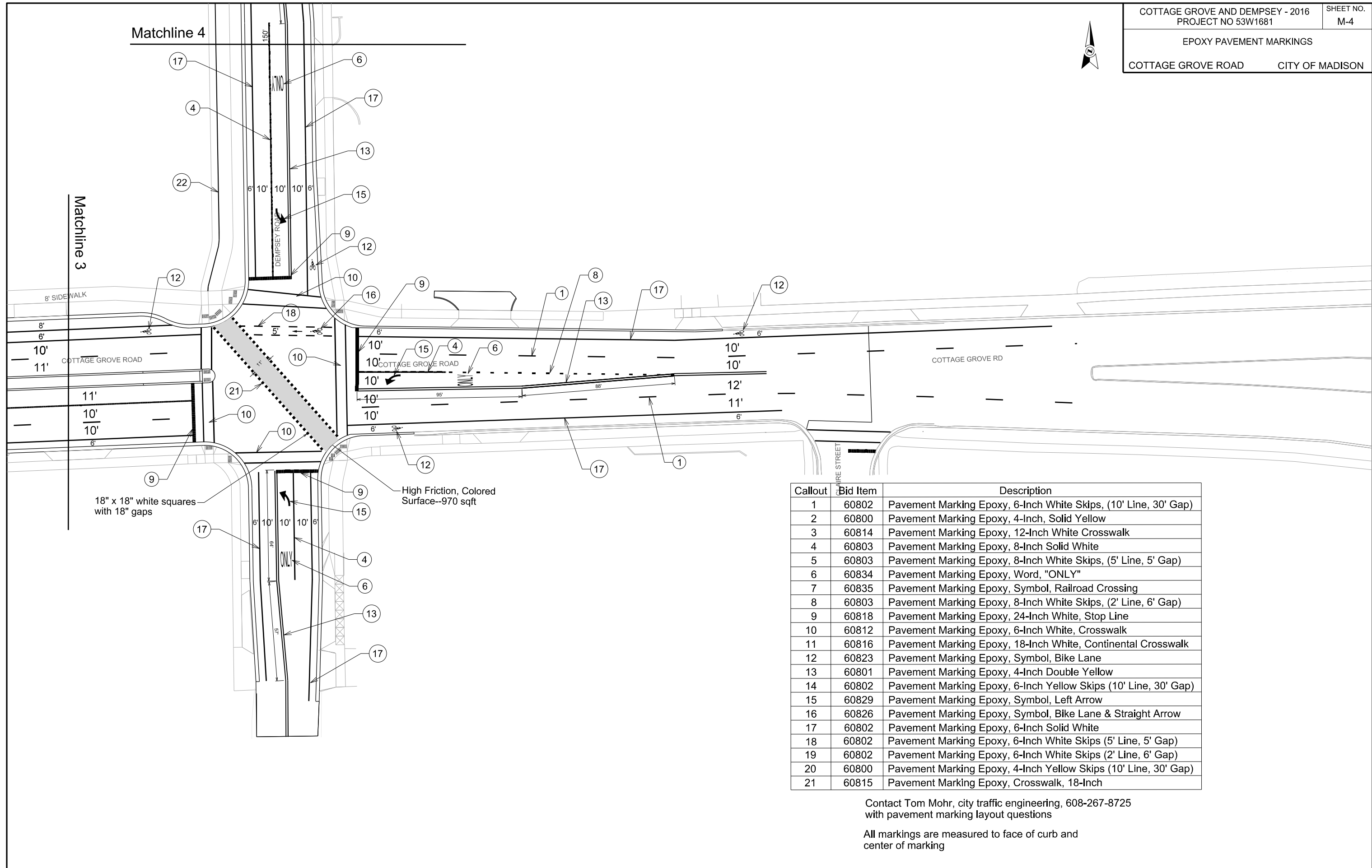

| Callout | Bid Item | Description |
|---------|----------|-----------------------------------------------------------------|
| 1 | 60802 | Pavement Marking Epoxy, 6-Inch White Skips, (10' Line, 30' Gap) |
| 2 | 60800 | Pavement Marking Epoxy, 4-Inch, Solid Yellow |
| 3 | 60814 | Pavement Marking Epoxy, 12-Inch White Crosswalk |
| 4 | 60803 | Pavement Marking Epoxy, 8-Inch Solid White |
| 5 | 60803 | Pavement Marking Epoxy, 8-Inch White Skips, (5' Line, 5' Gap) |
| 6 | 60834 | Pavement Marking Epoxy, Word, "ONLY" |
| 7 | 60835 | Pavement Marking Epoxy, Symbol, Railroad Crossing |
| 8 | 60803 | Pavement Marking Epoxy, 8-Inch White Skips, (2' Line, 6' Gap) |
| 9 | 60818 | Pavement Marking Epoxy, 24-Inch White, Stop Line |
| 10 | 60812 | Pavement Marking Epoxy, 6-Inch White, Crosswalk |
| 11 | 60816 | Pavement Marking Epoxy, 18-Inch White, Continental Crosswalk |
| 12 | 60823 | Pavement Marking Epoxy, Symbol, Bike Lane |
| 13 | 60801 | Pavement Marking Epoxy, 4-Inch Double Yellow |
| 14 | 60802 | Pavement Marking Epoxy, 6-Inch Yellow Skips (10' Line, 30' Gap) |
| 15 | 60829 | Pavement Marking Epoxy, Symbol, Left Arrow |
| 16 | 60826 | Pavement Marking Epoxy, Symbol, Bike Lane & Straight Arrow |
| 17 | 60802 | Pavement Marking Epoxy, 6-Inch Solid White |
| 18 | 60802 | Pavement Marking Epoxy, 6-Inch White Skips (5' Line, 5' Gap) |
| 19 | 60802 | Pavement Marking Epoxy, 6-Inch White Skips (2' Line, 6' Gap) |
| 20 | 60800 | Pavement Marking Epoxy, 4-Inch Yellow Skips (10' Line, 30' Gap) |
| 21 | 60815 | Pavement Marking Epoxy, Crosswalk, 18-Inch |

Contact Tom Mohr, city traffic engineering, 608-267-8725
with pavement marking layout questions

All markings are measured to face of curb and
center of marking

PLOT SCALE:

PLOT NAME:

REV. DATE:

ORIGINATOR: CITY OF MADISON, TRAFFIC ENG. DIV.

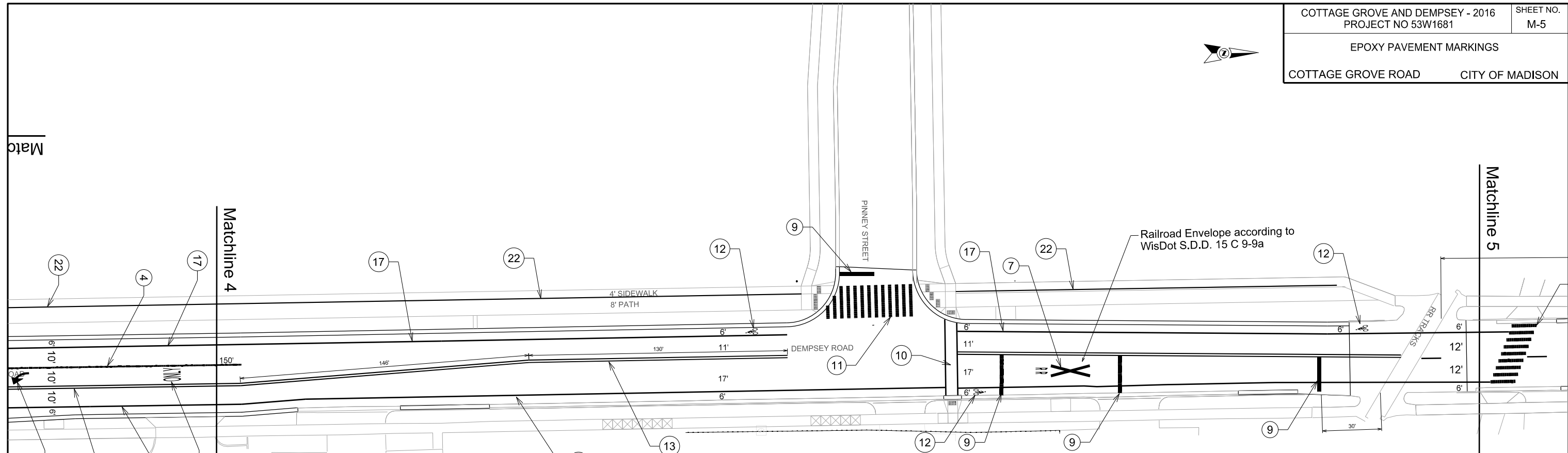

| Callout | Bid Item | Description |
|---------|----------|-----------------------------------------------------------------|
| 1 | 60802 | Pavement Marking Epoxy, 6-Inch White Skips, (10' Line, 30' Gap) |
| 2 | 60800 | Pavement Marking Epoxy, 4-Inch, Solid Yellow |
| 3 | 60814 | Pavement Marking Epoxy, 12-Inch White Crosswalk |
| 4 | 60803 | Pavement Marking Epoxy, 8-Inch Solid White |
| 5 | 60803 | Pavement Marking Epoxy, 8-Inch White Skips, (5' Line, 5' Gap) |
| 6 | 60834 | Pavement Marking Epoxy, Word, "ONLY" |
| 7 | 60835 | Pavement Marking Epoxy, Symbol, Railroad Crossing |
| 8 | 60803 | Pavement Marking Epoxy, 8-Inch White Skips, (2' Line, 6' Gap) |
| 9 | 60818 | Pavement Marking Epoxy, 24-Inch White, Stop Line |
| 10 | 60812 | Pavement Marking Epoxy, 6-Inch White, Crosswalk |
| 11 | 60816 | Pavement Marking Epoxy, 18-Inch White, Continental Crosswalk |
| 12 | 60823 | Pavement Marking Epoxy, Symbol, Bike Lane |
| 13 | 60801 | Pavement Marking Epoxy, 4-Inch Double Yellow |
| 14 | 60802 | Pavement Marking Epoxy, 6-Inch Yellow Skips (10' Line, 30' Gap) |
| 15 | 60829 | Pavement Marking Epoxy, Symbol, Left Arrow |
| 16 | 60826 | Pavement Marking Epoxy, Symbol, Bike Lane & Straight Arrow |
| 17 | 60802 | Pavement Marking Epoxy, 6-Inch Solid White |
| 18 | 60802 | Pavement Marking Epoxy, 6-Inch White Skips (5' Line, 5' Gap) |
| 19 | 60802 | Pavement Marking Epoxy, 6-Inch White Skips (2' Line, 6' Gap) |
| 20 | 60800 | Pavement Marking Epoxy, 4-Inch Yellow Skips (10' Line, 30' Gap) |
| 21 | 60815 | Pavement Marking Epoxy, Crosswalk, 18-Inch |
| 22 | 60800 | Pavement Marking Epoxy, 4-Inch, Solid White |

Contact Tom Mohr, city traffic engineering, 608-267-8725
with pavement marking layout questions

All markings are measured to face of curb and
center of marking

PLOT SCALE:

PLOT NAME:

REV. DATE:

ORIGINATOR: CITY OF MADISON, TRAFFIC ENG. DIV.

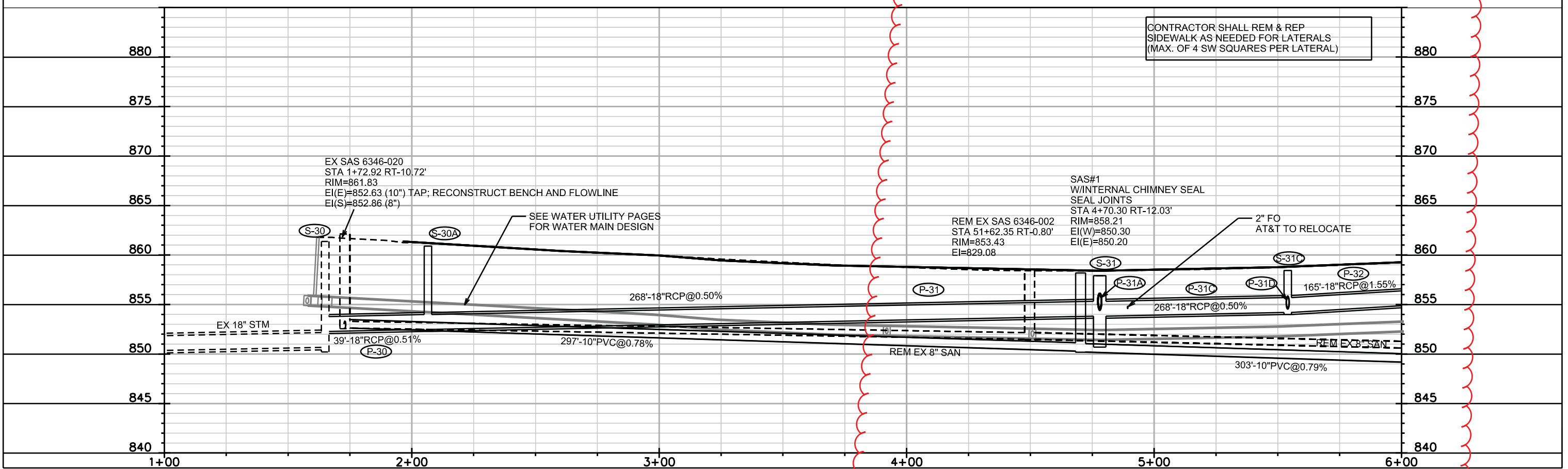
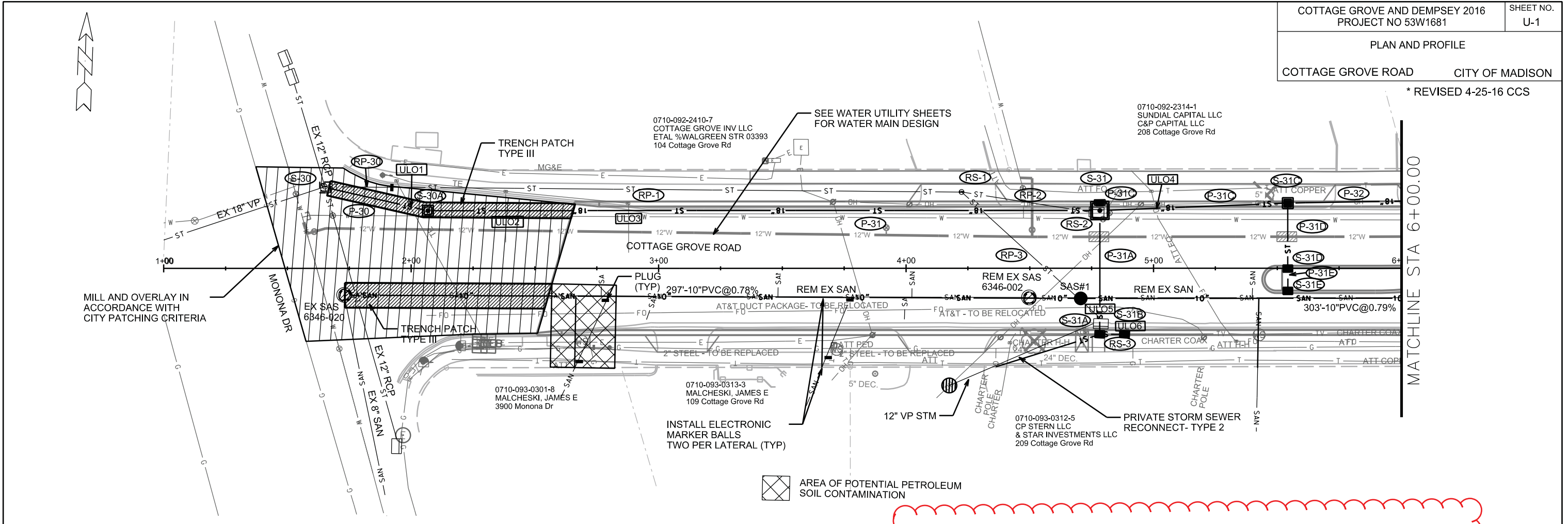

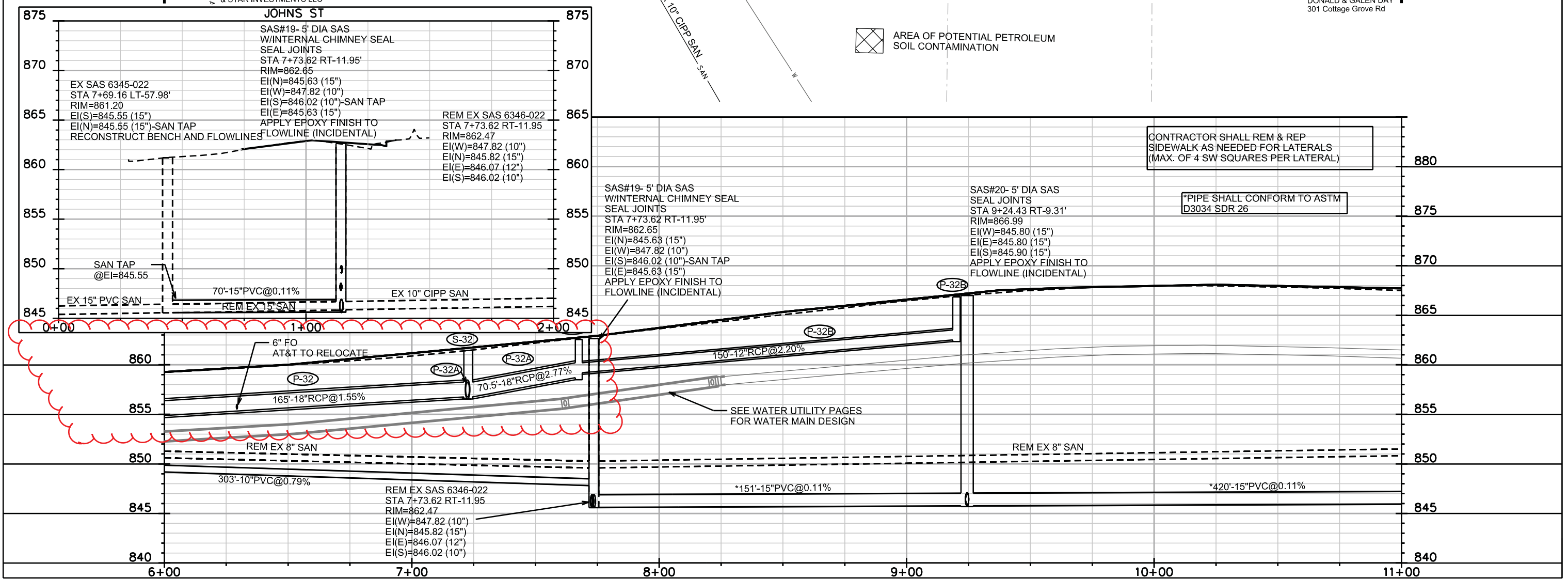
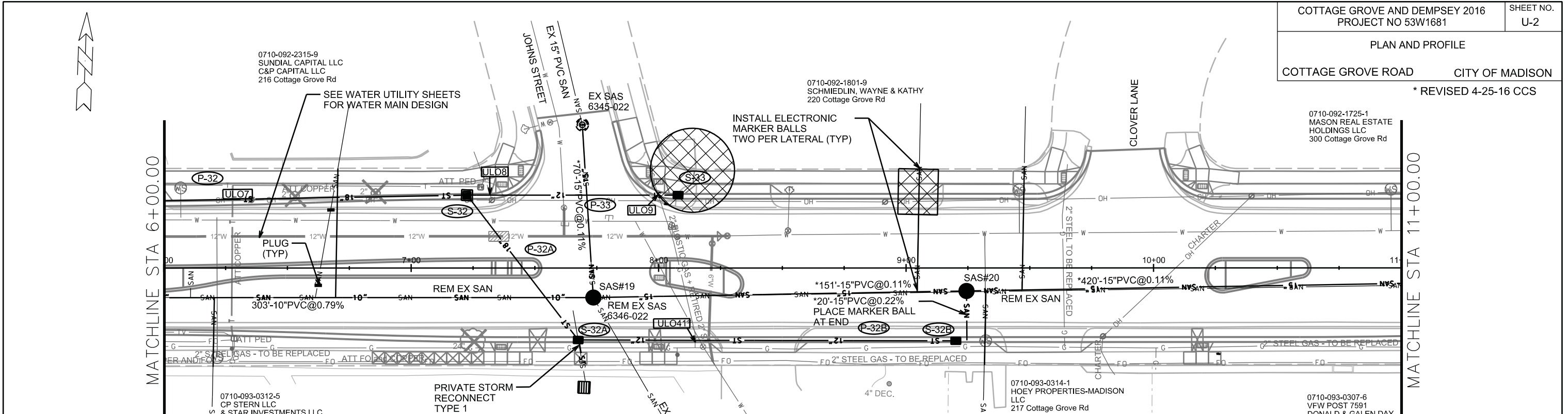

PLOT SCALE: _____

REV. DATE: _____

ORIGINATOR: CITY OF MADISON, STREETS DIVISION

0710-092-2703-6
RDC DEVELOPMENT LLC
516 Cottage Grove Rd

0710-092-2702-8
RDC DEVELOPMENT LLC
530 Cottage Grove Rd

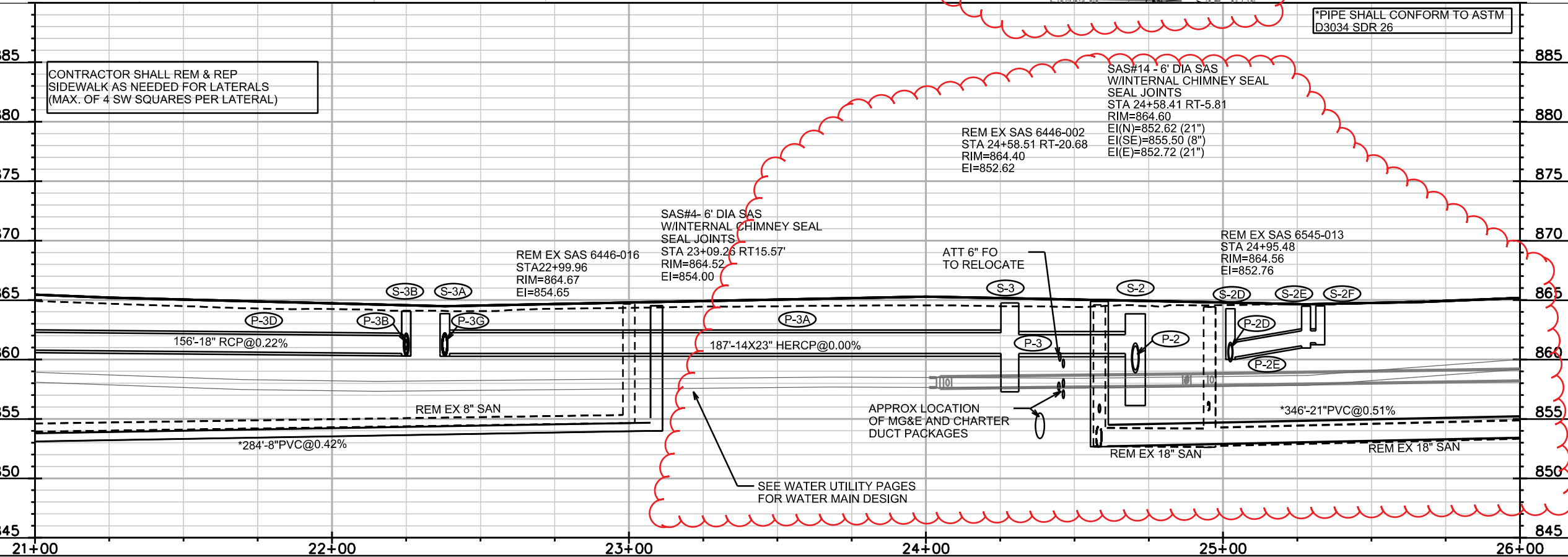
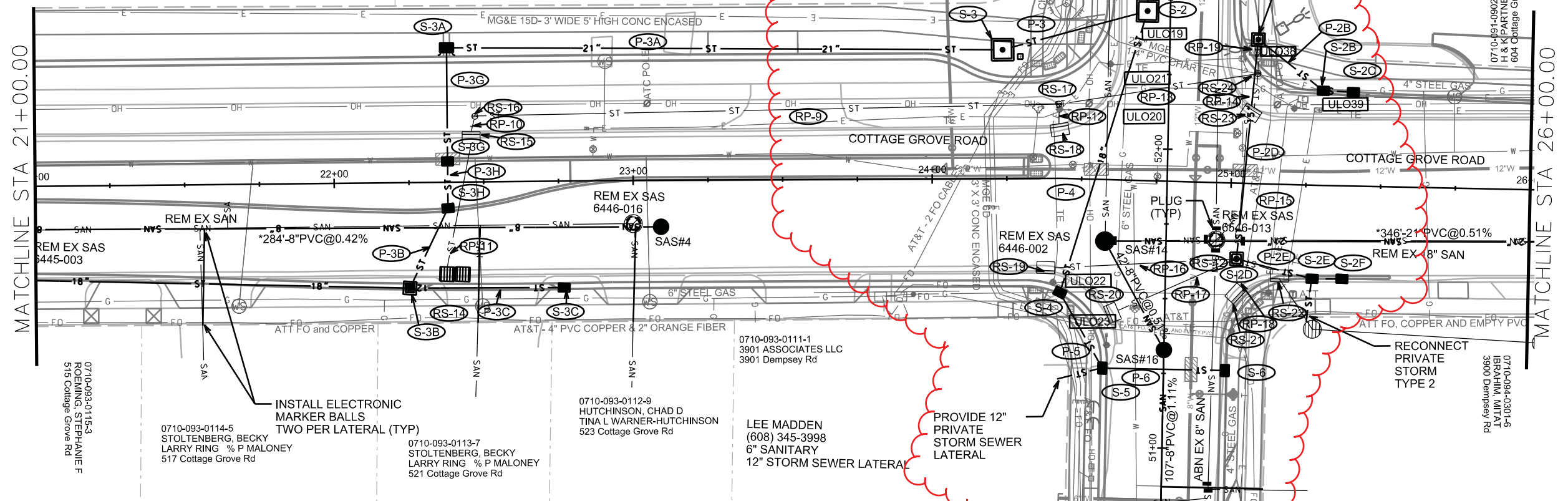

CONTRACTOR SHALL REM & REP
SIDEWALK AS NEEDED FOR LATERALS
(MAX. OF 4 SW SQUARES PER LATERAL)

PIPE SHALL CONFORM TO ASTM
D3034 SDR 26

SEE WATER UTILITY PAGES
FOR WATER MAIN DESIGN

PLOT SCALE: _____
REV. DATE: _____
ORIGINATOR: CITY OF MADISON, STREETS DIVISION

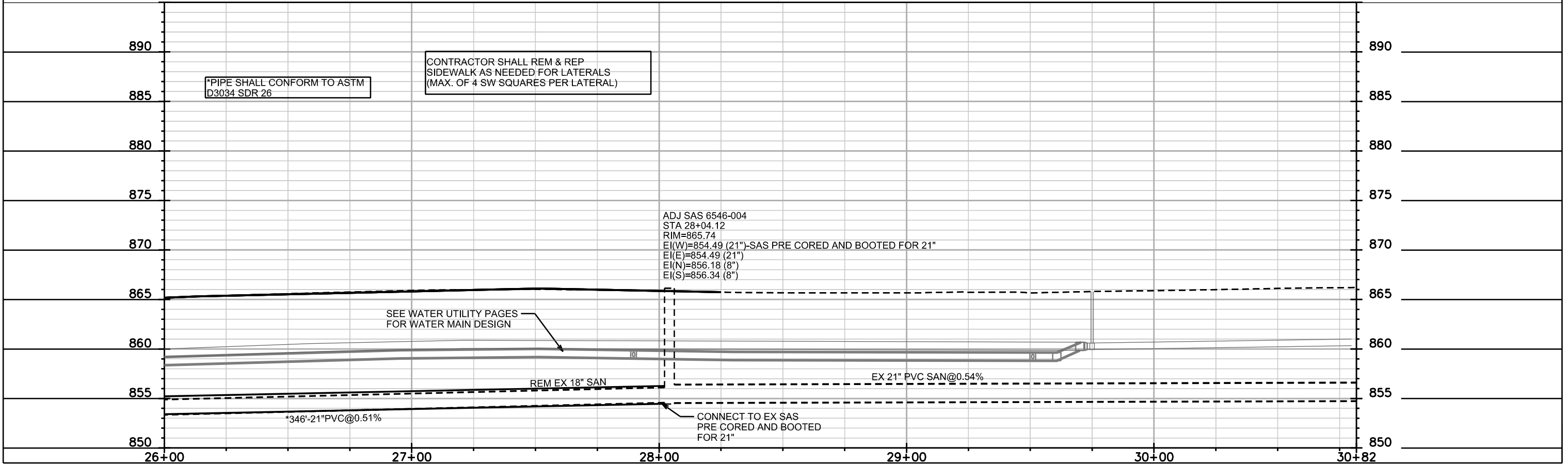
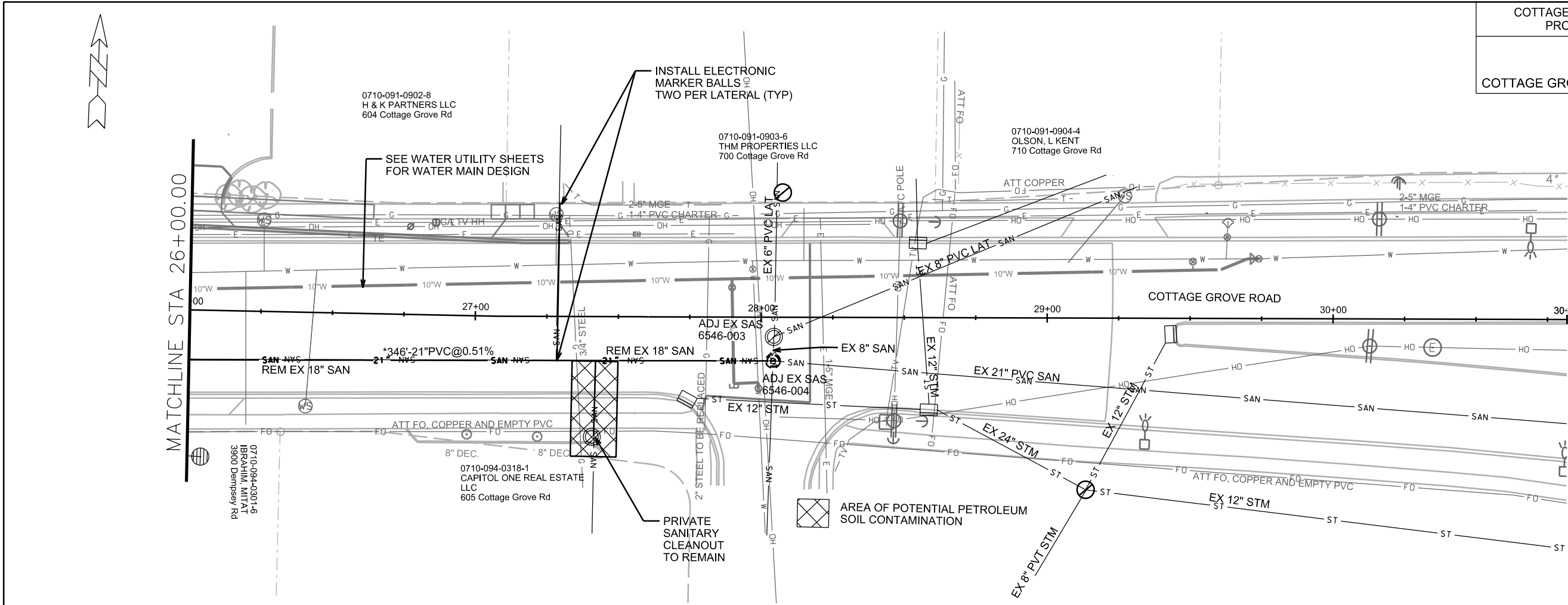

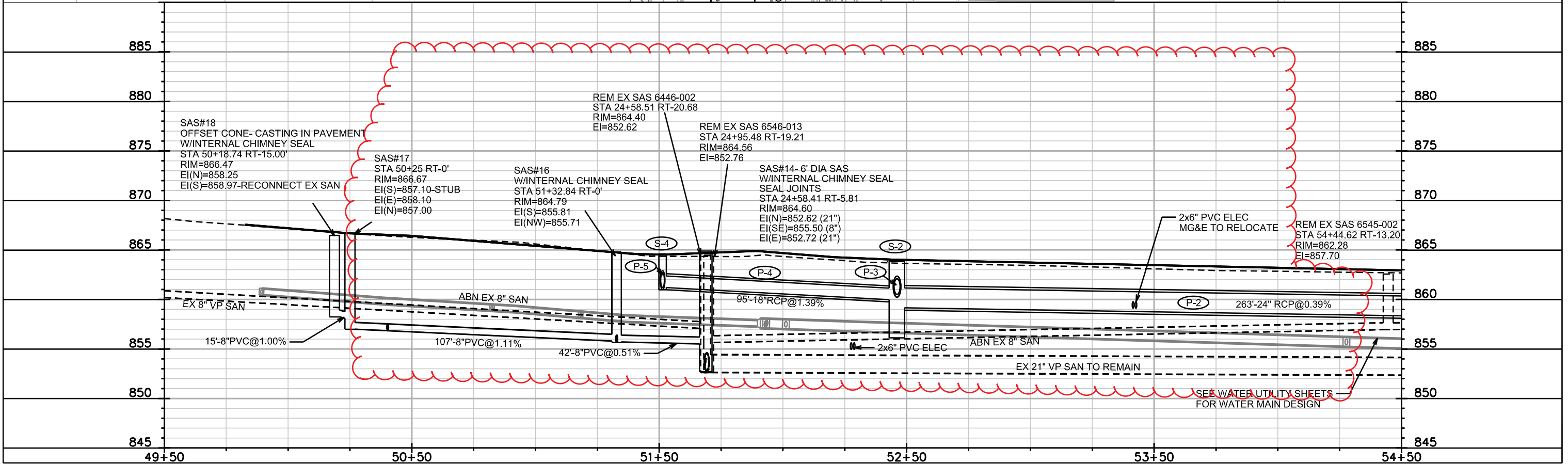
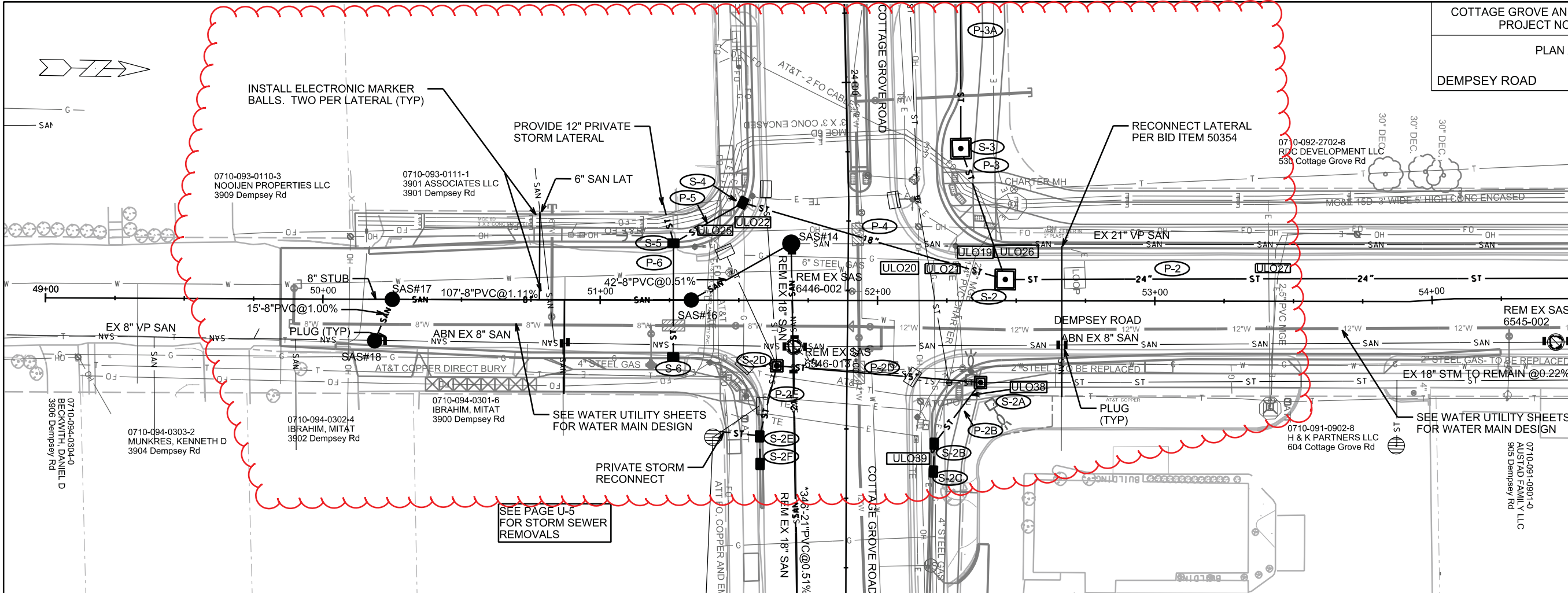

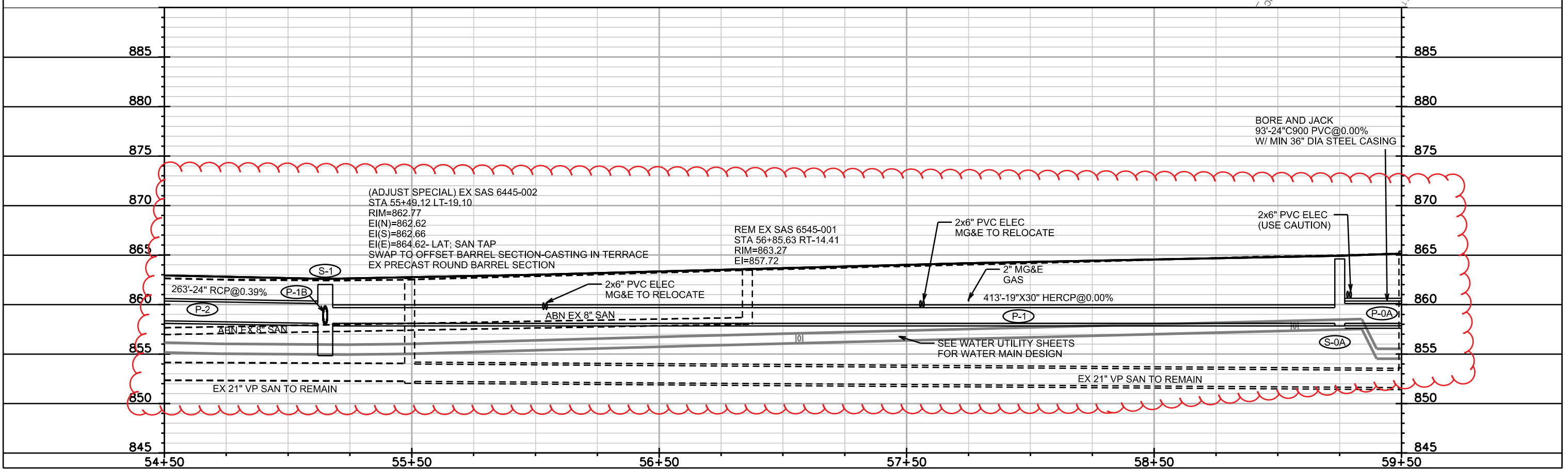
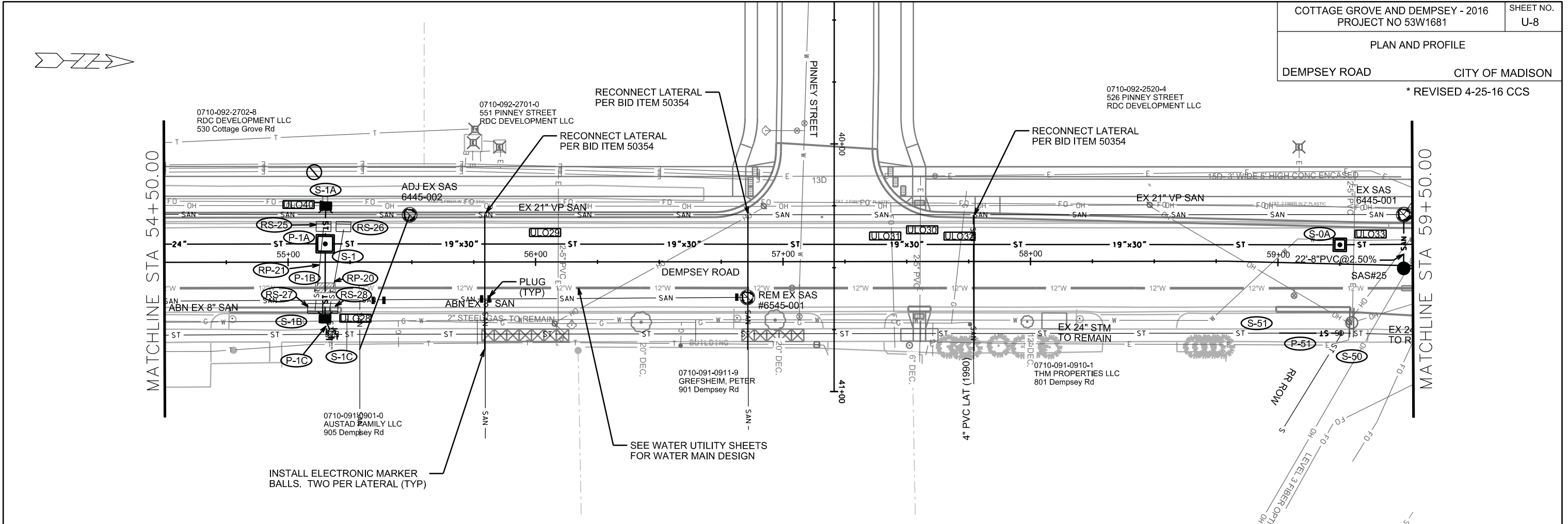

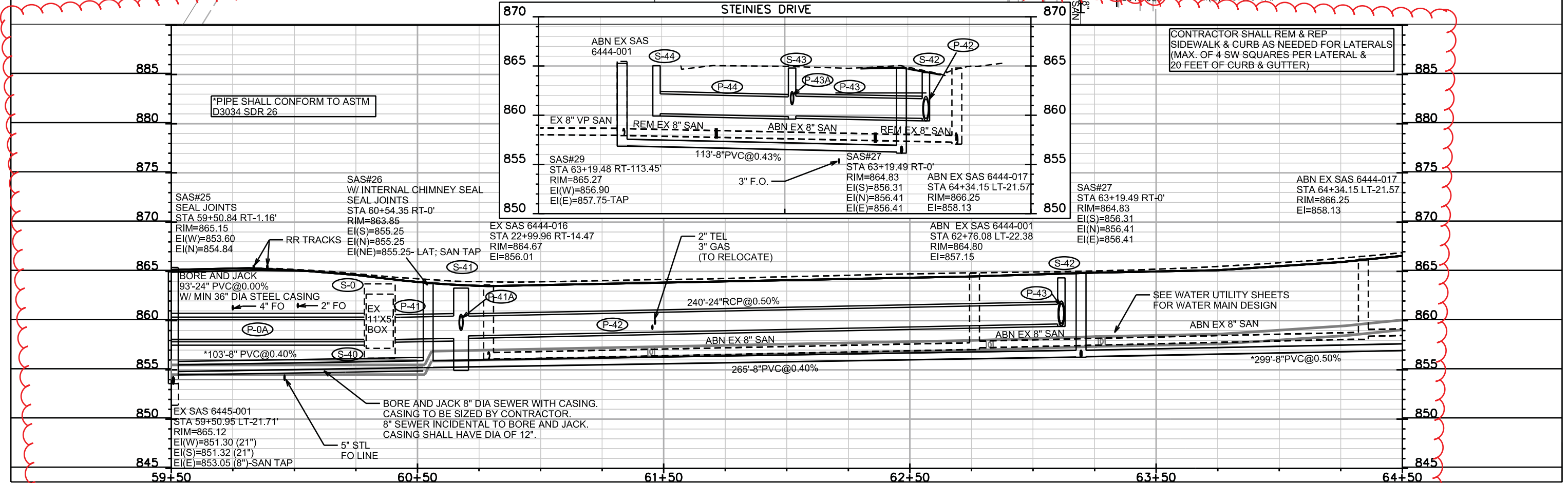
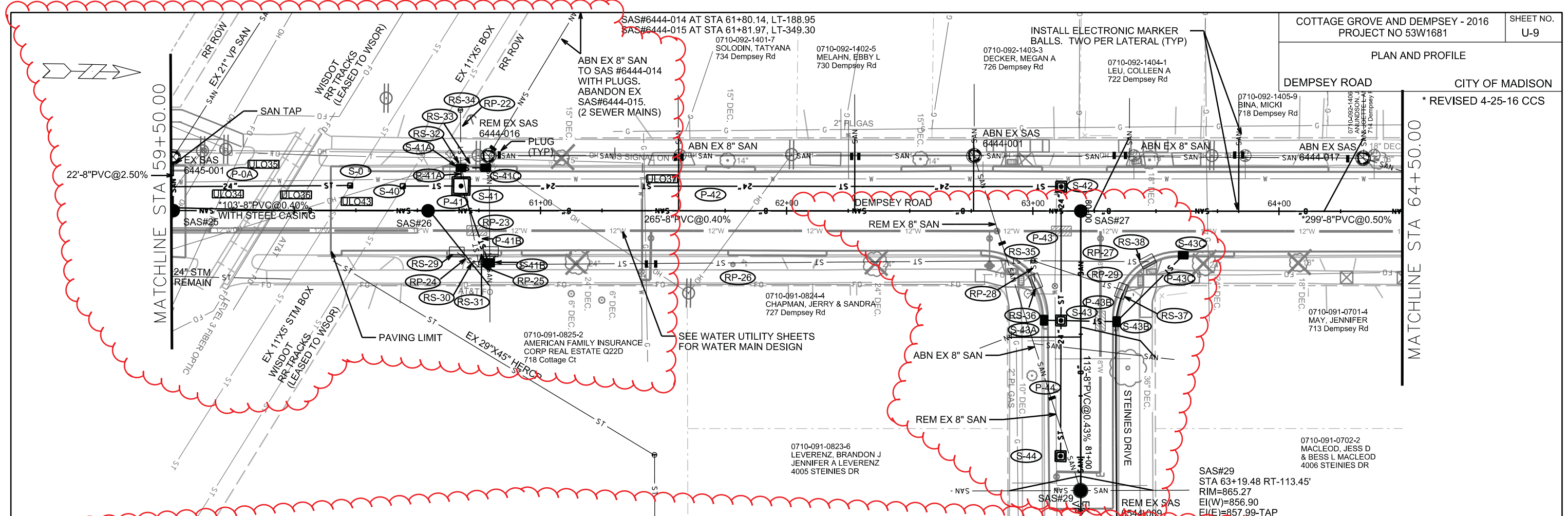

CONTRACTOR SHALL REM & REP
SIDEWALK & CURB AS NEEDED FOR LATERALS
(MAX. OF 4 SW SQUARES PER LATERAL &
20 FEET OF CURB & GUTTER)

*PIPE SHALL CONFORM TO ASTM
D3034 SDR 26

BORE AND JACK
93'-24" PVC@0.00%
W/ MIN 36" DIA STEEL CASING
W/ MIN 36" DIA STEEL CASING
W/ MIN 36" DIA STEEL CASING
W/ MIN 36" DIA STEEL CASING

BORE AND JACK 8" DIA SEWER WITH CASING.
CASING TO BE SIZED BY CONTRACTOR.
8" SEWER INCIDENTAL TO BORE AND JACK.
CASING SHALL HAVE DIA OF 12".

PLAN AND PROFILE
DEMPSEY ROAD CITY OF MADISON

* REVISED 4-25-16 CCS

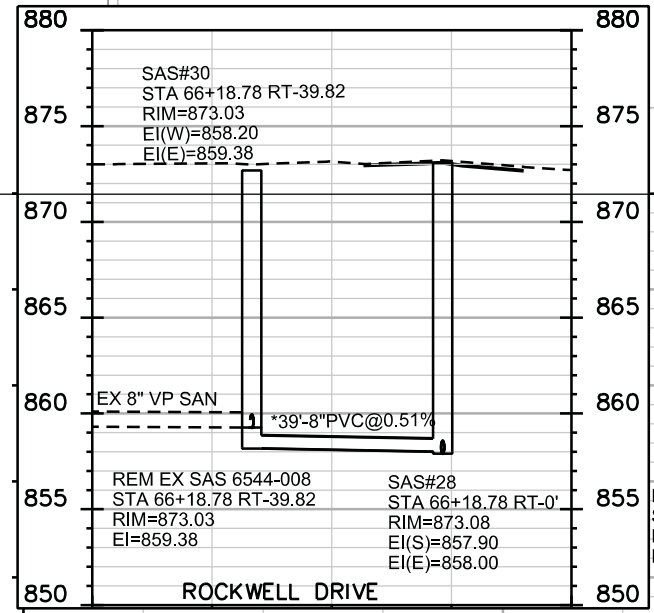
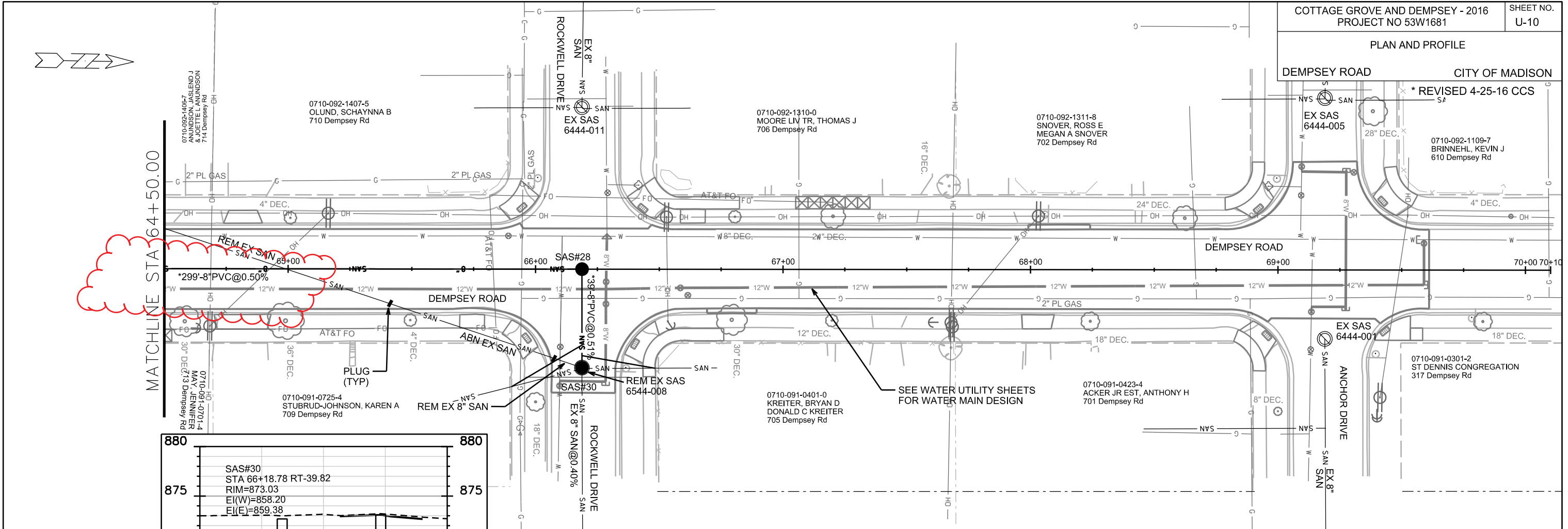

CONTRACTOR SHALL REM & REP SIDEWALK & CURB AS NEEDED FOR LATERALS (MAX. OF 4 SW SQUARES PER LATERAL & 20 FEET OF CURB & GUTTER)

SEE WATER UTILITY SHEETS FOR WATER MAIN DESIGN

PIPE SHALL CONFORM TO ASTM D3034 SDR 26

PLOT SCALE: _____

PLOT NAME: _____

REV. DATE: _____

ORIGINATOR: CITY OF MADISON, STREETS DIVISION

SANITARY SEWER SCHEDULE

PROPOSED SANITARY STRUCTURES

| SAS NO. | STATION | LOCATION (OFFSET) | TOP OF CASTING | E.I. | DEPTH | NOTES |
|-------------------------|----------|-------------------|----------------|---------------|-------------|----------------------------------------------------|
| COTTAGE GROVE RD | | | | | | |
| SAS #1 | 4+70.30 | RT-12.03 | 858.21 | 850.20 | 8.01 | W/INTERNAL CHIMNEY SEAL; SEAL JOINTS |
| SAS #2 | 13+43.72 | RT-9.45 | 863.81 | 846.25 | 17.56 | W/INTERNAL CHIMNEY SEAL; SEAL JOINTS; 5' DIA SAS |
| SAS #3 | 17+24.67 | RT-17.45 | 865.50 | 851.32 | 14.18 | W/INTERNAL CHIMNEY SEAL; SEAL JOINTS; OUTSIDE DROP |
| SAS #4 | 23+09.26 | RT-15.57 | 864.52 | 854.00 | 10.52 | W/INTERNAL CHIMNEY SEAL; SEAL JOINTS |
| SAS #5 | 20+24.88 | RT-14.21 | 865.92 | 852.70 | 13.22 | W/INTERNAL CHIMNEY SEAL; SEAL JOINTS |
| SAS #10 | 13+39.81 | RT-61.19 | 863.72 | 846.31 | 17.41 | W/INTERNAL CHIMNEY SEAL; SEAL JOINTS |
| SAS #11 | 17+23.10 | RT-67.60 | 866.00 | 855.69 | 10.31 | (2);W/INTERNAL CHIMNEY SEAL; OUTSIDE DROP |
| SAS #14 | 24+58.41 | RT-5.81 | 864.60 | 852.62 | 11.98 | (1);W/INTERNAL CHIMNEY SEAL; SEAL JOINTS; 6' DIA |
| SAS #19 | 7+73.62 | RT-11.95 | 862.65 | 845.63 | 17.02 | W/INTERNAL CHIMNEY SEAL; SEAL JOINTS; 5' DIA SAS |
| SAS #20 | 9+24.43 | RT-9.31 | 866.99 | 845.80 | 21.19 | SEAL JOINTS; 5' DIA SAS |
| DEMPSEY RD | | | | | | |
| SAS #25 | 59+50.84 | RT-1.16 | 865.15 | 853.60 | 11.55 | SEAL JOINTS |
| SAS #26 | 60+54.35 | RT-0' | 863.85 | 855.25 | 8.60 | W/INTERNAL CHIMNEY SEAL; SEAL JOINTS |
| SAS #27 | 63+19.49 | RT-0' | 864.83 | 856.31 | 8.52 | |
| SAS #28 | 66+18.78 | RT-0' | 873.08 | 857.90 | 15.18 | |
| SAS #29 | 63+19.49 | RT-113.45 | 865.27 | 856.90 | 8.37 | (4) |
| SAS #30 | 66+18.78 | RT-39.82 | 873.03 | 858.20 | 14.83 | (3) |
| SAS #16 | 51+32.84 | RT-0' | 864.79 | 855.71 | 9.08 | W/INTERNAL CHIMNEY SEAL |
| SAS #17 | 50+25.00 | RT-0' | 866.67 | 857.00 | 9.67 | |
| SAS #18 | 50+18.74 | RT-15.00 | 866.47 | 858.25 | 8.22 | (5); (6); W/INTERNAL CHIMNEY SEAL |

SANITARY STRUCTURE REMOVALS AND ABANDONMENTS

| SAS NO. | STATION | LOCATION (OFFSET) | EX TOP CASTING | EX EI | DEPTH | NOTES |
|----------|----------|-------------------|----------------|--------|-------|---------|
| 6346-002 | 51+62.35 | RT-.80 | 853.43 | 839.08 | 14.35 | REMOVE |
| 6345-001 | 11+07.46 | RT-6.99 | 867.50 | 850.85 | 16.65 | REMOVE |
| 6446-001 | 13+33.41 | RT-8.64 | 863.49 | 851.63 | 11.86 | REMOVE |
| 6445-004 | 17+24.67 | RT-17.45 | 865.50 | 852.97 | 12.53 | REMOVE |
| 6445-003 | 20+94.81 | RT-14.68 | 865.37 | 853.92 | 11.45 | REMOVE |
| 6446-016 | 22+99.96 | RT-14.47 | 864.67 | 856.01 | 8.66 | REMOVE |
| 6446-002 | 24+58.51 | RT-20.68 | 864.40 | 852.62 | 11.78 | REMOVE |
| 6546-013 | 24+95.48 | RT-19.21 | 864.56 | 852.76 | 11.80 | REMOVE |
| 6545-002 | 54+44.62 | RT-15.70 | 862.28 | 857.70 | 4.58 | REMOVE |
| 6545-001 | 56+85.63 | RT-14.41 | 863.27 | 857.72 | 5.55 | REMOVE |
| 6444-016 | 60+78.88 | LT-22.15 | 863.64 | 856.01 | 7.63 | REMOVE |
| 6444-001 | 62+76.23 | LT-22.48 | 864.80 | 857.15 | 7.65 | ABANDON |
| 6544-009 | 63+19.49 | RT-113.45 | 865.47 | 857.97 | 7.50 | REMOVE |
| 6444-017 | 64+34.15 | LT-21.57 | 866.25 | 858.13 | 8.12 | ABANDON |
| 6544-008 | 66+18.78 | RT-39.82 | 873.03 | 859.38 | 13.65 | REMOVE |
| 6346-022 | 7+73.62 | RT-11.95 | 862.49 | 845.84 | 16.65 | REMOVE |
| 6444-015 | 61+79.73 | LT-189.21 | 862.00 | 855.57 | 6.43 | ABANDON |

SANITARY STRUCTURE ADJUSTMENTS

| SAS NO. | STATION | LOCATION (OFFSET) | EX TOP CASTING | PROP TOC | ADJUST AMOUNT (IN) | AVAILABLE ADJUSTMENT (IN) | STRUCTURE TYPE |
|----------|----------|-------------------|----------------|----------|--------------------|---------------------------|----------------|
| 6546-003 | 28+04.40 | RT-6.89 | 865.98 | 865.98 | 0.00 | 4 | PRECAST ROUND |
| 6546-004 | 28+04.12 | RT-15.32 | 865.74 | 865.74 | 0.00 | 1 | PRECAST ROUND |
| 6445-002 | 55+49.12 | LT-19.10 | 862.35 | 862.77 | 0.42 | 10 | PRECAST ROUND |

SPECIFIC NOTES

- STRUCTURE SHALL BE 5' DIA
- RECONNECT EX SAN AT EI=860.08
- RECONNECT EX SAN AT EI=859.38
- RECONNECT EX SAN AT EI=857.99
- RECONNECT EX SAN AT EI=858.97
- WITH OFFSET CONE, OFFSET CASTING IN STREET

PROPOSED SANITARY PIPES

| FROM SAS (DNSTM) | TO SAS (UPSTM) | LGTH (FT) | DISCH. E.I. | INLET E.I. | SLOPE (%) | SIZE (DIA) | * REVISED 4-25-16 CCS TYPE | NOTES |
|------------------|----------------|-----------|---------------|---------------|--------------|------------|----------------------------|-----------------------------|
| SAS #19 | SAS #1 | 303 | 847.82 | 850.20 | 0.79% | 10" | SDR 35 | TAP; RECONSTRUCT BENCH & FL |
| SAS #1 | 6346-020 | 297 | 850.30 | 852.63 | 0.78% | 10" | SDR 35 | CONNECT TO EX STUB |
| SAS #20 | SAS #2 | 420 | 845.80 | 846.25 | 0.11% | 15" | SDR 26 | |
| SAS #2 | SAS #3 | 380 | 846.83 | 851.32 | 1.18% | 8" | SDR 26 | |
| SAS #3 | SAS #5 | 300 | 851.42 | 852.70 | 0.43% | 8" | SDR 26 | |
| SAS #5 | SAS #4 | 284 | 852.80 | 854.00 | 0.42% | 8" | SDR 26 | |
| SAS #2 | SAS #10 | 52 | 846.25 | 846.31 | 0.11% | 15" | SDR 26 | |
| SAS #3 | SAS #11 | 49 | 855.00 | 855.69 | 1.41% | 8" | SDR 26 | |
| SAS #14 | 6546-004 | 346 | 852.72 | 854.49 | 0.51% | 21" | SDR 26 | TAP; RECONSTRUCT BENCH & FL |
| SAS #14 | SAS #16 | 42 | 855.50 | 855.71 | 0.51% | 8" | SDR 35 | CONSTRUCT OUTSIDE DROP |
| 6445-001 | SAS #25 | 22 | 853.05 | 853.60 | 2.50% | 8" | SDR 26 | |
| SAS #25 | SAS #26 | 103 | 854.84 | 855.25 | 0.40% | 8" | SDR 26 | |
| SAS #26 | SAS #27 | 265 | 855.25 | 856.31 | 0.40% | 8" | SDR 35 | |
| SAS #27 | SAS #28 | 299 | 856.41 | 857.90 | 0.50% | 8" | SDR 26 | |
| SAS #27 | SAS #29 | 113 | 856.41 | 856.90 | 0.43% | 8" | SDR 26 | |
| SAS #28 | SAS #30 | 39 | 858.00 | 858.20 | 0.51% | 8" | SDR 26 | |
| SAS #16 | SAS #17 | 107 | 855.81 | 857.00 | 1.11% | 8" | SDR 35 | |
| SAS #17 | SAS #18 | 15 | 858.10 | 858.25 | 1.00% | 8" | SDR 35 | |
| 6345-022 | SAS #19 | 70 | 845.55 | 845.63 | 0.11% | 15" | SDR 26 | |
| SAS #19 | SAS #20 | 151 | 845.63 | 845.80 | 0.11% | 15" | SDR 26 | |
| SAS #20 | PLUG | 20 | 845.90 | 845.94 | 0.22% | 15" | SDR 26 | PLACE MARKER BALL OVER PIPE |

SANITARY PIPE REMOVALS AND ABANDONMENTS

| REMOVE FROM | REMOVE TO | LENGTH (FT) | PAID (Y/N) | SIZE (DIA) | NOTES |
|-------------|-----------|-------------|------------|------------|--------------------------------------|
| 6346-020 | 6346-002 | 278 | N | 8" | REMOVE |
| 6346-002 | 6346-022 | 323 | N | 8" | REMOVE |
| 6346-022 | 6345-001 | 333 | N | 8" | REMOVE |
| 6345-001 | 6446-001 | 226 | N | 8" | REMOVE |
| 6446-001 | 6445-004 | 390 | N | 8" | REMOVE |
| 6445-004 | 6445-003 | 371 | N | 8" | REMOVE |
| 6445-003 | 6446-016 | 205 | N | 8" | REMOVE |
| 6444-016 | 6444-001 | 196 | N | 8" | ABANDON WITH PLUGS |
| 6444-001 | 6444-017 | 158 | N | 8" | ABANDON WITH PLUGS |
| 6444-017 | 6544-008 | 193 | Y/N | 8" | REMOVE PIPE UNDER ROADWAY, 106' PAID |
| 6544-009 | 6444-001 | 141 | Y/N | 8" | REMOVE PIPE UNDER ROADWAY, 70' PAID |
| 6546-013 | 6545-002 | 274 | Y | 8" | ABANDON WITH SLURRY |
| 6545-002 | 6545-001 | 242 | Y | 8" | ABANDON WITH SLURRY |
| SAS#16 | 6546-013 | 146 | Y | 8" | ABANDON WITH SLURRY |
| 6546-013 | 6546-004 | 346 | N | 18" | REMOVE |
| 6546-013 | 6446-002 | 36 | N | 18" | REMOVE |
| 6446-016 | 6444-015 | 192 | N | 8" | ABANDON WITH PLUGS |
| 6444-015 | 6444-014 | 190 | N | 8" | ABANDON WITH PLUGS |
| 6346-022 | 6345-022 | 70 | N | 10.00 | REMOVE |

STORM SEWER SCHEDULE

| | |
|-------------------------------------|-----------|
| COTTAGE GROVE RD/DEMPSEY RD RECONST | SHEET NO. |
| PROJECT NO. 53W1681 | U-12 |
| STORM SEWER SCHEDULE | |
| CITY OF MADISON | |

PROPOSED STORM STRUCTURES

| STRUC. NO. | STATION | LOCATION (OFFSET) | TYPE | TOP OF CASTING | E.I. | DEPTH | NOTES |
|-------------------------|-----------------|-------------------|------------------------|----------------|---------------|-------------|--------------------------------|
| DEMPSEY RD | | | | | | | |
| S-0 | 60+22.69 | LT-10.04 | STM TAP | --- | 858.10 | --- | STM TAP, ULO. PER 90035 |
| S-0A | 59+24.82 | LT-7.72 | 4X4 SAS | 864.77 | 858.10 | 6.67 | W/R-1550-0054 |
| S-1 | 55+15.00 | LT-7.39 | 6X6 CB | 862.50 | 858.10 | 4.40 | FP;(1);(2); SEE S.D.D. 5.7.4. |
| S-1A | 55+15.21 | LT-23.00 | TERRACE INLET TYPE III | 862.40 | 859.65 | 2.75 | FP ; SEE S.D.D. 5.7.12B |
| S-1B | 55+15.00 | RT-23.28 | TERRACE INLET TYPE III | 862.01 | 859.36 | 2.65 | FP; (1); SEE S.D.D. 5.7.12B |
| S-1C | 55+17.61 | RT-29.09 | EX SAS | 862.01 | 859.36 | 2.65 | STM TAP |
| S-2 | 52+46.08 | LT-7.64 | 6X6 CB | 863.89 | 859.13 | 4.76 | SEE S.D.D. 5.7.4.; (2) |
| S-2A | 52+37.25 | RT-29.54 | 3X3 SAS | 864.20 | 860.00 | 4.20 | W/R-1550-0054 |
| S-2B | 52+20.56 | RT-51.64 | H INLET | 864.55 | 861.90 | 2.65 | FP; (1); (6);W/3067-7004-V |
| S-2C | 52+20.29 | RT-61.69 | H INLET | 864.55 | 862.00 | 2.55 | FP; (1); (6);W/3067-7004-V |
| S-2D | 51+63.75 | RT-23.67 | 3X3 SAS | 864.31 | 860.00 | 4.31 | W/R-1550-0054 |
| S-2E | 51+57.60 | RT-49.10 | H INLET | 864.48 | 861.15 | 3.33 | FP; LP; (6);W/3067-7004-V |
| S-2F | 51+57.78 | RT-59.07 | H INLET | 864.58 | 861.47 | 3.11 | FP; (6); W/3067-7004-V |
| S-4 | 51+51.36 | LT-35.14 | H INLET | 864.60 | 861.20 | 3.40 | LP;(1);W/3067-7004-VB |
| S-5 | 51+26.36 | LT-20.50 | H INLET | 864.83 | 862.00 | 2.83 | FP;(1); W/3067-7004-V |
| S-6 | 51+26.37 | RT-20.50 | 3X3 SAS | 864.98 | 862.20 | 2.78 | FP;(1); W/3067-7004-V |
| S-40 | 60+44.04 | LT-9.81 | STM TAP | --- | 858.10 | --- | TAP, ULO |
| S-41 | 60+67.71 | LT-9.90 | 6X6 CB | 863.30 | 858.20 | 5.10 | (2); SEE S.D.D. 5.7.4. |
| S-41A | 60+67.73 | LT-17.25 | H INLET | 862.80 | 859.24 | 3.56 | W/3067-7004-V |
| S-41B | 60+79.00 | RT-21.24 | TERRACE INLET TYPE III | 863.37 | 859.60 | 3.77 | SEE S.D.D. 5.7.12B |
| S-41C | 60+77.74 | LT-17.30 | H INLET | 862.76 | 859.56 | 3.20 | W/3067-7004-V |
| S-42 | 63+11.49 | LT-9.90 | 4X4 SAS | 864.34 | 859.66 | 4.68 | W/R-1550-0054 |
| S-43 | 63+11.49 | RT-44.45 | 4X4 SAS | 864.56 | 860.00 | 4.56 | W/R-1550-0054-OPEN |
| S-43A | 63+04.63 | RT-44.32 | H INLET | 864.59 | 861.42 | 3.17 | LP;W/3067-7004-VB |
| S-43B | 63+34.09 | RT-44.87 | H INLET | 864.89 | 861.43 | 3.46 | LP;W/3067-7004-VB |
| S-43C | 63+61.09 | RT-17.91 | H INLET | 864.96 | 861.70 | 3.26 | LP;W/3067-7004-VB |
| S-44 | 63+11.37 | RT-99.50 | 4X4 SAS | 865.04 | 860.26 | 4.78 | W/R-1550-0054; (5) |
| COTTAGE GROVE RD | | | | | | | |
| S-3 | 24+23.76 | LT-43.09 | 6X6 CB | 864.83 | 860.50 | 4.33 | FP; (2); SEE S.D.D. 5.7.4. |
| S-3A | 22+38.01 | LT-45.00 | TERRACE INLET TYPE III | 863.85 | 860.50 | 3.35 | LP; FP; S.D.D. 5.7.12B |
| S-3B | 22+25.00 | RT-35.25 | 3X3 SAS | 864.06 | 860.50 | 3.56 | LP; FP;W/3067-7004-VB |
| S-3C | 22+76.55 | RT-35.64 | H INLET | 864.36 | 861.26 | 3.10 | LP; FP;W/3067-7004-VB |
| S-3D | 20+66.42 | RT-30.60 | H INLET | 865.58 | 860.85 | 4.73 | FP; W/3067-7004 |
| S-3G | 22+38.01 | LT-7.00 | H INLET | 864.76 | 860.50 | 4.26 | LP; FP;W/3067-7004-VB; (6) |
| S-3H | 22+38.01 | RT-8.66 | H INLET | 864.73 | 860.50 | 4.23 | LP; FP;W/3067-7004-VB; (6) |
| S-10 | 17+71.21 | LT-35.14 | EX SAS | 865.79 | 861.29 | 4.50 | TAP; EX BOX OUT |
| S-10A | 18+07.46 | LT-43.50 | H INLET | 865.80 | 862.60 | 3.20 | W/3067-7004-V |
| S-11 | 17+66.69 | RT-1.00 | H INLET | 866.50 | 863.15 | 3.35 | W/3067-7004-V; (6) |
| S-11A | 17+66.69 | RT-9.00 | H INLET | 866.30 | 863.10 | 3.20 | W/3067-7004-V; (6) |
| S-11B | 17+73.93 | RT-35.50 | H INLET | 865.79 | 862.48 | 3.31 | FP; (1); W/3067-7004-V |
| S-12 | 17+41.76 | RT-38.63 | H INLET | 865.56 | 862.60 | 2.96 | LP; FP; (1); W/3067-7004-VB |
| S-13 | 17+28.53 | RT-62.04 | H INLET | 865.84 | 862.70 | 3.14 | FP; (4); W/3067-7004-V |
| S-14 | 16+97.73 | RT-62.85 | H INLET | 865.90 | 862.85 | 3.05 | FP; W/3067-7004-V |

PROPOSED STORM PIPES

| PIPE NO. | FROM (DNSTM) | TO (UPSTM) | PLAN LGTH (FT) | PIPE LGTH (FT) | DISCH. E.I. | INLET E.I. | SLOPE (%) | PIPE SIZE | TYPE | NOTES |
|----------|--------------|------------|----------------|----------------|---------------|---------------|--------------|----------------|--------------|---------|
| P-0A | S-0 | S-0A | 97 | 95.5 | 858.10 | 858.10 | 0.00% | 24" | STM PIPE | STM TAP |
| P-1 | S-0A | S-1 | 410 | 405.0 | 858.10 | 858.10 | 0.00% | 19"x30" | HERCP | |
| P-1A | S-1 | S-1A | 15 | 11.5 | 858.60 | 859.65 | 9.13% | 18" | RCP | |
| P-1B | S-1 | S-1B | 30 | 26.5 | 858.60 | 859.36 | 2.87% | 18" | RCP | |
| P-1C | S-1C | S-1B | 7 | 4.0 | 859.36 | 859.36 | 0.00% | 14"x23" | HERCP | STM TAP |
| P-2 | S-1 | S-2 | 269 | 263.0 | 858.10 | 859.13 | 0.39% | 24" | RCP | |
| P-2B | S-3H | S-2B | 28 | 24.2 | 861.00 | 861.90 | 3.72% | 15" | RCP | |
| P-2C | S-2B | S-2C | 10 | 7.0 | 861.90 | 862.00 | 1.43% | 12" | RCP | |
| P-2D | S-2A | S-2D | 74 | 70.5 | 860.00 | 860.00 | 0.00% | 15" | RCP | |
| P-2E | S-2D | S-2E | 26 | 23.0 | 860.19 | 861.15 | 4.17% | 15" | RCP | |
| P-2F | S-2E | S-2F | 10 | 7.0 | 861.40 | 861.47 | 1.00% | 12" | RCP | |
| P-3 | S-2 | S-3 | 50 | 44.0 | 860.50 | 860.50 | 0.00% | 19"x30" | HERCP | |
| P-3A | S-3 | S-3A | 187 | 184.0 | 860.50 | 860.50 | 0.00% | 14"x23" | HERCP | |
| P-3B | S-3A | S-3B | 29 | 27.0 | 860.50 | 860.50 | 0.00% | 18" | RCP | |
| P-3C | S-3B | S-3C | 51 | 48.5 | 861.00 | 861.26 | 0.54% | 12" | RCP | |
| P-3D | S-3B | S-3D | 159 | 156.0 | 860.50 | 860.85 | 0.22% | 18" | RCP | |
| P-3G | S-3A | S-3G | 38 | 36.0 | 860.50 | 860.50 | 0.00% | 18" | RCP | |
| P-3H | S-3G | S-3H | 16 | 14.0 | 860.50 | 860.50 | 0.00% | 18" | RCP | |
| P-4 | S-2 | S-4 | 99 | 95.0 | 859.88 | 861.20 | 1.39% | 18" | RCP | |
| P-5 | S-4 | S-5 | 29 | 25.5 | 862.00 | 862.00 | 0.00% | 14"X23" | HERCP | |
| P-6 | S-5 | S-6 | 41 | 38.5 | 862.00 | 862.20 | 0.52% | 15" | RCP | |
| P-10A | S-10 | S-10A | 37 | 33.5 | 861.29 | 862.60 | 3.91% | 12" | RCP | TAP |
| P-11 | S-3D | S-11B | 292 | 289.0 | 861.20 | 862.48 | 0.44% | 18" | RCP | TAP |
| P-11A | S-11A | S-11 | 8 | 6.0 | 863.10 | 863.15 | 0.83% | 12" | RCP | |
| P-11B | S-11B | S-11A | 27 | 7.0 | 862.98 | 863.10 | 1.71% | 12" | RCP | |
| P-12 | S-11B | S-12 | 32 | 29.0 | 862.48 | 862.60 | 0.41% | 15" | RCP | NCM |
| P-13 | S-12 | S-13 | 27 | 23.0 | 862.60 | 862.70 | 0.43% | 15" | RCP | NCM |
| P-14 | S-13 | S-14 | 31 | 28.5 | 862.70 | 862.85 | 0.53% | 12" | RCP | |
| P-41 | S-40 | S-41 | 23 | 20.0 | 858.10 | 858.20 | 0.50% | 27" | RCP | TAP |
| P-41A | S-41 | S-41A | 7 | 3.5 | 859.20 | 859.24 | 1.14% | 15" | RCP | |
| P-41B | S-41 | S-41B | 33 | 29.0 | 858.95 | 859.60 | 2.24% | 18" | RCP | |
| P-41C | S-41A | S-41C | 10 | 7.0 | 859.49 | 859.56 | 1.00% | 12" | RCP | |
| P-42 | S-41 | S-42 | 243 | 239.0 | 858.45 | 859.66 | 0.51% | 24" | RCP | |
| P-43 | S-42 | S-43 | 55 | 51.5 | 859.66 | 860.00 | 0.66% | 24" | RCP | |
| P-43A | S-43 | S-43A | 7 | 4.5 | 861.30 | 861.42 | 2.67% | 12" | RCP | NCM |
| P-43B | S-43 | S-43B | 23 | 20.0 | 861.00 | 861.43 | 2.15% | 12" | RCP | |
| P-43C | S-43B | S-43C | 38 | 35.5 | 861.43 | 861.70 | 0.76% | 12" | RCP | |
| P-44 | S-43 | S-44 | 55 | 52.0 | 860.00 | 860.26 | 0.50% | 24" | RCP | |

* REVISED 4-25-16

NOTE: PLAN LENGTH IS FROM CENTER OF STRUCTURE TO CENTER OF STRUCTURE. PIPE LENGTH IS ACTUAL LENGTH OF PIPE FROM STRUCTURE WALL TO STRUCTURE WALL. SLOPE CALCULATED USING PIPE LENGTH.

STANDARD NOTES:

- ABBREVIATIONS: AE = APRON ENDWALL; RCP = REINFORCED CONCRETE PIPE; HERCP = HORIZONTAL ELLIPTICAL REINFORCED CONCRETE PIPE; DNA = DOES NOT APPLY; SAS = SEWER ACCESS STRUCTURE; LP = LOW POINT INLET STRUCTURE; FP = FIELD POURED STRUCTURE; TR = TOP OF CONCRETE ROOF; NCM = NO CROWN MATCH FOR PIPES; UD = UNDERDRAIN

- APPROXIMATE DISCHARGE E.I. GIVEN, ADJUST E.I. AND PIPE SLOPE IN THE FIELD.

- TOP OF CASTING GRADE GIVEN IS THE TOP OF CURB FOR INLET STRUCTURES AND THE FLOWLINE OF THE CLOSED CASTING FOR SAS's.

- TOP OF CONCRETE ROOF (TR) IS 1.25' BELOW TOP OF CASTING UNLESS OTHERWISE NOTED.

- ALL REINFORCED CONCRETE PIPES TO BE CLASS III UNLESS OTHERWISE NOTED.

- SURVEYOR TO CONFIRM THAT ALL INLET STATION / OFFSETS LINE UP WITH PROPOSED CURB AND GUTTER.

- ALL STRUCTURES CALLED OUT AS FIELD POURED SHALL BE FIELD POURED. ALL OTHER STRUCTURES (NOT INDICATED AS FIELD POURED) SHALL BE SUBMITTED TO CITY ENGINEERING FOR APPROVAL IF PRECAST STRUCTURES ARE PREFERRED. CONTACT COREY OF CITY ENGINEERING AT (608) 266-9721 FOR PRECAST APPROVALS. FAX SHOP DRAWINGS TO (608)264-9275, OR EMAIL SHOP DRAWINGS TO CSTELLJES@CITYOFMADISON.COM.

SPECIFIC NOTES

- STRUCTURE DEPTH MAY REQUIRE PIPE WALLS BE POURED INTEGRAL TO STRUCTURE ROOF
- W/ 3' SUMP BELOW LISTED INVERT; STRUCTURE SHALL HAVE 2 CASTINGS
- PROVIDE 15" KNOCKOUT TO SOUTH FOR FUTURE STORM
- PROVIDE 24" KNOCKOUT TO EAST FOR FUTURE STORM
- WARP CURB FACE PER S.D.D. 5.7.27 FOR 1'-1' CURB
- TOP OF CASTING LISTED PER S.D.D. 5.7.12B

STORM SEWER SCHEDULE

| | |
|------------------------------------------------------------|-------------------|
| COTTAGE GROVE RD/DEMPSEY RD RECONST PROJECT NO. 53W1681 | SHEET NO. U-13 |
| STORM SEWER SCHEDULE | |
| CITY OF MADISON | |

PROPOSED STORM STRUCTURES

| STRUC. NO. | STATION | LOCATION (OFFSET) | TYPE | TOP OF CASTING | E.I. | DEPTH | NOTES |
|-------------------------|----------|-------------------|------------|----------------|---------------|-------------|-------------------------|
| COTTAGE GROVE RD | | | | | | | |
| S-30 | 1+65.11 | LT-32.88 | EX SAS | 861.37 | 850.52 | 10.85 | STM TAP |
| S-30A | 2+06.53 | LT-23.50 | 3X3 SAS | 860.90 | 852.48 | 8.42 | W/R-1550-0054 |
| S-31 | 4+78.00 | LT-23.50 | 6X6 CB | 857.91 | 853.82 | 4.09 | LP; (1); (2) |
| S-31A | 4+78.00 | RT-26.50 | 3X3 SAS | 858.29 | 854.83 | 3.46 | LP; FP; W/3067-7004-VB |
| S-31B | 4+88.00 | RT-26.50 | H INLET | 858.39 | 855.14 | 3.25 | W/3067-7004-V |
| S-31C | 5+53.98 | LT-26.50 | 3X3 SAS | 858.44 | 854.19 | 4.25 | W/3067-7004-V |
| S-31D | 5+53.98 | RT-0' | H INLET | 859.22 | 855.72 | 3.50 | W/3067-7004-V |
| S-31E | 5+53.98 | RT-9.00 | H INLET | 859.05 | 855.85 | 3.20 | (6);W/3067-7004-V |
| S-32 | 7+22.50 | LT-29.40 | 3X3 SAS | 861.24 | 856.75 | 4.49 | (6);W/3067-7004-V |
| S-32A | 7+67.51 | RT-29.14 | H INLET | 862.55 | 858.70 | 3.85 | W/3067-7004-V |
| S-32B | 9+20.11 | RT-29.50 | H INLET | 866.84 | 862.50 | 4.34 | W/3067-7004-V |
| S-33 | 8+07.86 | LT-29.50 | H INLET | 863.67 | 860.67 | 3.00 | FP; W/3067-7004-V |
| S-20 | 11+64.39 | LT-25.36 | 3X6 SAS | 866.67 | 857.05 | 9.62 | W/3067-7004-V; (3); (7) |
| S-21 | 13+06.21 | LT-24.23 | 3X6 SAS | 864.12 | 858.10 | 6.02 | (7);W/3067-7004-V |
| S-21A | 14+40.09 | LT-30.10 | 3X3 SAS | 863.34 | 859.34 | 4.00 | LP; FP; W/3067-7004-VB |
| S-21B | 14+40.09 | RT-35.50 | H INLET | 863.23 | 860.03 | 3.20 | LP;W/3067-7004-VB |
| S-21C | 14+40.09 | LT-3.53 | H INLET | 863.89 | 859.51 | 4.38 | LP;W/3067-7004-VB; (6) |
| S-21D | 14+40.09 | RT-9.00 | H INLET | 862.78 | 859.58 | 3.20 | LP;W/3067-7004-VB; (6) |
| S-22 | 13+03.31 | RT-27.43 | 5X5 SAS | 863.93 | 859.90 | 4.03 | LP; FP;W/3067-7004-VB |
| S-22A | 13+66.83 | RT-38.56 | H INLET | 863.46 | 860.26 | 3.20 | LP;W/3067-7004-VB |
| S-23 | 13+29.49 | RT-55.49 | 3X3 SAS | 864.25 | 860.81 | 3.44 | (4); W/3067-7004-V |
| S-24 | 13+57.82 | RT-57.29 | H INLET | 864.02 | 861.02 | 3.00 | FP; LP;W/3067-7004-VB |
| DEMPSEY RD | | | | | | | |
| S-50 | 59+25.76 | RT-26.11 | EX SAS | 864.75 | 858.05 | 6.70 | STM TAP |
| S-51 | 59+00.72 | RT-26.45 | PIPE JOINT | --- | 858.17 | --- | REPLACE TO PIPE JOINT |

PROPOSED STORM PIPES

| PIPE NO. | FROM (DNSTM) | TO (UPSTM) | PLAN LGTH (FT) | PIPE LGTH (FT) | DISCH. E.I. | INLET E.I. | SLOPE (%) | PIPE SIZE | TYPE | NOTES |
|----------|--------------|------------|----------------|----------------|---------------|---------------|--------------|-----------|------|---------|
| P-30 | S-30 | S-30A | 43 | 39.5 | 852.28 | 852.48 | 0.51% | 18" | RCP | |
| P-31 | S-30A | S-31 | 271 | 267.0 | 852.48 | 853.82 | 0.50% | 18" | RCP | STM TAP |
| P-31A | S-31 | S-31A | 52 | 49.0 | 854.07 | 854.83 | 1.55% | 15" | RCP | |
| P-31B | S-31A | S-31B | 10 | 7.0 | 855.08 | 855.14 | 0.86% | 12" | RCP | |
| P-31C | S-31 | S-31C | 76 | 71.5 | 853.82 | 854.19 | 0.52% | 18" | RCP | |
| P-31D | S-31C | S-31D | 26 | 24.0 | 854.69 | 855.72 | 4.29% | 12" | RCP | |
| P-31E | S-31D | S-31E | 9 | 7.0 | 855.72 | 855.85 | 1.86% | 12" | RCP | |
| P-32 | S-31C | S-32 | 168 | 165.5 | 854.19 | 856.75 | 1.55% | 18" | RCP | |
| P-32A | S-32 | S-32A | 74 | 70.5 | 856.75 | 858.70 | 2.77% | 18" | RCP | |
| P-32B | S-32A | S-32B | 153 | 150.0 | 859.20 | 862.50 | 2.20% | 12" | RCP | |
| * P-33 | S-32 | S-33 | 85 | 82.0 | 857.45 | 860.67 | 3.93% | 12" | RCP | |
| P-21 | S-20 | S-21 | 142 | 137.0 | 857.05 | 858.10 | 0.77% | 18" | RCP | |
| P-21A | S-21 | S-21A | 135 | 130.0 | 858.35 | 859.34 | 0.76% | 15" | RCP | |
| P-21B | S-21D | S-21B | 26 | 24.5 | 859.83 | 860.03 | 0.82% | 12" | RCP | |
| P-21C | S-21A | S-21C | 27 | 24.0 | 859.34 | 859.51 | 0.71% | 12" | RCP | |
| P-21D | S-21C | S-21D | 13 | 10.5 | 859.51 | 859.58 | 0.67% | 12" | RCP | |
| P-22 | S-21 | S-22 | 52 | 47.0 | 859.60 | 859.90 | 0.64% | 18" | RCP | NCM |
| P-22A | S-22 | S-22A | 66 | 63.0 | 859.90 | 860.26 | 0.57% | 12" | RCP | |
| * P-23 | S-22 | S-23 | 38 | 34.0 | 860.35 | 860.81 | 1.35% | 15" | RCP | |
| * P-24 | S-23 | S-24 | 31 | 28.5 | 860.81 | 861.02 | 0.74% | 15" | RCP | |
| P-51 | S-50 | S-51 | 25 | 23.0 | 858.10 | 858.17 | 0.31% | 24" | RCP | |

STORM SEWER ULOs

| ULO NO. | STATION | LOCATION (OFFSET) | TYPE | ELEV TOP | ELEV BOTTOM | NOTES |
|-----------|-----------------|-------------------|-----------|----------|-------------|----------------------------------------|
| * ULO-1 | 1+98.00 | LT-25.50 | TE ELEC | N/A | | NO CONFLICT |
| * ULO-2 | 2+38.00 | LT-23.50 | TE ELEC | N/A | | TE TO RE INSTALL |
| * ULO-3 | 2+88.00 | LT-23.50 | TE ELEC | N/A | | TE TO RE INSTALL |
| * ULO-4 | 5+01.00 | LT-23.50 | TEL | 854.62 | 854.37 | IN CONFLICT ATT TO MOVE |
| * ULO-5 | 4+78.00 | RT-15.10 | FO | 854.61 | 853.16 | ATT TO RELOCATE |
| * ULO-6 | 4+80.00 | RT-26.50 | TV | 849.63 | | NO CONFLICT |
| * ULO-7 | 6+28.00 | LT-27.50 | TEL | 856.27 | 855.49 | IN CONFLICT ATT TO MOVE |
| * ULO-8 | 7+32.00 | LT-29.00 | TEL | N/A | | TO BE RELOCATED |
| * ULO-9 | 7+97.00 | LT-27.50 | GAS | 859.90 | 859.73 | STORM SEWER REVISED |
| * ULO-10 | 17+33.00 | RT-55.60 | GAS | 861.98 | | STORM SEWER REVISED |
| * ULO-11 | 13+15.00 | LT-24.88 | GAS&WATER | 860.22 | 857.83 | NO CONFLICT, STM BETWEEN GAS AND WATER |
| * ULO-12 | 13+09.00 | RT-28.00 | GAS | N/A | | GAS TO BE MOVED |
| * ULO-13 | 13+12.00 | RT-36.50 | GAS | N/A | | GAS TO BE MOVED |
| * ULO-14 | 13+17.50 | RT-42.50 | FO | 860.12 | 859.50 | STORM SEWER REVISED |
| * ULO-15 | 13+66.00 | RT-40.00 | GAS | N/A | | GAS TO BE MOVED |
| * ULO-16 | 17+33.00 | RT-48.00 | FO | 863.20 | 862.80 | ATT TO RELOCATE |
| * ULO-17 | 17+39.00 | RT-43.00 | GAS | 861.55 | | STORM SEWER REVISED |
| * ULO-18 | 17+54.00 | RT-37.00 | GAS | 862.09 | | STORM SEWER REVISED |
| * ULO-19 | 24+65.50 | LT-45.00 | MGE ELEC | 855.36 | 854.98 | NO CONFLICT |
| * ULO-19A | 24+36.61 | LT-46.70 | FO | 860.61 | 860.11 | FO TO RELOCATE |
| * ULO-20 | 24+64.00 | LT-31.00 | GAS | N/A | | GAS TO BE MOVED |
| * ULO-21 | 24+63.00 | LT-39.00 | TE ELEC | 855.48 | 854.38 | NO CONFLICT |
| * ULO-22 | 24+46.00 | RT-48.00 | GAS | N/A | | GAS TO BE MOVED |

SPECIFIC NOTES

- OFFSET PIPES 1.75' TOWARDS STREET FROM CENTER. STRUCTURE TO HAVE ONE 3067 (TOC LISTED) AND ONE 1550 CASTING
- W/ 3' SUMP BELOW LISTED INVERT; STRUCTURE SHALL HAVE 2 CASTINGS
- RECONNECT 18" PRIVATE STORM AT EI=861.06
- PROVIDE 15" KNOCKOUT TO SOUTH FOR FUTURE STORM
- WARP CURB FACE PER S.D.D. 5.7.27 FOR 1'-1" CURB
- CENTER OF PIPE STATIONED. STRUCTURE TO HAVE ONE 3067 CASTING (TOC LISTED) IN CURB LINE

STANDARD NOTES:

- NOTE: PLAN LENGTH IS FROM CENTER OF STRUCTURE TO CENTER OF STRUCTURE. PIPE LENGTH IS ACTUAL LENGTH OF PIPE FROM STRUCTURE WALL TO STRUCTURE WALL. SLOPE CALCULATED USING PIPE LENGTH.
- ABBREVIATIONS: AE = APRON ENDWALL; RCP = REINFORCED CONCRETE PIPE; HERCP = HORIZONTAL ELLIPTICAL REINFORCED CONCRETE PIPE; DNA = DOES NOT APPLY; SAS = SEWER ACCESS STRUCTURE; LP = LOW POINT INLET STRUCTURE; FP = FIELD POURED STRUCTURE; TR = TOP OF CONCRETE ROOF; NCM = NO CROWN MATCH FOR PIPES; UD = UNDERDRAIN
 - APPROXIMATE DISCHARGE E.I. GIVEN, ADJUST E.I. AND PIPE SLOPE IN THE FIELD.
 - TOP OF CASTING GRADE GIVEN IS THE TOP OF CURB FOR INLET STRUCTURES AND THE FLOWLINE OF THE CLOSED CASTING FOR SAS's.
 - TOP OF CONCRETE ROOF (TR) IS 1.25' BELOW TOP OF CASTING UNLESS OTHERWISE NOTED.
 - ALL REINFORCED CONCRETE PIPES TO BE CLASS III UNLESS OTHERWISE NOTED.
 - SURVEYOR TO CONFIRM THAT ALL INLET STATION / OFFSETS LINE UP WITH PROPOSED CURB AND GUTTER.
 - ALL STRUCTURES CALLED OUT AS FIELD POURED SHALL BE FIELD POURED. ALL OTHER STRUCTURES (NOT INDICATED AS FIELD POURED) SHALL BE SUBMITTED TO CITY ENGINEERING FOR APPROVAL IF PRECAST STRUCTURES ARE PREFERRED. CONTACT COREY OF CITY ENGINEERING AT (608) 266-9721 FOR PRECAST APPROVALS, FAX SHOP DRAWINGS TO (608)264-9275, OR EMAIL SHOP DRAWINGS TO CSTELLJES@CITYOFMADISON.COM.

STORM SEWER REMOVAL SCHEDULE

REMOVE STORM STRUCTURES

| STRUC. NO. | ID NO. | STATION | LOCATION (OFFSET) | TYPE | NOTES |
|------------|-------------|----------|-------------------|-------|---------|
| RS-1 | AS 6345-015 | 4+22.51 | LT-30.87 | SAS | ABANDON |
| RS-2 | IN 6345-014 | 4+75.89 | LT-22.32 | INLET | REMOVE |
| RS-3 | IN 6346-002 | 4+78.38 | RT-21.70 | INLET | REMOVE |
| RS-4 | AS 6445-001 | 11+63.96 | LT-25.00 | SAS | REMOVE |
| RS-5 | AS 6445-004 | 13+81.22 | LT-17.00 | SAS | REMOVE |
| RS-6 | IN 6445-005 | 13+70.52 | LT-15.50 | INLET | REMOVE |
| RS-7 | IN 6445-006 | 13+78.31 | LT-15.50 | INLET | REMOVE |
| RS-8 | IN 6446-001 | 13+77.48 | RT-32.61 | INLET | REMOVE |
| RS-9 | IN 6446-003 | 13+60.00 | RT-48.00 | INLET | REMOVE |
| RS-10 | IN 6446-004 | 13+28.74 | RT-45.50 | INLET | REMOVE |
| RS-11 | IN 6446-002 | 13+15.00 | RT-30.00 | INLET | REMOVE |
| RS-12 | IN 6546-002 | 25+02.00 | RT-25.50 | SAS | REMOVE |
| RS-14 | IN 6446-013 | 22+40.00 | RT-30.00 | INLET | REMOVE |
| RS-15 | IN 6445-010 | 22+45.00 | LT-15.75 | SAS | REMOVE |
| RS-16 | AS 6445-007 | 22+47.40 | LT-21.75 | SAS | REMOVE |
| RS-17 | AS 6445-008 | 24+42.39 | LT-25.00 | SAS | REMOVE |
| RS-18 | IN 6445-013 | 24+42.55 | LT-16.60 | INLET | REMOVE |
| RS-19 | IN 6446-015 | 24+37.64 | RT-30.20 | INLET | REMOVE |
| RS-20 | IN 6446-014 | 24+60.18 | RT-45.29 | INLET | REMOVE |
| RS-21 | IN 6546-004 | 25+03.18 | RT-37.94 | INLET | REMOVE |
| RS-22 | IN 6546-034 | 25+16.63 | RT-31.54 | INLET | REMOVE |
| RS-23 | IN 6546-002 | 25+06.32 | LT-25.13 | INLET | REMOVE |
| RS-24 | AS 6545-009 | 25+07.96 | LT-36.75 | SAS | REMOVE |
| RS-25 | IN 6445-012 | 55+13.00 | LT-17.00 | INLET | REMOVE |
| RS-26 | IN 6445-011 | 55+22.00 | LT-17.00 | INLET | REMOVE |
| RS-27 | IN 6545-007 | 55+10.00 | RT-17.00 | INLET | REMOVE |
| RS-28 | 6545-008 | 55+17.00 | RT-17.00 | INLET | REMOVE |
| RS-29 | IN 6545-020 | 60+66.00 | RT-17.00 | INLET | REMOVE |
| RS-30 | AS 6544-011 | 60+73.00 | RT-22.25 | SAS | ABANDON |
| RS-31 | IN 6544-012 | 60+80.00 | RT-17.00 | INLET | REMOVE |
| RS-32 | IN 6444-017 | 60+67.00 | LT-17.00 | INLET | REMOVE |
| RS-33 | N/A | 60+72.00 | LT-17.00 | INLET | REMOVE |
| RS-34 | N/A | 60+67.00 | LT-41.00 | SAS | ABANDON |
| RS-35 | AS 6544-007 | 62+98.92 | RT-20.47 | SAS | REMOVE |
| RS-36 | IN 6544-009 | 62+99.93 | RT-29.13 | INLET | REMOVE |
| RS-37 | IN 6544-010 | 63+36.94 | RT-32.19 | INLET | REMOVE |
| RS-38 | IN 6544-008 | 63+47.14 | RT-21.27 | INLET | REMOVE |

STORM SEWER ULOs

| ULO NO. | STATION | LOCATION (OFFSET) | TYPE | ELEV TOP | ELEV BOTTOM | NOTES |
|---------|----------|-------------------|-----------|----------|-------------|--------------------------------------|
| ULO-23 | 24+49.00 | RT-48.00 | ELEC & FO | 861.76 | 857.00 | STORM SEWER REVISED, CAUTION |
| ULO-24 | 24+43.00 | RT-49.50 | ELEC | 858.35 | 855.28 | NO CONFLICT |
| ULO-25 | 24+50.00 | RT-50.00 | ELEC | 859.74 | 859.57 | NO CONFLICT |
| ULO-26 | 24+59.00 | RT-58.00 | ELEC | N/A | | SEE ULO 23 |
| ULO-27 | 53+43.00 | LT-8.00 | ELEC | 859.66 | 858.44 | MGE TO RELOCATE |
| ULO-28 | 55+15.00 | RT-21.50 | GAS | 859.66 | 858.44 | RAISE PVC +1.52' |
| ULO-29 | 56+09.00 | LT-10.00 | ELEC | 860.10 | 859.41 | RAISE PVC +0.55' |
| ULO-30 | 57+55.00 | LT-10.00 | ELECX3 | 860.33 | 859.39 | RAISE PVC +0.57' |
| ULO-31 | 57+43.00 | LT-10.00 | FO | N/A | | MOVED PER SURVEYOR'S NOTE |
| ULO-32 | 57+71.00 | LT-10.00 | GAS | 860.48 | 859.98 | OK, USE CAUTION |
| ULO-33 | 59+30.00 | LT-10.00 | ELEC | 861.39 | 860.61 | OK, USE CAUTION WITH BORE |
| ULO-34 | 59+72.00 | LT-10.00 | FO | 861.48 | 861.14 | NO CONFLICT |
| ULO-35 | 59+84.00 | LT-10.00 | FO | | | NOT MARKED |
| ULO-36 | 59+98.00 | LT-10.00 | FO | 861.79 | 861.58 | NO CONFLICT |
| ULO-37 | 61+48.00 | LT-10.00 | GAS;FO | 860.10 | 859.19 | GAS AND ATT TO RELOCATE (RAISE 1.5') |
| ULO-38 | 25+12.00 | RT-44.50 | TEL | 859.40 | | NO CONFLICT |
| ULO-39 | 25+31.00 | LT-32.30 | GAS | 856.62 | | NO CONFLICT |
| ULO-40 | 55+15.80 | LT-24.10 | FO | 858.44 | 858.02 | COMPLETED PRIOR TO PROJECT |
| ULO-41 | 8+14.79 | RT-29.10 | GAS | N/A | | GAS TO BE RELOCATED |
| ULO-42 | 18+95.00 | RT-34.00 | GAS | 861.55 | 861.00 | MGE TO ABN LINE |
| ULO-43 | 60+22.69 | LT-10.04 | STM BOX | 863.05 | 857.14 | EI=857.81 |
| ULO-44 | 60+05.00 | LT-10.00 | FO | 861.79 | 861.50 | NO CONFLICT |

REMOVE STORM PIPES

| REMOVE NO. | REMOVE FROM | REMOVE TO | LGTH (FT) | PIPE SIZE | PIPE TYPE | PAID (Y/N) | NOTES |
|------------|-------------|-----------|-----------|-----------|-----------|------------|---------------------------------|
| RP-1 | 1+91 | RS-1 | 229 | 15" | VP | N | ABN WITH PLUGS |
| RP-2 | RS-1 | RS-2 | 70 | 12" | VP | N | REMOVE |
| RP-3 | RS-1 | RS-3 | 90 | 12" | VP | Y | REMOVE |
| RP-4 | RS-4 | RS-5 | 212 | 18" | RCP | N | REMOVE |
| RP-5 | RS-5 | RS-8 | 48 | 12" | RCP | Y | REMOVE |
| RP-6 | RS-8 | RS-9 | 24 | 12" | RCP | Y | REMOVE |
| RP-7 | RS-9 | RS-10 | 30 | 12" | RCP | Y | REMOVE |
| RP-8 | RS-10 | RS-11 | 22 | 12" | RCP | Y | REMOVE |
| RP-9 | RS-16 | RS-17 | 194 | 18" | RCP | Y | REMOVE |
| RP-10 | RS-16 | RS-15 | 5 | 12" | RCP | Y | REMOVE |
| RP-11 | RS-15 | RS-14 | 46 | 12" | RCP | Y | REMOVE |
| RP-12 | RS-17 | RS-18 | 7 | 12" | RCP | Y | REMOVE |
| RP-13 | RS-17 | RS-24 | 67 | 18" | RCP | Y | REMOVE |
| RP-14 | RS-25 | RS-23 | 12 | 12" | RCP | N | REMOVE |
| RP-15 | RS-24 | RS-12 | 56 | 18" | RCP | N | REMOVE |
| RP-16 | RS-12 | RS-19 | 58 | 12" | RCP | Y | REMOVE |
| RP-17 | RS-12 | RS-20 | 41 | 12" | RCP | Y | REMOVE |
| RP-18 | RS-12 | RS-21 | 7 | 12" | RCP | Y | REMOVE |
| RP-19 | RS-12 | RS-22 | 10 | 12" | RCP | N | REMOVE |
| RP-20 | RS-26 | RS-28 | 28 | 12" | RCP | N | REMOVE |
| RP-21 | RS-25 | RS-27 | 28 | 12" | RCP | N | REMOVE |
| RP-22 | RS-33 | RS-34 | 23 | 12" | RCP | N | ABANDON WITH PLUGS (INCIDENTAL) |
| RP-23 | RS-33 | RS-31 | 36 | 12" | RCP | N | REMOVE |
| RP-24 | RS-29 | RS-30 | 5 | 12" | RCP | Y | REMOVE |
| RP-25 | RS-31 | RS-30 | 5 | 12" | RCP | N | REMOVE |
| RP-26 | RS-30 | RS-35 | 220 | 15" | RCP | N | ABANDON WITH PLUGS (INCIDENTAL) |
| RP-27 | RS-35 | RS-38 | 46 | 12" | RCP | Y | REMOVE |
| RP-28 | RS-35 | RS-36 | 7 | 12" | RCP | Y | REMOVE |
| RP-29 | RS-35 | RS-37 | 36 | 12" | RCP | N | REMOVE |
| RP-30 | S-30 | 1+91 | 25 | 15" | VP | Y | REMOVE |

STORM SEWER ULOs

| ULO NO. | STATION | LOCATION (OFFSET) | TYPE | ELEV TOP | ELEV BOTTOM | NOTES |
|---------|----------|-------------------|------------|----------|-------------|-----------------|
| ULO-25A | 24+99.99 | RT-62.30 | 6" STL GAS | 861.48 | | NEED GAS WINDOW |
| ULO-2A | 63+49.80 | RT-26.10 | 3" FO | 855.18 | | NO CONFLICT |
| ULO-1A | 6310.6 | 25.6 | 3" FO | 855.38 | | NO CONFLICT |

STANDARD NOTES:

- ABBREVIATIONS: AE = APRON ENDWALL; RCP = REINFORCED CONCRETE PIPE; HERCP = HORIZONTAL ELLIPTICAL REINFORCED CONCRETE PIPE; DNA = DOES NOT APPLY; SAS = SEWER ACCESS STRUCTURE; LP = LOW POINT INLET STRUCTURE; FP = FIELD POURED STRUCTURE; TR = TOP OF CONCRETE ROOF; NCM = NO CROWN MATCH FOR PIPES; UD = UNDERDRAIN
- APPROXIMATE DISCHARGE E.I. GIVEN, ADJUST E.I. AND PIPE SLOPE IN THE FIELD.
- TOP OF CASTING GRADE GIVEN IS THE TOP OF CURB FOR INLET STRUCTURES AND THE FLOWLINE OF THE CLOSED CASTING FOR SAS's.
- TOP OF CONCRETE ROOF (TR) IS 1.25' BELOW TOP OF CASTING UNLESS OTHERWISE NOTED.
- ALL REINFORCED CONCRETE PIPES TO BE CLASS III UNLESS OTHERWISE NOTED.
- SURVEYOR TO CONFIRM THAT ALL INLET STATION / OFFSETS LINE UP WITH PROPOSED CURB AND GUTTER.
- ALL STRUCTURES CALLED OUT AS FIELD POURED SHALL BE FIELD POURED. ALL OTHER STRUCTURES (NOT INDICATED AS FIELD POURED) SHALL BE SUBMITTED TO CITY ENGINEERING FOR APPROVAL IF PRECAST STRUCTURES ARE PREFERRED. CONTACT COREY STELLJES OF CITY ENGINEERING AT (608) 266-9721 FOR PRECAST APPROVALS, FAX SHOP DRAWINGS TO (608)264-9275, OR EMAIL SHOP DRAWINGS TO CSTELLJES@CITYOFMADISON.COM.

CASING PIPE TO
BE SIZED BY THE CONTRACTOR
MIN. CASING SIZE PER SPECIAL PROVISIONS

FILL VOIDS W/ BLOWN SAND.

NOTE:

WALL THICKNESS FOR STEEL
CASING PIPE WITH 35,000 P.S.I.
MIN. YIELD STRENGTH. FOR
MATERIAL OF LOWER YIELD
STRENGTH, INCREASE THICKNESS
AN ADDITIONAL $\frac{1}{16}$ ".

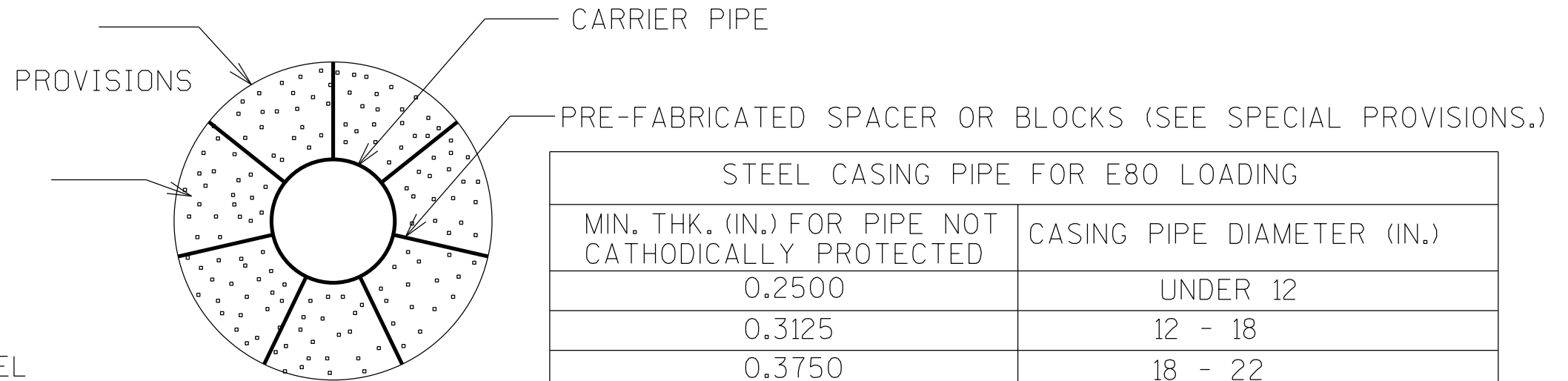

| STEEL CASING PIPE FOR E80 LOADING | |
|-----------------------------------------------------|----------------------------|
| MIN. THK. (IN.) FOR PIPE NOT CATHODICALLY PROTECTED | CASING PIPE DIAMETER (IN.) |
| 0.2500 | UNDER 12 |
| 0.3125 | 12 - 18 |
| 0.3750 | 18 - 22 |
| 0.4375 | 22 - 25 |
| 0.500 | 25 - 34 |
| 0.5625 | 34 - 42 |
| 0.6250 | 42 - 48 |

CASING PIPE DETAIL

NTS

PLOT SCALE:

PLOT NAME:

REV. DATE:

ORIGINATOR: CITY OF MADISON, STREETS DIVISION



MATCHLINE STA 11+00.00

MATCHLINE STA 16+00.00

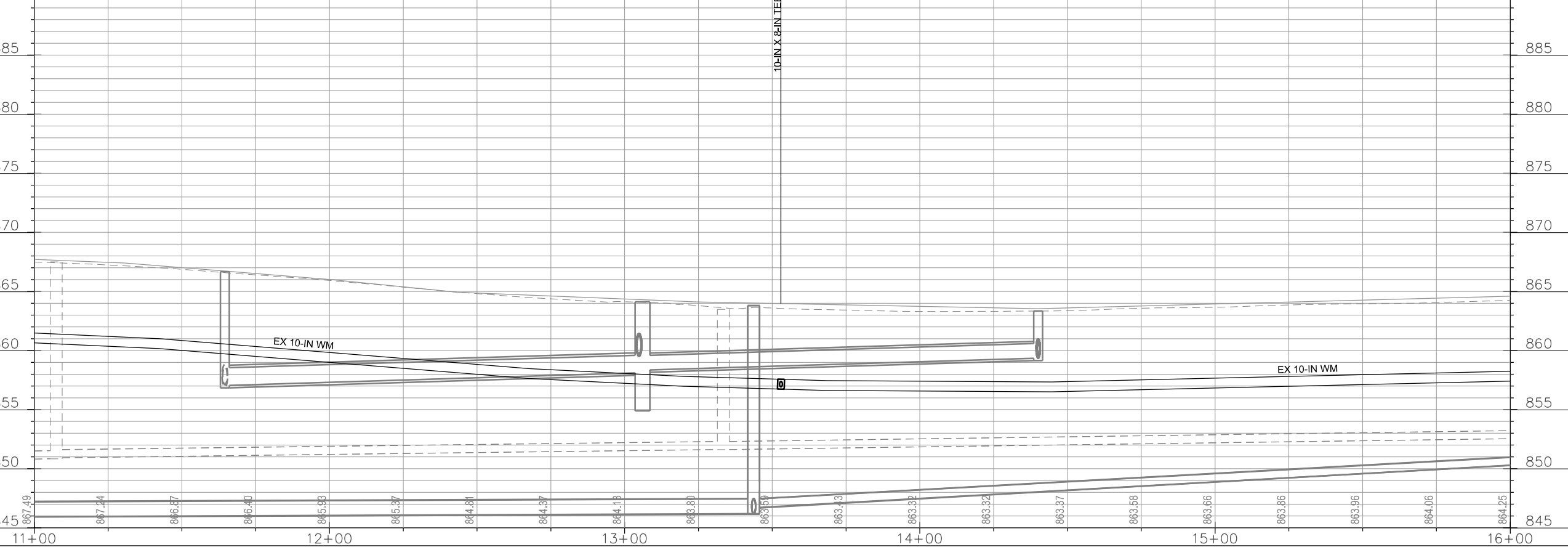
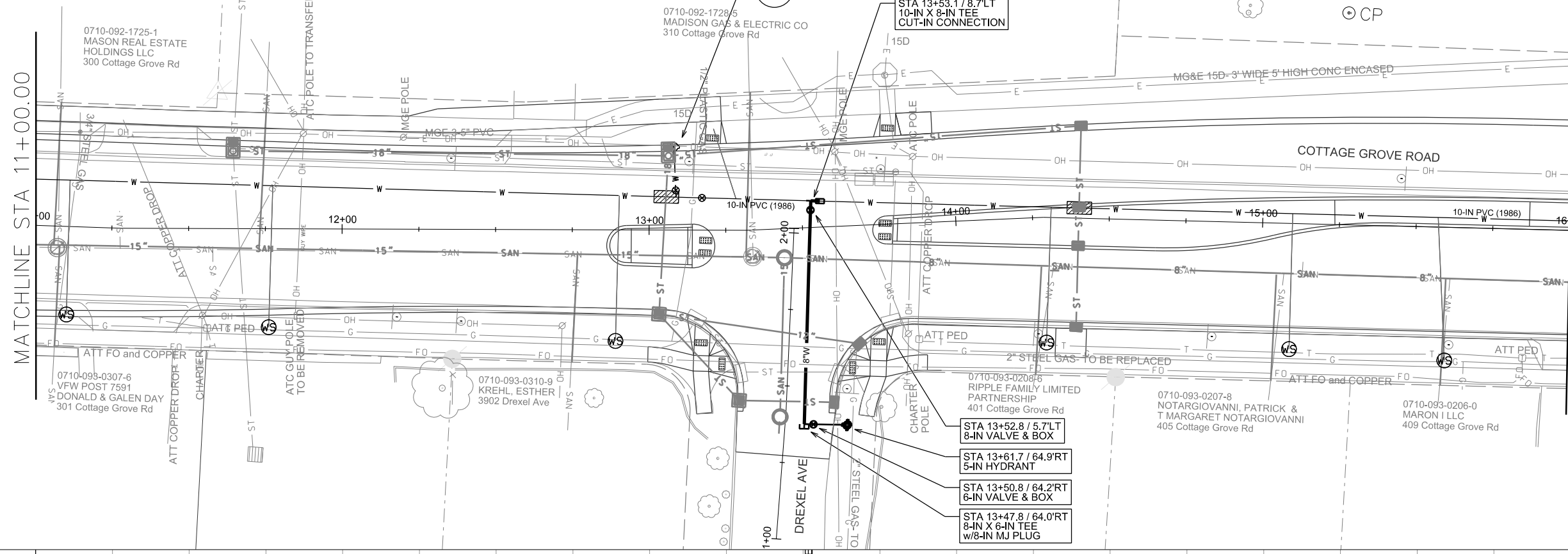

PLOT SCALE: _____

REV. DATE: _____

ORIGINATOR: CITY OF MADISON, STREETS DIVISION



MATCHLINE STA 21+00.00

MATCHLINE STA 26+00.00

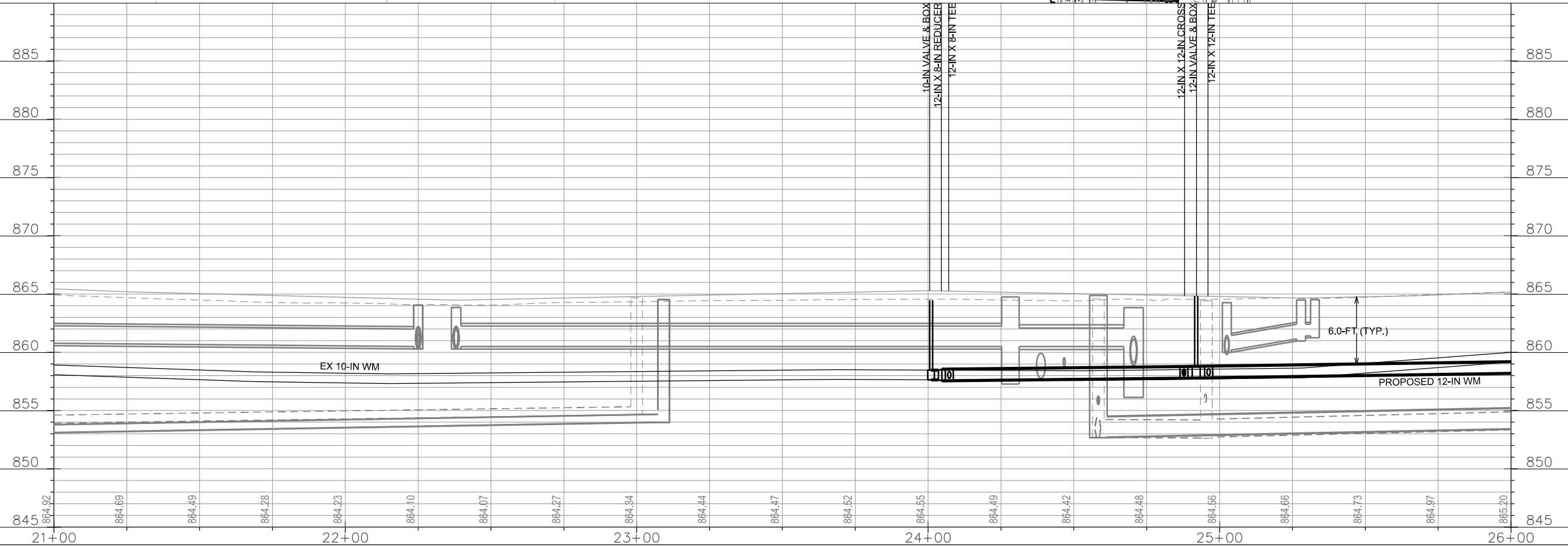
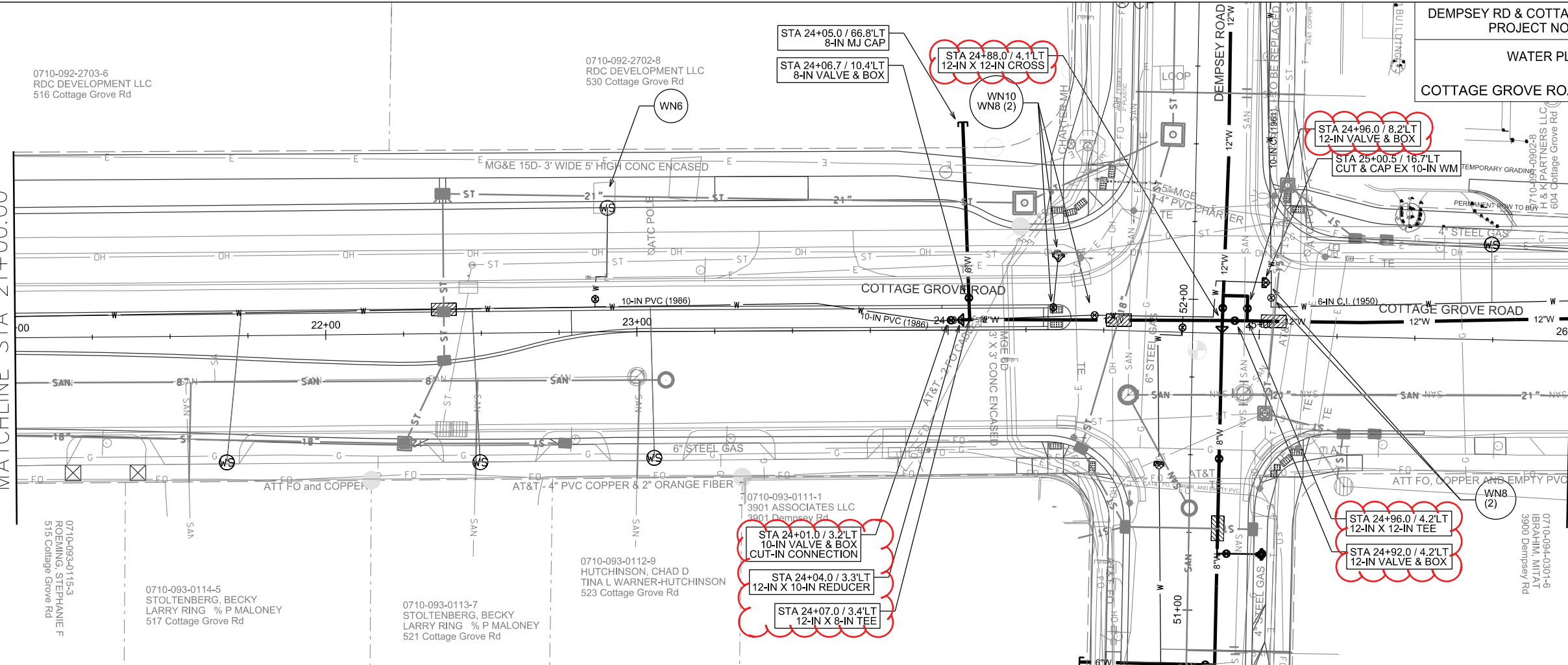

PLOT SCALE: _____

PLOT NAME: _____

REV. DATE: _____

ORIGINATOR: CITY OF MADISON, STREETS DIVISION

0710-092-2703-6
RDC DEVELOPMENT LLC
516 Cottage Grove Rd

0710-092-2702-8
RDC DEVELOPMENT LLC
530 Cottage Grove Rd

0710-093-0115-3
ROEMING, STEPHANIE F
515 Cottage Grove Rd

0710-093-0114-5
STOLTENBERG, BECKY
LARRY RING % P MALONEY
517 Cottage Grove Rd

0710-093-0113-7
STOLTENBERG, BECKY
LARRY RING % P MALONEY
521 Cottage Grove Rd

0710-093-0112-9
HUTCHINSON, CHAD D
TINA L WARNER-HUTCHINSON
523 Cottage Grove Rd

0710-093-0111-1
3901 ASSOCIATES LLC
3901 Dempsey Rd

0710-092-0902-8
H & K PARTNERS LLC
604 Cottage Grove Rd

0710-094-0301-6
BRASHIM, MITTAT
3900 Dempsey Rd

STA 24+01.0 / 3.2'LT
10-IN VALVE & BOX
CUT-IN CONNECTION

STA 24+04.0 / 3.3'LT
12-IN X 10-IN REDUCER

STA 24+07.0 / 3.4'LT
12-IN X 8-IN TEE

STA 24+88.0 / 4.1'LT
12-IN X 12-IN CROSS

STA 24+96.0 / 8.2'LT
12-IN VALVE & BOX

STA 25+00.5 / 16.7'LT
CUT & CAP EX 10-IN WM

STA 24+96.0 / 4.2'LT
12-IN X 12-IN TEE

STA 24+92.0 / 4.2'LT
12-IN VALVE & BOX

WATER PLAN AND PROFILE
COTTAGE GROVE ROAD CITY OF MADISON

Revision 1 - 4/13

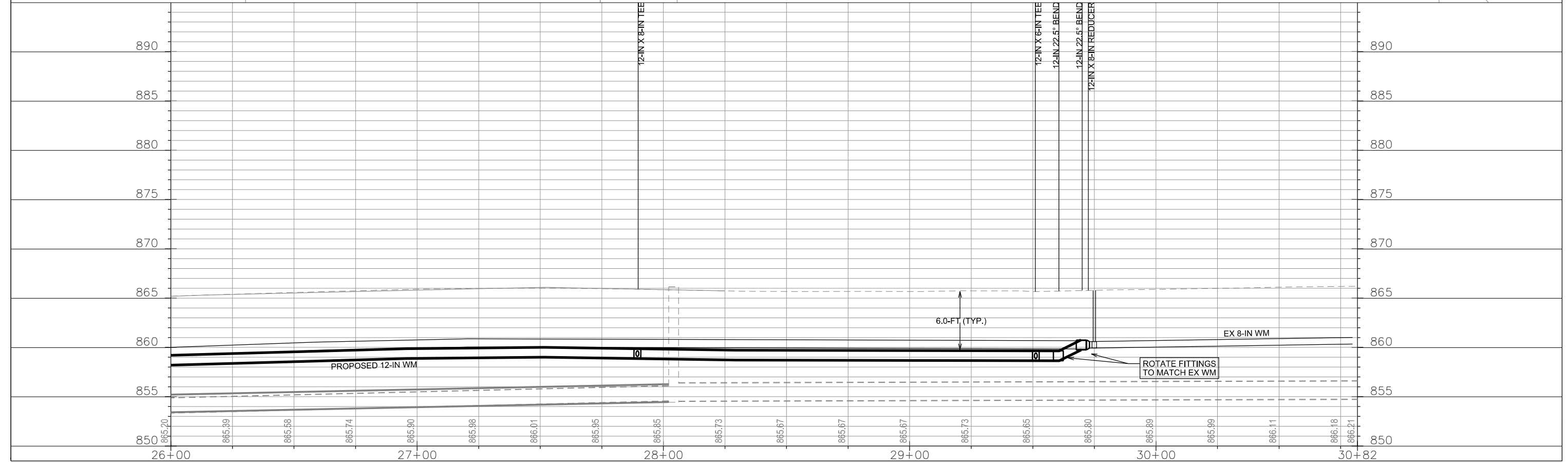
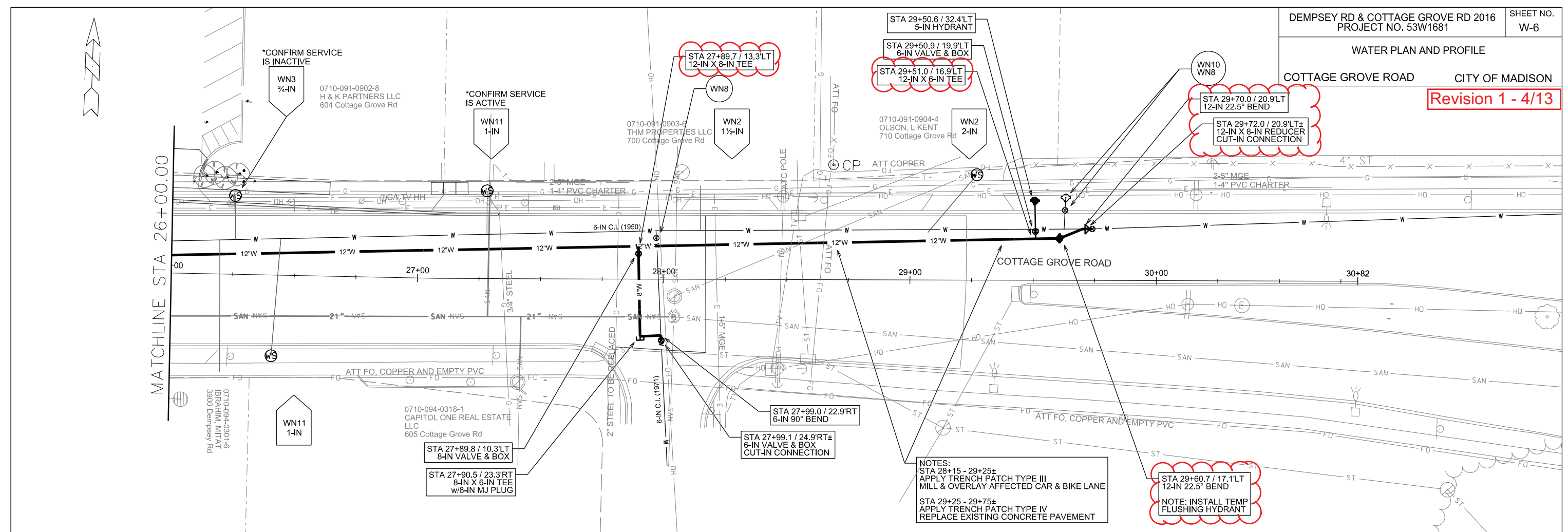

PLOT SCALE: _____

REV. DATE: _____

ORIGINATOR: CITY OF MADISON, STREETS DIVISION

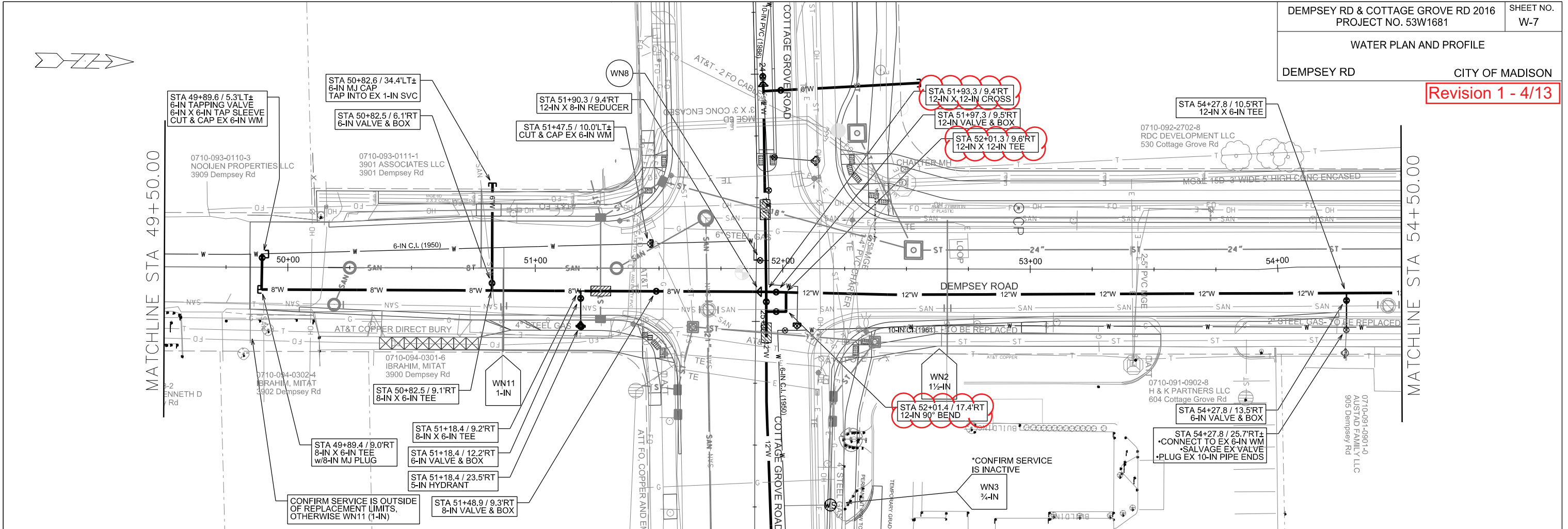

Revision 2 - 4/26

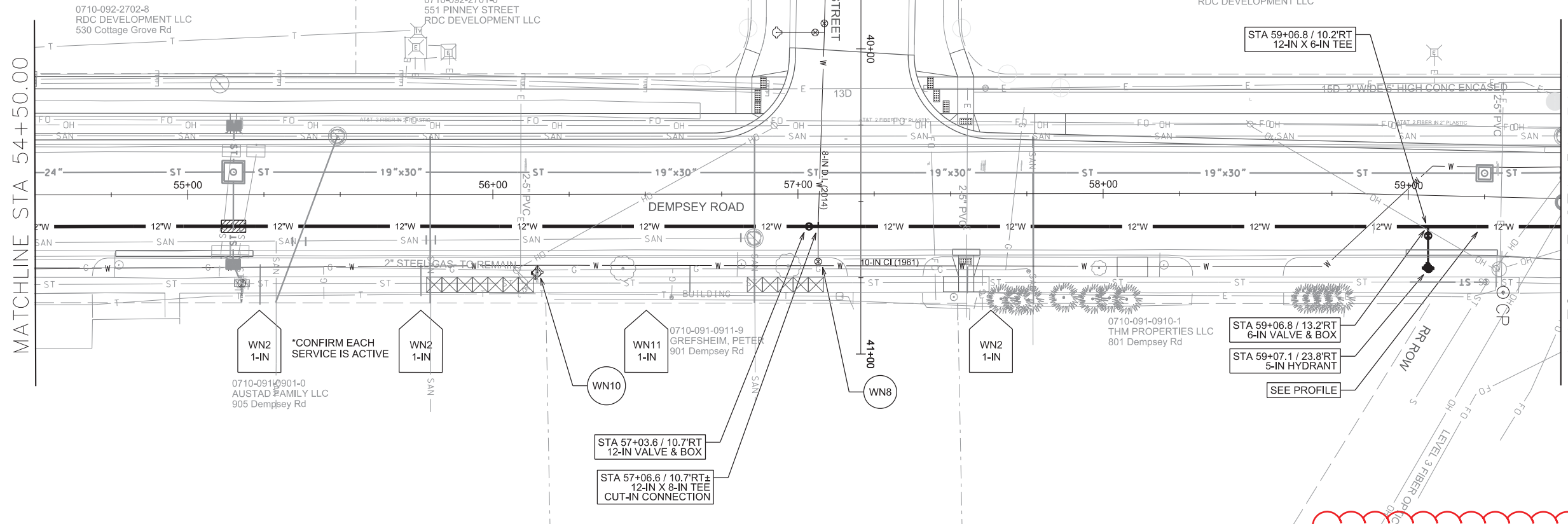

MATCHLINE STA 54+50.00

MATCHLINE STA 59+50.00

PLOT SCALE: _____
PLOT NAME: _____

REV. DATE: _____

ORIGINATOR: CITY OF MADISON, STREETS DIVISION

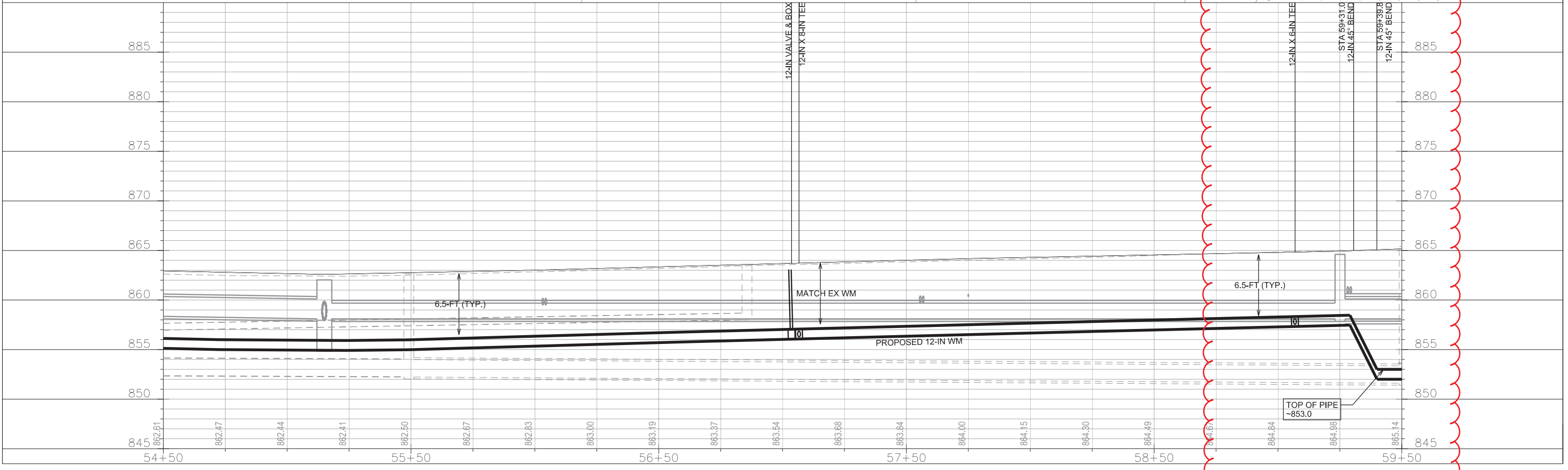

Revision 2 - 4/26

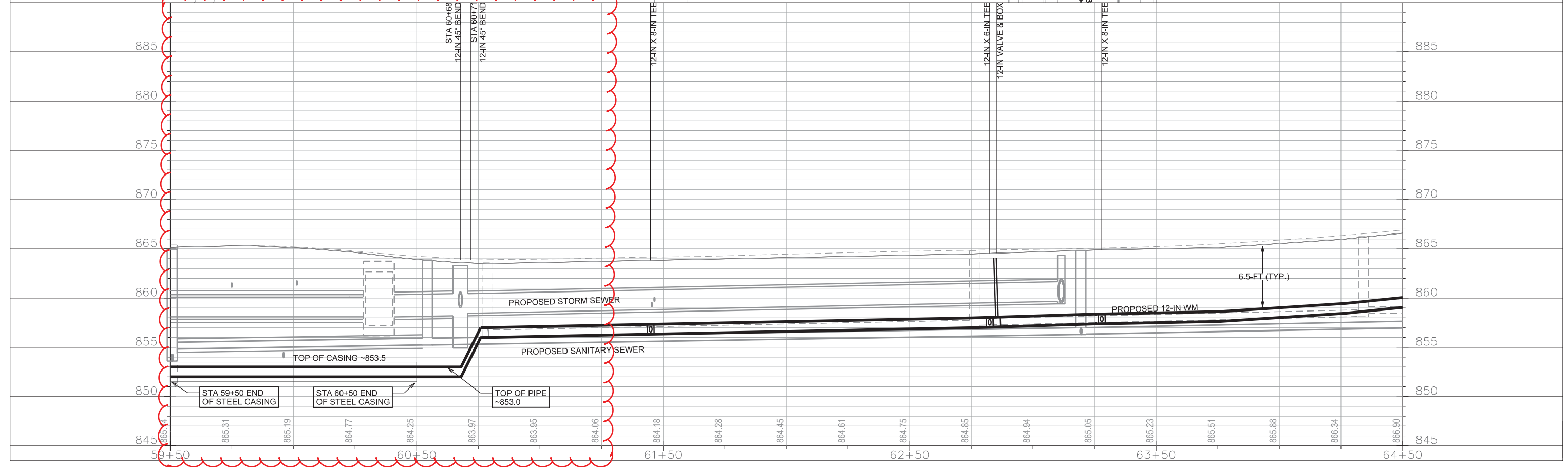
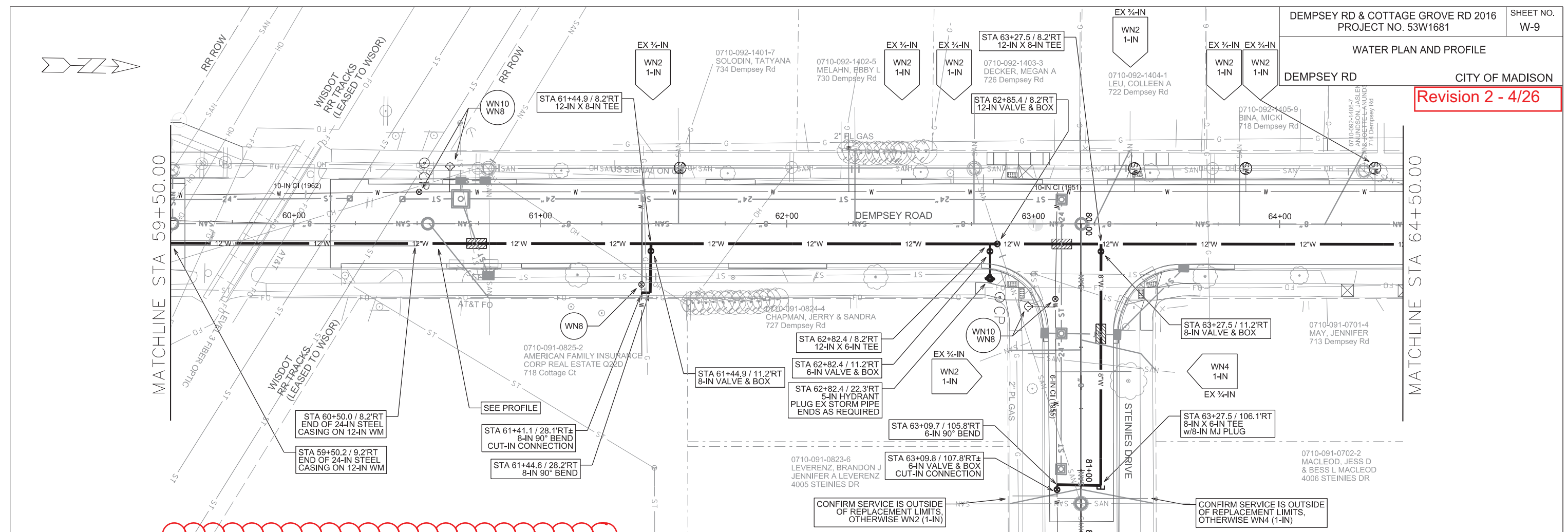

WATER PLAN AND PROFILE

DEMPSEY RD CITY OF MADISON

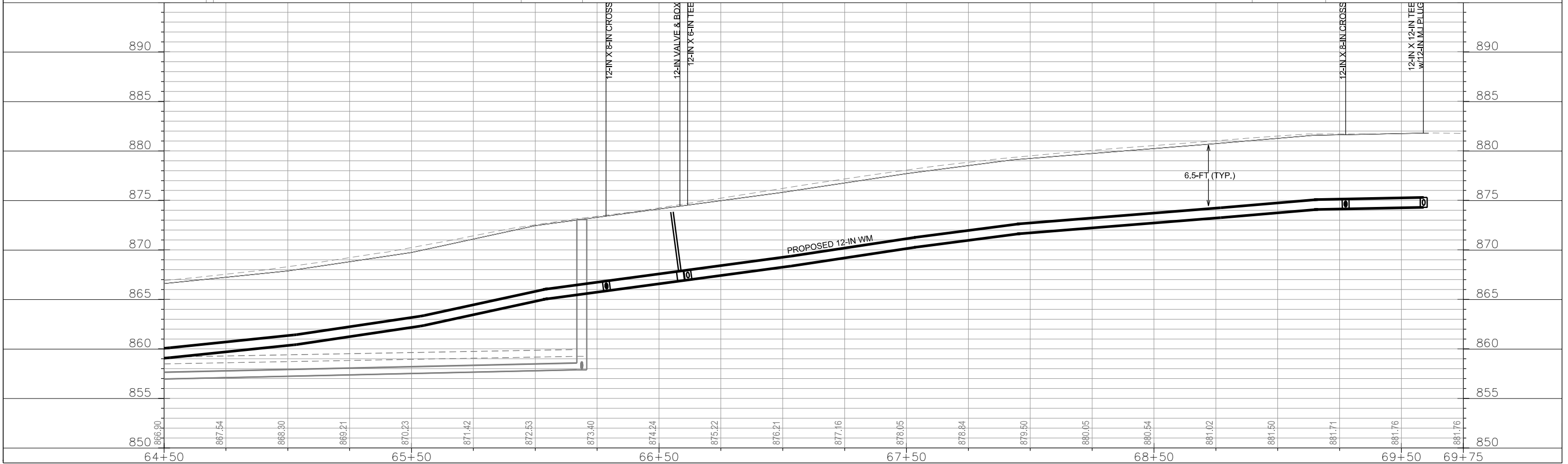
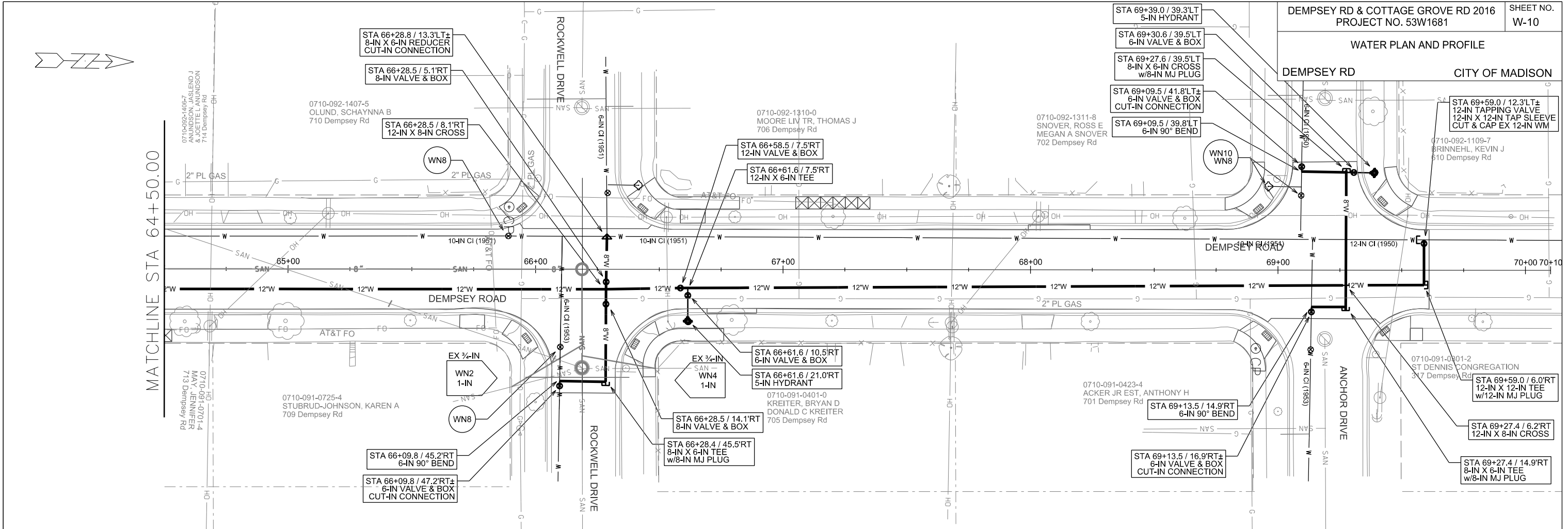

PLOT SCALE: _____

PLOT NAME: _____

REV. DATE: _____

ORIGINATOR: CITY OF MADISON, STREETS DIVISION

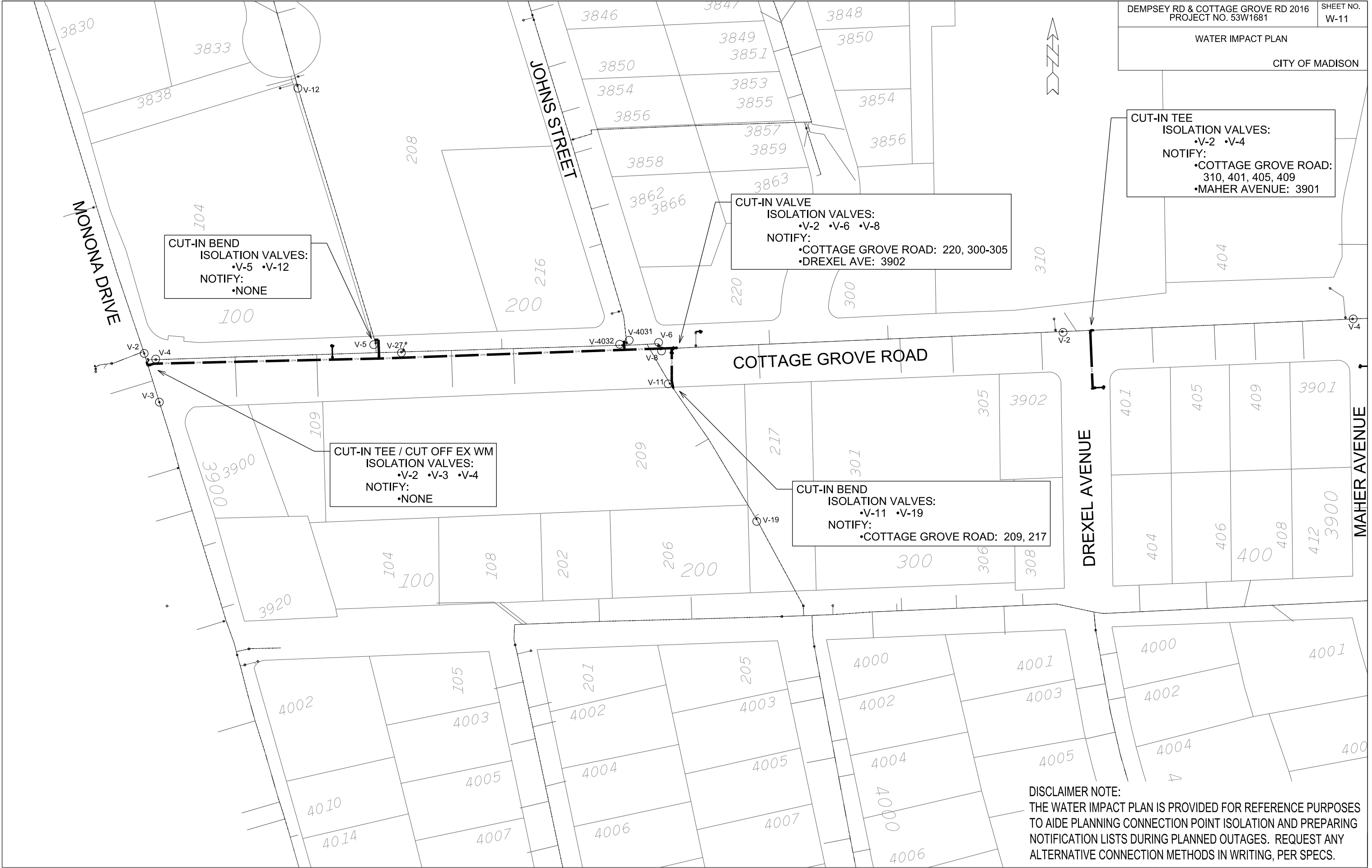

CUT-IN BEND
ISOLATION VALVES:
•V-5 •V-12
NOTIFY:
•NONE

CUT-IN VALVE
ISOLATION VALVES:
•V-2 •V-6 •V-8
NOTIFY:
•COTTAGE GROVE ROAD: 220, 300-305
•DREXEL AVE: 3902

CUT-IN TEE
ISOLATION VALVES:
•V-2 •V-4
NOTIFY:
•COTTAGE GROVE ROAD:
310, 401, 405, 409
•MAHER AVENUE: 3901

CUT-IN TEE / CUT OFF EX WM
ISOLATION VALVES:
•V-2 •V-3 •V-4
NOTIFY:
•NONE

CUT-IN BEND
ISOLATION VALVES:
•V-11 •V-19
NOTIFY:
•COTTAGE GROVE ROAD: 209, 217

DISCLAIMER NOTE:
THE WATER IMPACT PLAN IS PROVIDED FOR REFERENCE PURPOSES TO AIDE PLANNING CONNECTION POINT ISOLATION AND PREPARING NOTIFICATION LISTS DURING PLANNED OUTAGES. REQUEST ANY ALTERNATIVE CONNECTION METHODS IN WRITING, PER SPECS.

PLOT SCALE: _____

PLOT NAME: _____

REV. DATE: _____

ORIGINATOR: CITY OF MADISON, STREETS DIVISION

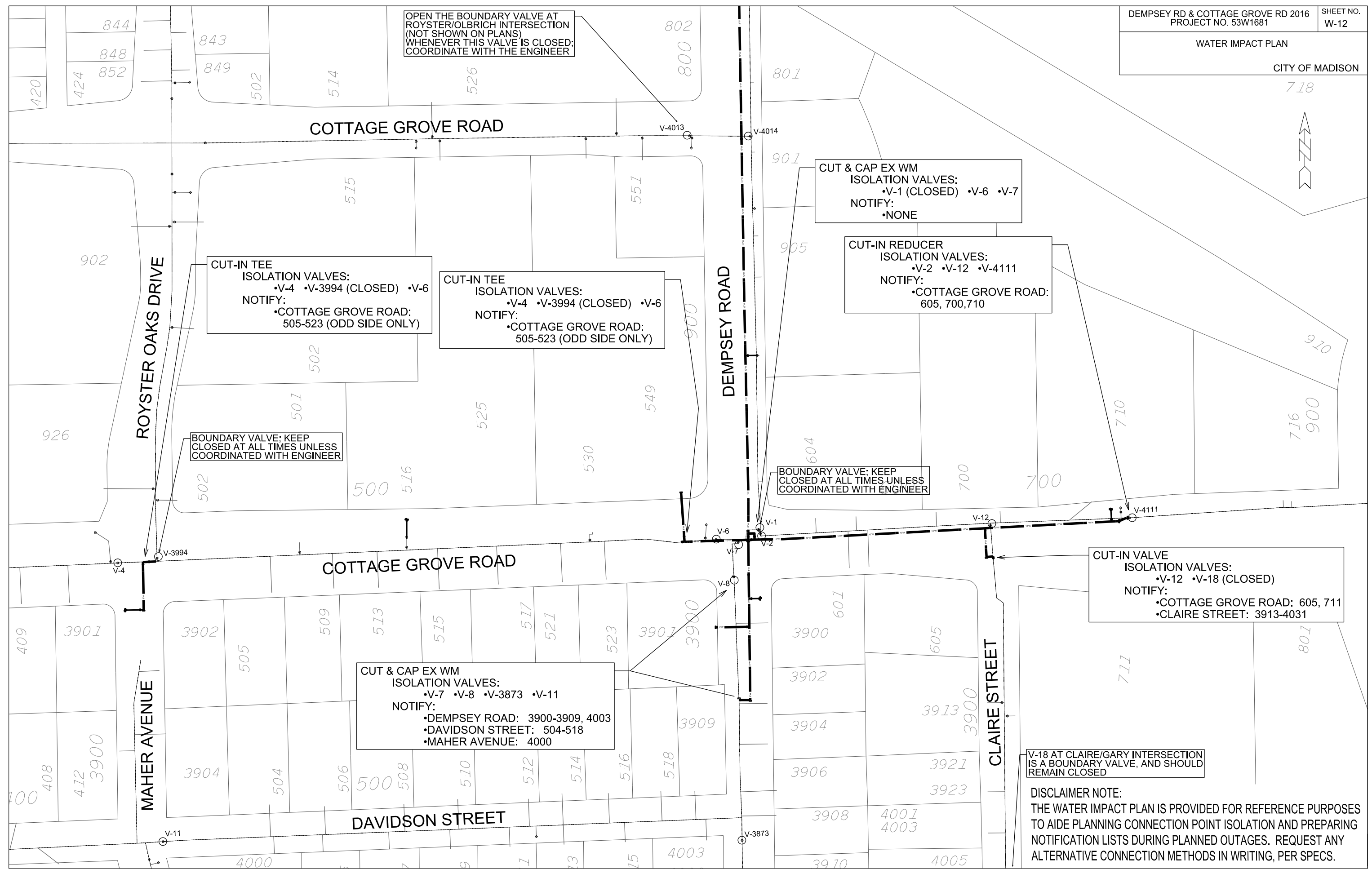

OPEN THE BOUNDARY VALVE AT ROYSTER/OLBRICH INTERSECTION (NOT SHOWN ON PLANS) WHENEVER THIS VALVE IS CLOSED; COORDINATE WITH THE ENGINEER

CUT-IN TEE
ISOLATION VALVES:
•V-4 •V-3994 (CLOSED) •V-6
NOTIFY:
•COTTAGE GROVE ROAD:
505-523 (ODD SIDE ONLY)

CUT-IN TEE
ISOLATION VALVES:
•V-4 •V-3994 (CLOSED) •V-6
NOTIFY:
•COTTAGE GROVE ROAD:
505-523 (ODD SIDE ONLY)

CUT & CAP EX WM
ISOLATION VALVES:
•V-1 (CLOSED) •V-6 •V-7
NOTIFY:
•NONE

CUT-IN REDUCER
ISOLATION VALVES:
•V-2 •V-12 •V-4111
NOTIFY:
•COTTAGE GROVE ROAD:
605, 700, 710

BOUNDARY VALVE; KEEP CLOSED AT ALL TIMES UNLESS COORDINATED WITH ENGINEER

BOUNDARY VALVE; KEEP CLOSED AT ALL TIMES UNLESS COORDINATED WITH ENGINEER

CUT & CAP EX WM
ISOLATION VALVES:
•V-7 •V-8 •V-3873 •V-11
NOTIFY:
•DEMPSEY ROAD: 3900-3909, 4003
•DAVIDSON STREET: 504-518
•MAHER AVENUE: 4000

CUT-IN VALVE
ISOLATION VALVES:
•V-12 •V-18 (CLOSED)
NOTIFY:
•COTTAGE GROVE ROAD: 605, 711
•CLAIRE STREET: 3913-4031

V-18 AT CLAIRE/GARY INTERSECTION IS A BOUNDARY VALVE, AND SHOULD REMAIN CLOSED

DISCLAIMER NOTE:
THE WATER IMPACT PLAN IS PROVIDED FOR REFERENCE PURPOSES TO AIDE PLANNING CONNECTION POINT ISOLATION AND PREPARING NOTIFICATION LISTS DURING PLANNED OUTAGES. REQUEST ANY ALTERNATIVE CONNECTION METHODS IN WRITING, PER SPECS.

PLOT SCALE: _____
 PLOT NAME: _____
 REV. DATE: _____
 ORIGINATOR: CITY OF MADISON, STREETS DIVISION

DISCLAIMER NOTE:
 THE WATER IMPACT PLAN IS PROVIDED FOR REFERENCE PURPOSES TO AIDE PLANNING CONNECTION POINT ISOLATION AND PREPARING NOTIFICATION LISTS DURING PLANNED OUTAGES. REQUEST ANY ALTERNATIVE CONNECTION METHODS IN WRITING, PER SPECS.

WATER IMPACT PLAN

CITY OF MADISON

PLOT SCALE: _____

PLOT NAME: _____

REV. DATE: _____

ORIGINATOR: CITY OF MADISON, STREETS DIVISION

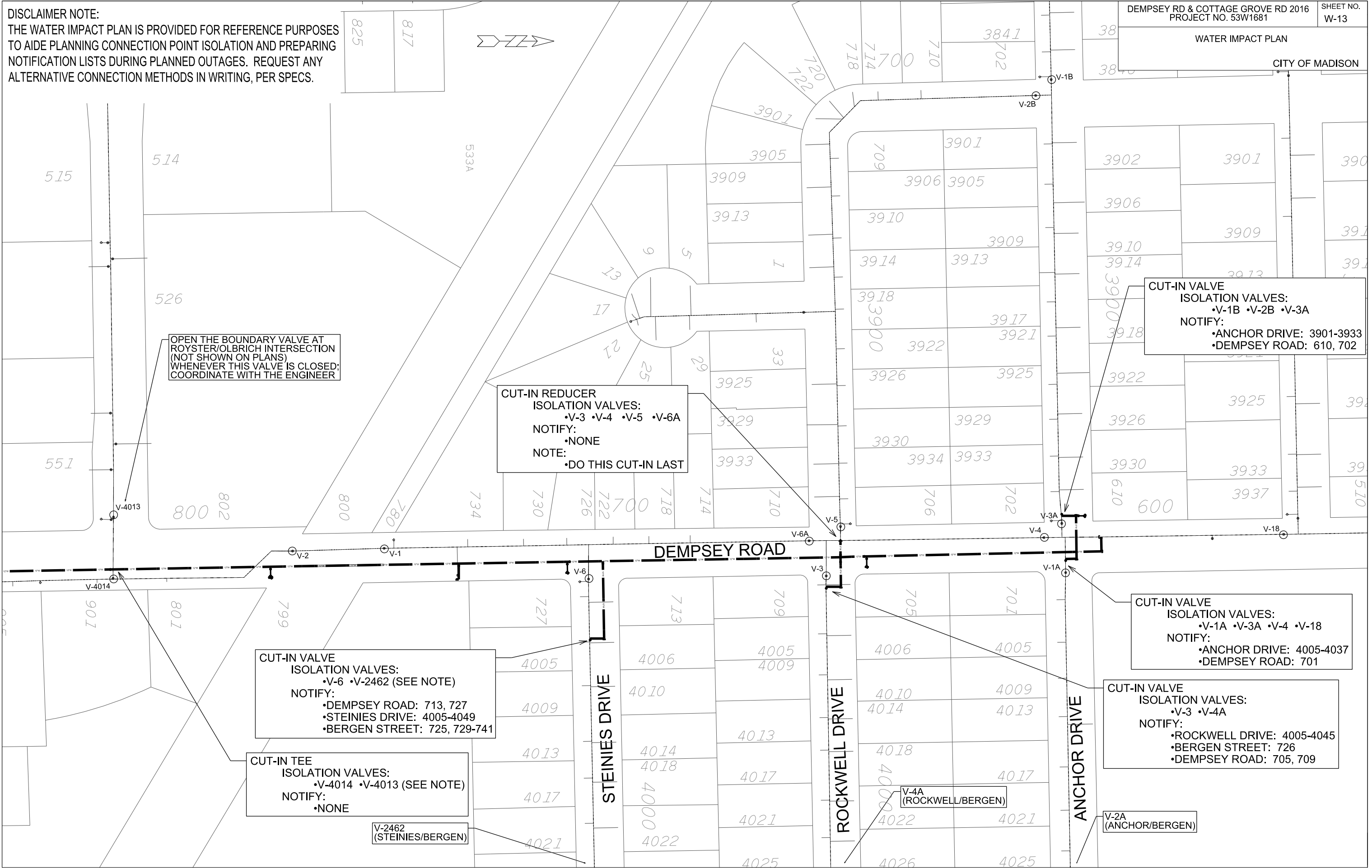

Revision 1 - 4/13

CONSTRUCTION NOTES:

1. CONSTRUCT NEW WATER MAIN 6.0' BELOW FINISHED GRADE, UNLESS OTHERWISE NOTED. INSULATE MAIN WITH POLYSTYRENE BOARD AT UTILITY CROSSINGS OR OTHER AREAS IDENTIFIED BY ENGINEER AS HAVING INADEQUATE COVER.
 2. VERIFY SIZE OF EXISTING WATER SERVICES AND RECONNECT SERVICES AS INDICATED.
 3. MINIMIZE DISRUPTION OF SERVICE TO EXISTING CUSTOMERS. NOTIFY PER CONTRACT REQUIREMENTS OF ANY PLANNED WATER OUTAGE.
 4. THE EXISTING UTILITIES SHOWN ON THIS PLAN REPRESENT THE BEST INFORMATION AVAILABLE TO THE WATER UTILITY AT THE TIME OF PLAN PREPARATION. CONTRACTOR IS RESPONSIBLE FOR HAVING EACH UTILITY LOCATED PRIOR TO COMMENCING WORK.
- WN1 REPLACE THE EXISTING LEAD SERVICE WITH A NEW COPPER SERVICE.
- WN2 EXTEND AND RECONNECT THE EXISTING COPPER SERVICE TO THE NEW WATER MAIN.
- WN3 EXISTING SERVICE TO BE ABANDONED WHEN THE WATER MAIN IS CUT OFF.
- WN4 DISCONNECT FROM THE OLD WATER MAIN AND RECONNECT THE EXISTING COPPER WATER SERVICE LATERAL TO THE NEW WATER MAIN.
- WN5 RELOCATE THE EXISTING FIRE HYDRANT.
- WN6 ABANDON WATER VALVE ACCESS STRUCTURE.
- WN7 FURNISH AND INSTALL THE NEW TOP SECTION FOR THE WATER ACCESS STRUCTURE.
- WN8 ABANDON THE VALVE BOX.
- WN9 FURNISH THE DITCH, COMPACTION, AND ALL MATERIALS AND LABOR FOR THE INSTALLATION OF NEW SERVICE LATERAL.
- WN10 REMOVE AND SALVAGE EXISTING HYDRANT
- WN11 REPLACE THE EXISTING COPPER SERVICE WITH A COPPER SERVICE

WN20+ SEE WATER IMPACT PLAN FOR CONNECTION POINT ISOLATION AND WATER SHUT-OFF NOTIFICATION INFORMATION.

ESTIMATE OF MATERIALS SUPPLIED BY CONTRACTOR/SALVAGED*:

* ESTIMATE OF MATERIALS IS FOR INFORMATION ONLY. ENGINEER DOES NOT GUARANTEE ACCURACY OF MATERIAL TAKE-OFF.

| WATER PIPE AND FITTINGS | TOTAL | OTHER MATERIALS | TOTAL |
|-------------------------|-------|--------------------------------|--------------|
| 6-IN PIPE (LF) | 340 | 1-IN TO TO 2-IN COPPER TUBING | AS REQ |
| 8-IN PIPE (LF) | 700 | 2-IN STYROFOAM INSULATION (LF) | 120 |
| 10-IN PIPE (LF) | 25 | PIPE PLUGS | 4 |
| 12-IN PIPE (LF) | 3030 | | |
| POLY WRAP | 4600 | | |
| 6-IN VALVES & BOXES | 17 | MATERIALS FROM CITY | TOTAL |
| 8-IN VALVES & BOXES | 8 | 6-IN X 6-IN TAPPING SLEEVE | 1 |
| 10-IN VALVES & BOXES | 2 | 12-IN X 12-IN TAPPING SLEEVE | 1 |
| 12-IN VALVES & BOXES | 7 | 6-IN TAPPING VALVE | 1 |
| 6-IN - 11.25° BENDS | 1 | 12-IN TAPPING VALVE | 1 |
| 6-IN - 22.5° BENDS | 1 | | |
| 6-IN - 90° BENDS | 6 | | |
| 8-IN - 90° BENDS | 4 | | |
| 12-IN - 11.25° BENDS | 1 | | |
| 12-IN - 22.5° BENDS | 2 | | |
| 12-IN - 45° BENDS | 2 | | |
| 12-IN - 90° BENDS | 1 | | |
| 8-IN X 6-IN TEES | 9 | | |
| 10-IN X 8-IN TEES | 2 | | |
| 12-IN X 6-IN TEES | 8 | | |
| 12-IN X 8-IN TEES | 6 | | |
| 12-IN X 12-IN TEES | 4 | | |
| 8-IN X 6-IN CROSSES | 1 | | |
| 12-IN X 8-IN CROSSES | 2 | | |
| 12-IN X 12-IN CROSSES | 1 | | |
| 8-IN MJ PLUGS | 7 | | |
| 12-IN MJ PLUGS | 1 | | |
| 6-IN CAPS | 2 | | |
| 8-IN CAPS | 2 | | |
| 12-IN CAPS | 1 | | |
| 8-IN X 6-IN REDUCER | 1 | | |
| 12-IN X 8-IN REDUCER | 2 | | |
| 12-IN X 10-IN REDUCER | 2 | | |
| 8-IN SOLID SLEEVES | 1 | | |
| 12-IN X 18-IN OFFSETS | 1 | | |
| 5-IN HYDRANTS | 11 | | |

TO OBTAIN LOCATION OF PARTICIPANTS' UNDERGROUND FACILITIES BEFORE YOU DIG IN WISCONSIN

CALL DIGGERS HOTLINE
TOLL FREE
811 OR 1-800-242-8511
FAX-A-LOCATE 1-800-338-3860
TDD (FOR HEARING IMPAIRED) 1-800-542-2289

WIS. STATUTE 182.0175 (1974)
REQUIRES MIN. OF 3 WORK DAYS
NOTICE BEFORE YOU EXCAVATE.

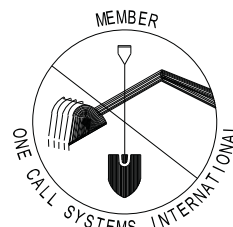

DISCLAIMER NOTE:
UTILITY LOCATIONS SHOWN ARE APPROXIMATE ONLY. IT SHALL BE THE CONTRACTOR'S RESPONSIBILITY TO DETERMINE THE EXACT HORIZONTAL AND VERTICAL LOCATION OF ALL EXISTING UNDERGROUND AND OVERHEAD UTILITIES PRIOR TO COMMENCING WORK.

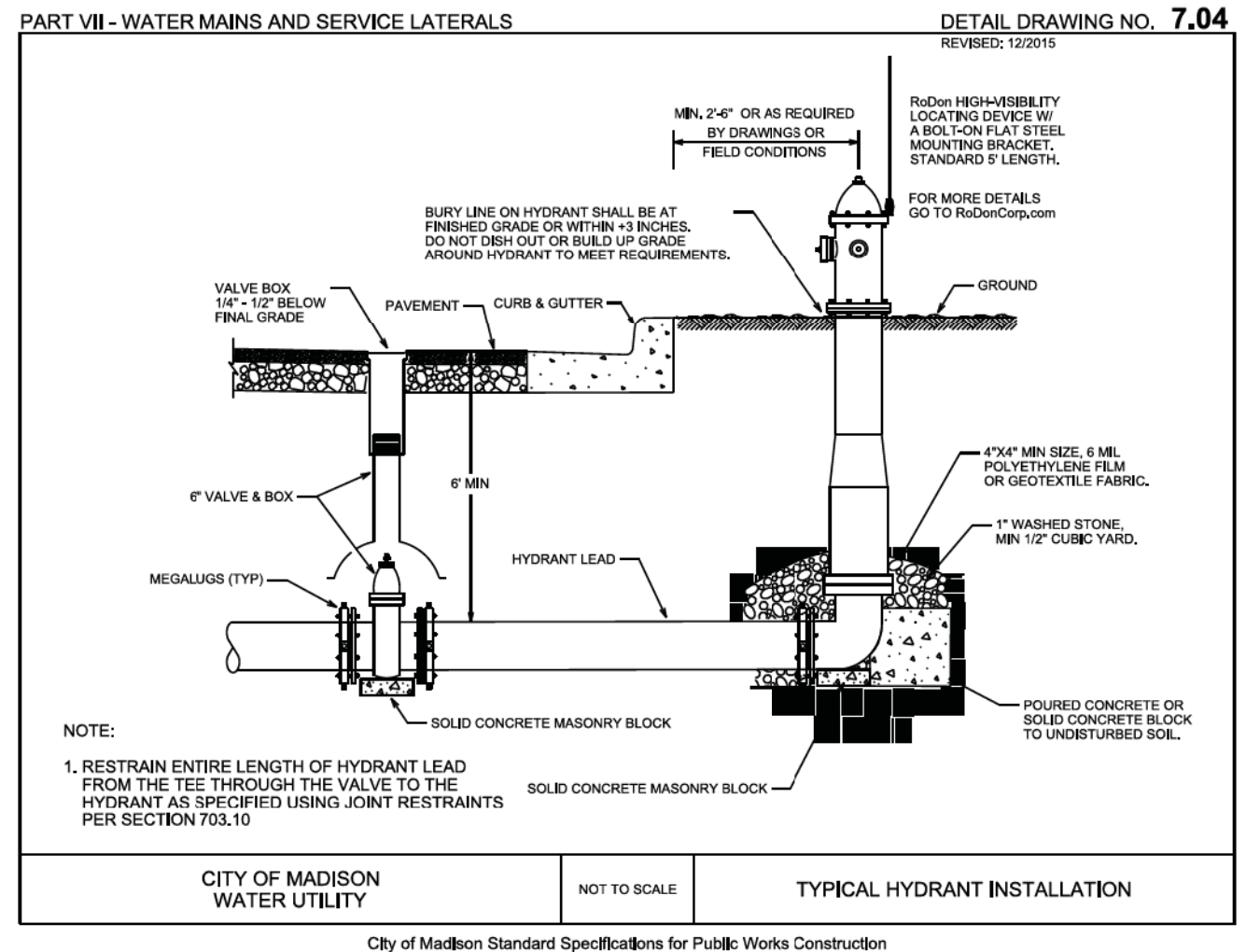
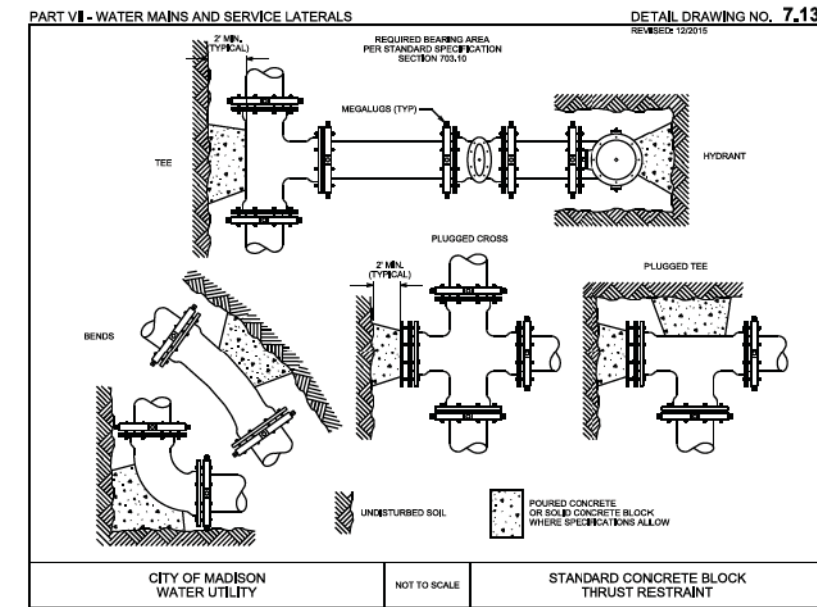

PLOT SCALE: _____

PLOT NAME: _____

REV. DATE: _____

ORIGINATOR: CITY OF MADISON, STREETS DIVISION



GENERAL ELECTRIC NOTES:

- ALL LOCATIONS ARE APPROXIMATE. THE TRAFFIC ENGINEER SHALL APPROVE FINAL LOCATIONS, INCLUDING SETBACK, IN THE FIELD AFTER CONTRACTOR SURVEYS STAKING. THE CONTRACTOR SHALL NOTIFY YANG TAO (266-4815) CITY TRAFFIC ENGINEERING, AT LEAST 24-HOURS IN ADVANCE OF NEEDING CONDUIT OR BASE LOCATIONS MARKED.
- BASES INSTALLED IN TERRACE SHALL BE 4' FROM FACE OF CURB UNLESS OTHERWISE NOTED. SUBJECT TO NOTE 1 ABOVE.
- THE CONTRACTOR SHALL DO ALL WORK IN ACCORDANCE WITH "CITY OF MADISON STANDARD SPECIFICATIONS FOR PUBLIC WORKS CONSTRUCTION, 2016 EDITION" AND ALL ADDENDUMS THERETO. ALL CONDUIT SHALL BE PVC, SCHEDULE 80 UNDER PAVEMENT OR SCHEDULE 40 OTHERWISE. PULL WIRE REQUIRED AS PER STANDARD SPECIFICATIONS.
- THE CONTRACTOR SHALL CALL MIKE CHRISTOPH (266-9031) AT THE TRAFFIC ENGINEERING SHOP AT LEAST 24-HOURS IN ADVANCE OF POURING BASES OR BURYING CONDUIT TO ARRANGE FOR INSPECTION. ANY WORK COMPLETED WITHOUT INSPECTION IS SUBJECT TO REJECTION.
- THE CONTRACTOR SHALL ARRANGE FOR PICK UP OF THE FOLLOWING CITY FURNISHED MATERIALS, WHICH SHOULD BE ARRANGED FOR PICKUP BY CALLING DENNIS ROWE, TRAFFIC ENGINEERING SHOP, 266-9034, 1120 SAYLE ST, AT LEAST 24-HOURS PRIOR TO NEEDING MATERIALS:
 - 3/4"X19" ANCHOR BOLTS: 1 SET OF 4
 - 1"X40" ANCHOR BOLTS: 24 SETS OF 4
 - 1-1/4"X48" ANCHOR BOLTS: 4 SETS OF 4

PLOT SCALE:

PLOT NAME:

REV. DATE:

ORIGINATOR: CITY OF MADISON, TRAFFIC ENG. DIV.

| LEGEND | |
|--------|---------------------------------------------------------|
| | INSTALL PVC (2" UNLESS OTHERWISE NOTED) |
| | TRAFFIC CONTROLLER BASE (TYPE P UNLESS OTHERWISE NOTED) |
| | TYPE G BASE |
| | TYPE IO BASE |
| | TYPE LB-3 BASE (UNLESS OTHERWISE NOTED) |
| | ELECTRICAL HANDHOLE TYPE 1 |
| | ELECTRICAL HANDHOLE TYPE 3 |
| | ELECTRICAL HANDHOLE TYPE 5 |
| | ELECTRICAL HANDHOLE TYPE 7 |
| | EXISTING ELECTRICAL HANDHOLE |
| | EXISTING SIGNAL CONTROL BASE |
| | EXISTING STREET LIGHT |
| | EXISTING SIGNAL BASE |
| | EXISTING ELECTRICAL CONDUIT |

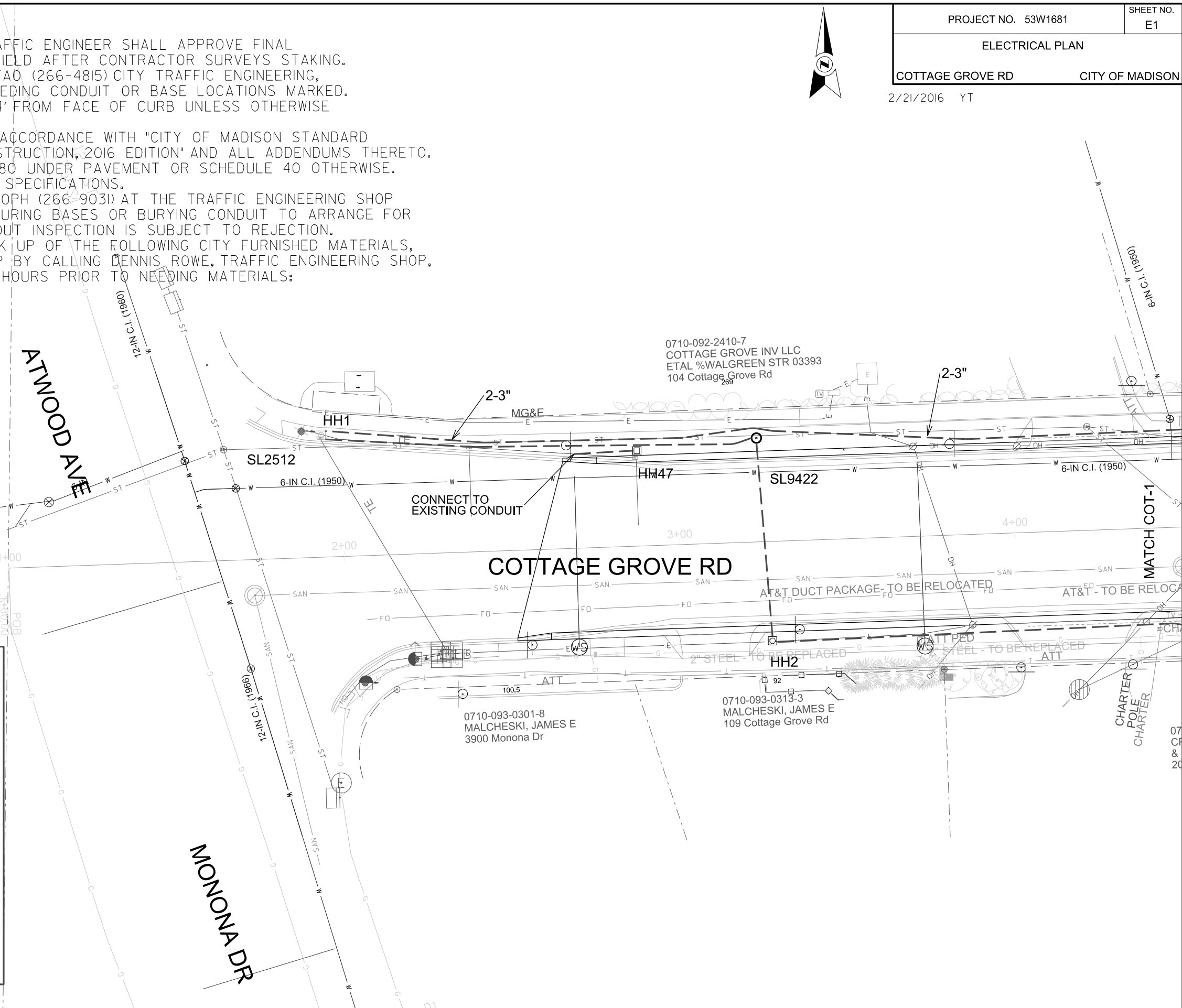



0710-092-2315-9
SUNDIAL CAPITAL LLC
C&P CAPITAL LLC
216 Cottage Grove Rd

0710-092-1801-9
SCHMIEDLIN, WAYNE & KATH
220 Cottage Grove Rd

0710-092-2314-1
SUNDIAL CAPITAL LLC
C&P CAPITAL LLC
208 Cottage Grove Rd

COTTAGE GROVE RD

JOHNS ST

0710-093-0312-5
CP STERN LLC
& STAR INVESTMENTS LLC
209 Cottage Grove Rd

0710-093-0312-5
CP STERN LLC
& STAR INVESTMENTS LLC
209 Cottage Grove Rd

LEGEND

- INSTALL PVC (2" UNLESS OTHERWISE NOTED)
- ⊗ TRAFFIC CONTROLLER BASE (TYPE P UNLESS OTHERWISE NOTED)
- ⬡ TYPE G BASE
- ⚙ TYPE IO BASE
- ⊙ TYPE LB-3 BASE (UNLESS OTHERWISE NOTED)
- ⊠ ELECTRICAL HANDHOLE TYPE 1
- ⊡ ELECTRICAL HANDHOLE TYPE 3
- ⊣ ELECTRICAL HANDHOLE TYPE 5
- ⊤ ELECTRICAL HANDHOLE TYPE 7
- ⊚ EXISTING ELECTRICAL HANDHOLE
- ⊞ EXISTING SIGNAL CONTROL BASE
- ⊛ EXISTING STREET LIGHT
- ⬤ EXISTING SIGNAL BASE
- - - EXISTING ELECTRICAL CONDUIT

PLOT SCALE:
PLOT NAME:
REV. DATE:
ORIGINATOR: CITY OF MADISON, TRAFFIC ENG. DIV.

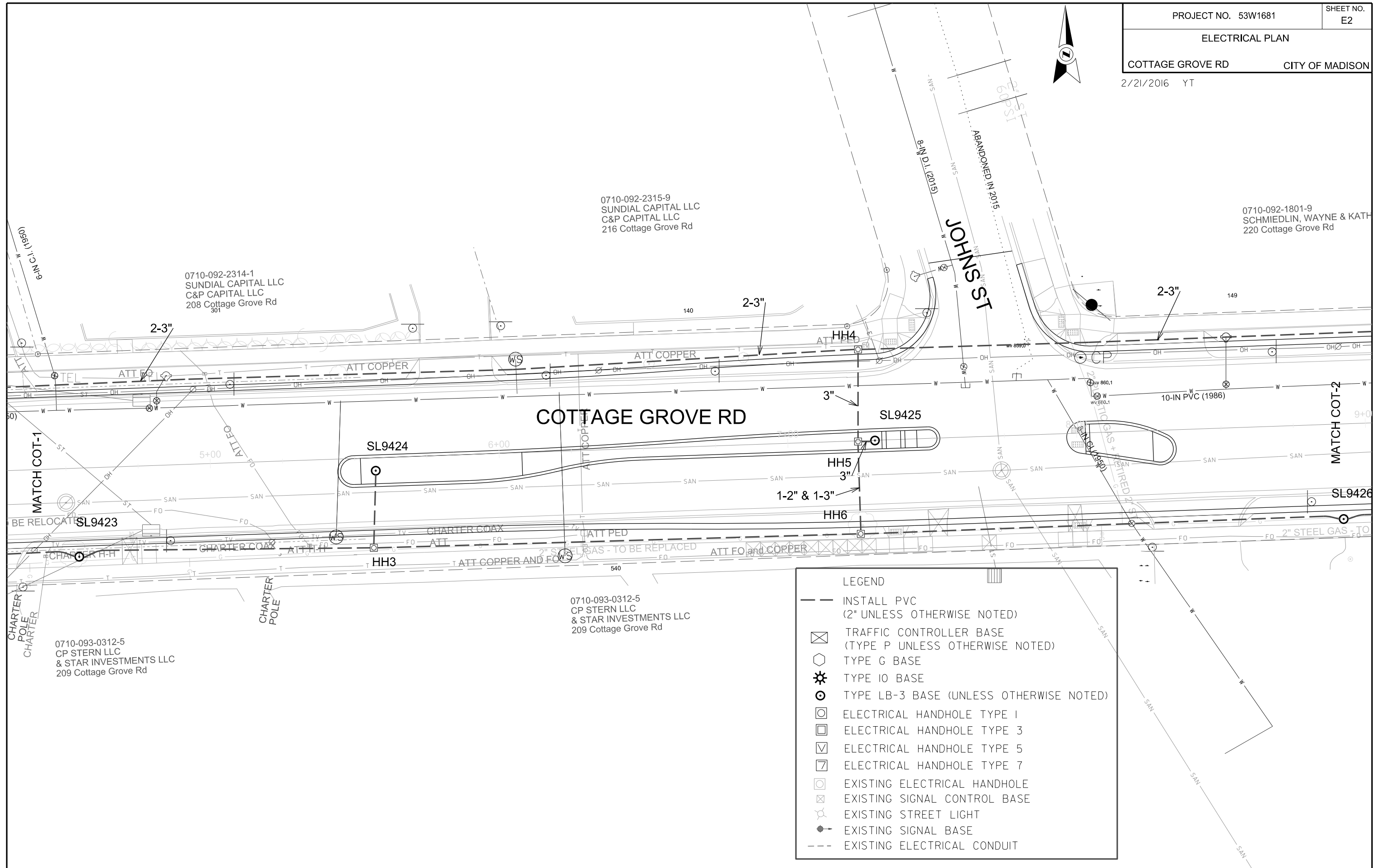

ELECTRICAL PLAN

COTTAGE GROVE RD CITY OF MADISON

2/21/2016 YT
7/6/2016 JLS

0710-092-1728-5
MADISON GAS & ELECTRIC CO
310 Cottage Grove Rd

0710-092-1725-1
MASON REAL ESTATE
HOLDINGS LLC
300 Cottage Grove Rd

0710-092-1725-1
MASON REAL ESTATE
HOLDINGS LLC
300 Cottage Grove Rd

0710-093-0314-1
HOEY PROPERTIES-MADISON
LLC
217 Cottage Grove Rd

0710-093-0307-6
VFW POST 7591
DONALD & GALEN DAY
301 Cottage Grove Rd

0710-093-0307-6
VFW POST 7591
DONALD & GALEN DAY
301 Cottage Grove Rd

0710-093-0310-9
KREHL, ESTHER
3902 Drexel Ave

7/6/2016 REVISION:
HH8 INSTALLED APPROXIMATELY 4' EAST OF PLANNED LOCATION.
MOVE SL 9427 TO STA 10+47.77, R 1.2'
INSTALL 3" PVC CONDUIT BETWEEN HH 8 AND SL 9427
INSTALL TYPE 3 HANDHOLE STA 10+32.2, R 2.5'.

| LEGEND | |
|--------|---------------------------------------------------------|
| | INSTALL PVC (2" UNLESS OTHERWISE NOTED) |
| | TRAFFIC CONTROLLER BASE (TYPE P UNLESS OTHERWISE NOTED) |
| | TYPE G BASE |
| | TYPE IO BASE |
| | TYPE LB-31 BASE (UNLESS OTHERWISE NOTED) |
| | ELECTRICAL HANDHOLE TYPE 1 |
| | ELECTRICAL HANDHOLE TYPE 3 |
| | ELECTRICAL HANDHOLE TYPE 5 |
| | ELECTRICAL HANDHOLE TYPE 7 |
| | EXISTING ELECTRICAL HANDHOLE |
| | EXISTING SIGNAL CONTROL BASE |
| | EXISTING STREET LIGHT |
| | EXISTING SIGNAL BASE |
| | EXISTING ELECTRICAL CONDUIT |

PLOT SCALE:
PLOT NAME:
REV. DATE:
ORIGINATOR: CITY OF MADISON, TRAFFIC ENG. DIV.

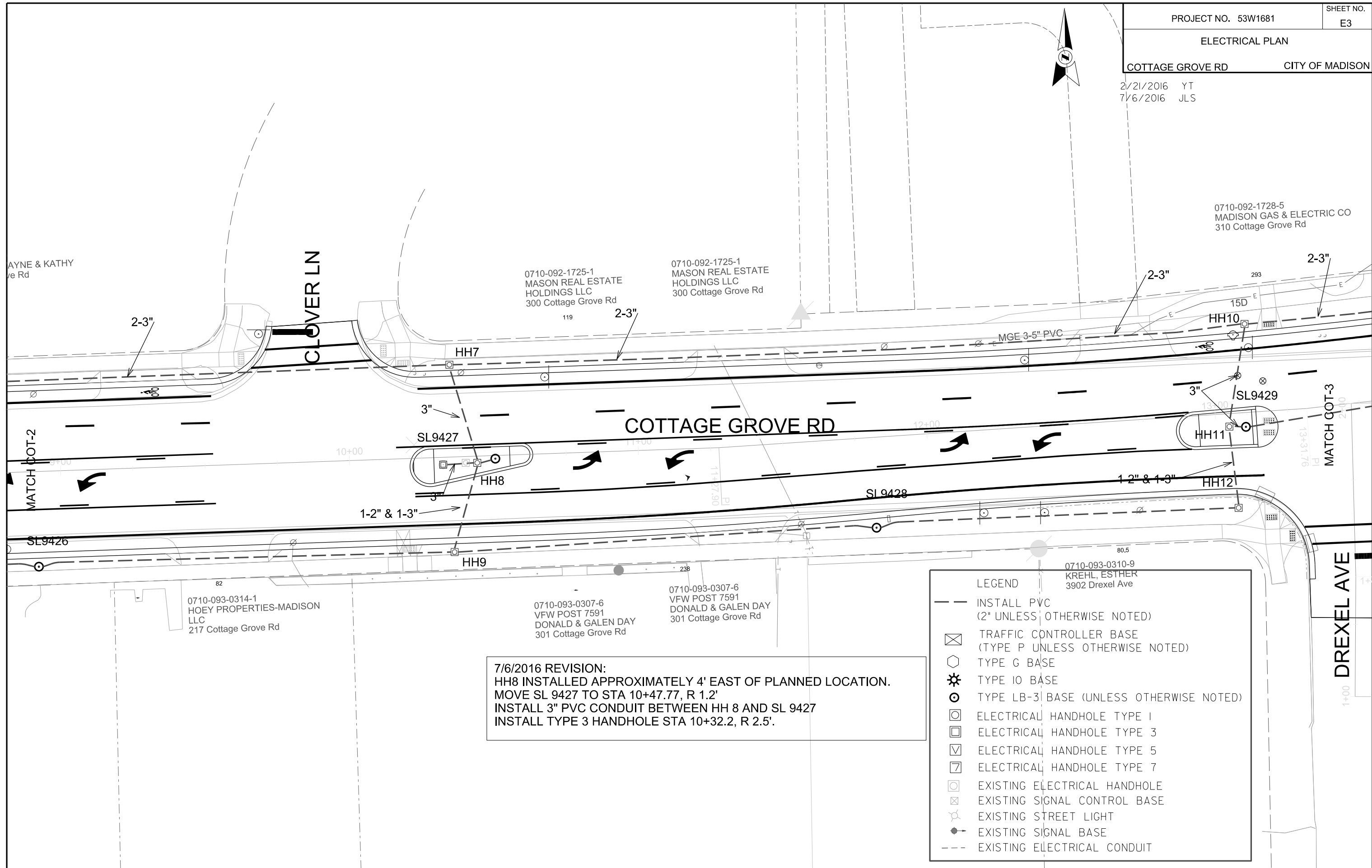

ELECTRICAL PLAN

COTTAGE GROVE RD CITY OF MADISON

LEGEND

- INSTALL PVC (2" UNLESS OTHERWISE NOTED)
- ⊠ TRAFFIC CONTROLLER BASE (TYPE P UNLESS OTHERWISE NOTED)
- ⬡ TYPE G BASE
- ⚙ TYPE IO BASE
- ⊙ TYPE LB-3 BASE (UNLESS OTHERWISE NOTED)
- ⊠ ELECTRICAL HANDHOLE TYPE 1
- ⊠ ELECTRICAL HANDHOLE TYPE 3
- ⊠ ELECTRICAL HANDHOLE TYPE 5
- ⊠ ELECTRICAL HANDHOLE TYPE 7
- ⊠ EXISTING ELECTRICAL HANDHOLE
- ⊠ EXISTING SIGNAL CONTROL BASE
- ⚡ EXISTING STREET LIGHT
- ⬠ EXISTING SIGNAL BASE
- - - EXISTING ELECTRICAL CONDUIT

0710-092-1727-7
926 ROYSTER OAKS DRIVE
RDC DEVELOPMENT LLC

0710-092-1727-7
926 ROYSTER OAKS DRIVE
RDC DEVELOPMENT LLC

0710-093-0208-6
RIPPLE FAMILY LIMITED PARTNERSHIP
401 Cottage Grove Rd

0710-093-0207-8
NOTARGIOVANNI, PATRICK & T MARGARET NOTARGIOVANNI
405 Cottage Grove Rd

0710-093-0206-0
MARON I LLC
409 Cottage Grove Rd

0710-093-0205-2
MEIER, BRIAN
MEKEL WIEDERHOLT MEIER
3901 Maher Ave

DREXEL AVE

MAHER AVE

COTTAGE GROVE RD

ROYSTER OAKS DR

LOT 7

LOT 4



PLOT SCALE:

PLOT NAME:

REV. DATE:

ORIGINATOR: CITY OF MADISON, TRAFFIC ENG. DIV.

ELECTRICAL PLAN

COTTAGE GROVE RD CITY OF MADISON

2/21/2016 YT



LEGEND

- INSTALL PVC (2" UNLESS OTHERWISE NOTED)
- ⊠ TRAFFIC CONTROLLER BASE (TYPE P UNLESS OTHERWISE NOTED)
- ⬡ TYPE G BASE
- ⊛ TYPE IO BASE
- ⊙ TYPE LB-3 BASE (UNLESS OTHERWISE NOTED)
- ⊕ ELECTRICAL HANDHOLE TYPE 1
- ⊞ ELECTRICAL HANDHOLE TYPE 3
- ⊟ ELECTRICAL HANDHOLE TYPE 5
- ⊠ ELECTRICAL HANDHOLE TYPE 7
- ⊕ EXISTING ELECTRICAL HANDHOLE
- ⊠ EXISTING SIGNAL CONTROL BASE
- ⊙ EXISTING STREET LIGHT
- ⊙ EXISTING SIGNAL BASE
- - - EXISTING ELECTRICAL CONDUIT

PLOT SCALE:

PLOT SCALE:

PLOT NAME:

REV. DATE:

ORIGINATOR: CITY OF MADISON, TRAFFIC ENG. DIV.

LOT 4

0710-092-2704-4
RDC DEVELOPMENT LLC
502 Cottage Grove Rd

0710-092-2703-6
RDC DEVELOPMENT LLC
516 Cottage Grove Rd

0710-092-2703-6
RDC DEVELOPMENT LLC
516 Cottage Grove Rd

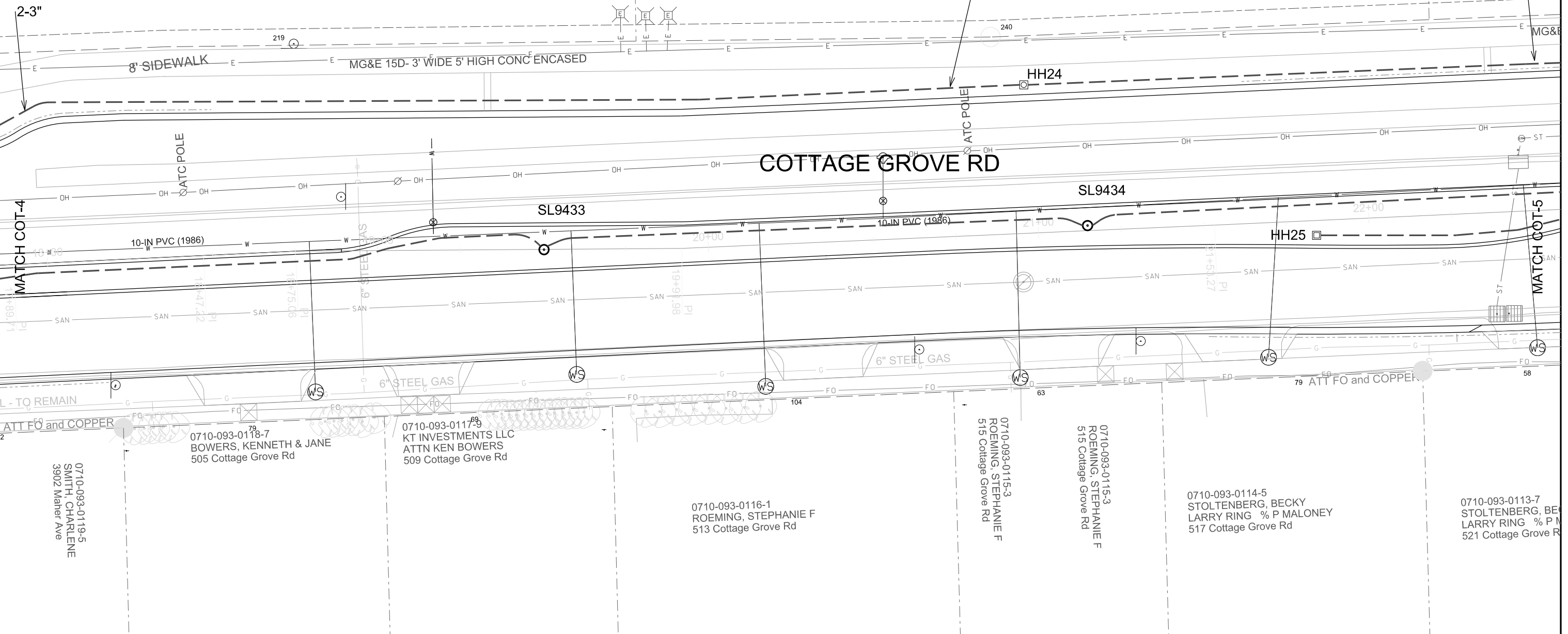

0710-092-2702-8
RDC DEVELOPMENT LLC
530 Cottage Grove Rd

PROJECT NO. 53W1681

SHEET NO.
E6

ELECTRICAL PLAN

COTTAGE GROVE RD CITY OF MADISON

2/21/2016 YT

BRING EXISTING 3" CONDUITS
ALONG COTTAGE GROVE
TO HANDHOLE

COTTAGE GROVE RD

DEMPSEY RD

LEGEND

- INSTALL PVC (2" UNLESS OTHERWISE NOTED)
- ⊗ TRAFFIC CONTROLLER BASE (TYPE P UNLESS OTHERWISE NOTED)
- ⬡ TYPE G BASE
- ⊙ TYPE IO BASE
- ⊙ TYPE LB-3 BASE (UNLESS OTHERWISE NOTED)
- ⊙ ELECTRICAL HANDHOLE TYPE 1
- ⊙ ELECTRICAL HANDHOLE TYPE 3
- ⊙ ELECTRICAL HANDHOLE TYPE 5
- ⊙ ELECTRICAL HANDHOLE TYPE 7
- ⊙ EXISTING ELECTRICAL HANDHOLE
- ⊙ EXISTING SIGNAL CONTROL BASE
- ⊙ EXISTING STREET LIGHT
- ⊙ EXISTING SIGNAL BASE
- - - EXISTING ELECTRICAL CONDUIT

PLOT SCALE:
PLOT NAME:
REV. DATE:
ORIGINATOR: CITY OF MADISON, TRAFFIC ENG. DIV.

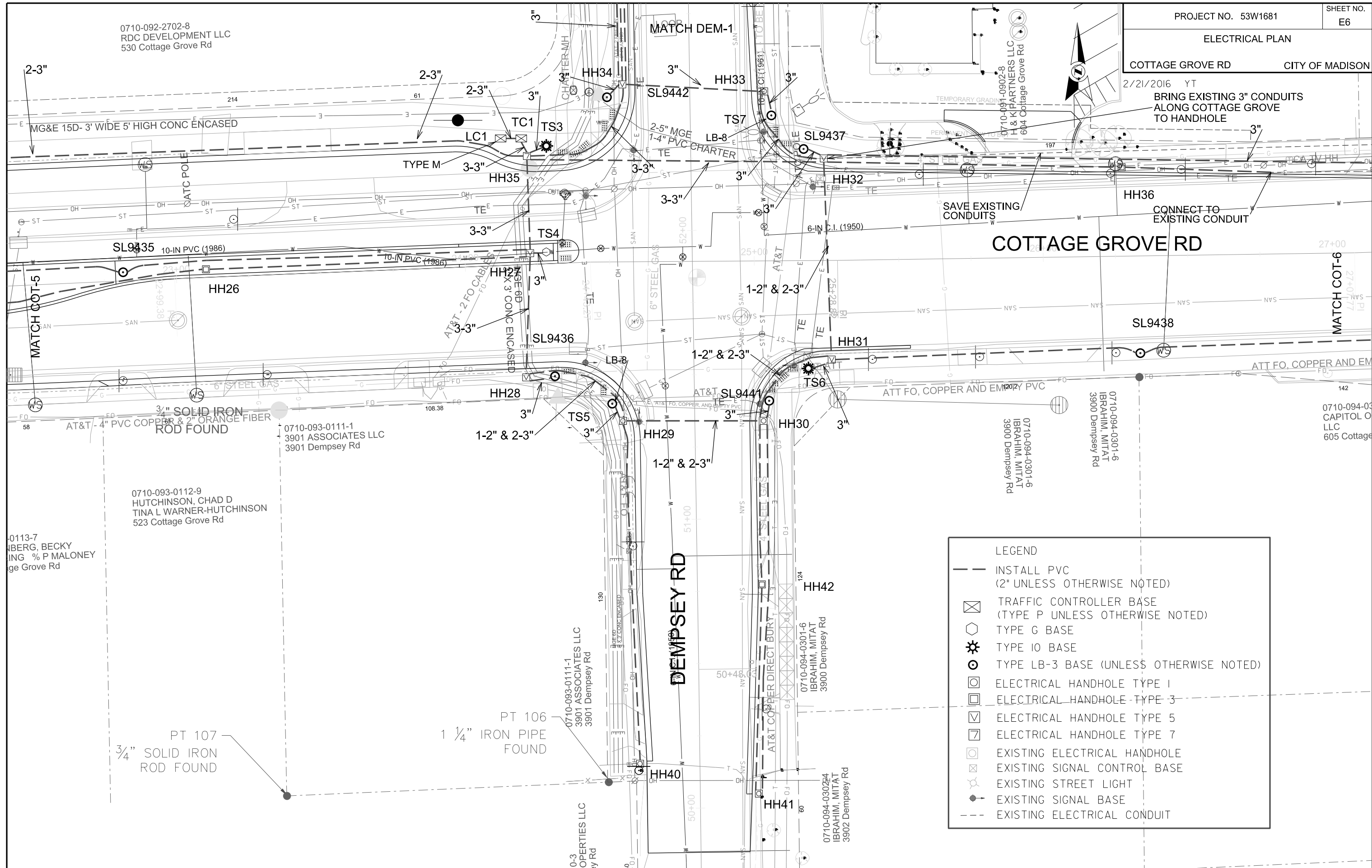



LEGEND

- INSTALL PVC (2" UNLESS OTHERWISE NOTED)
- ⊠ TRAFFIC CONTROLLER BASE (TYPE P UNLESS OTHERWISE NOTED)
- ⬡ TYPE G BASE
- ⚙ TYPE IO BASE
- ⊙ TYPE LB-3 BASE (UNLESS OTHERWISE NOTED)
- ⊕ ELECTRICAL HANDHOLE TYPE 1
- ⊞ ELECTRICAL HANDHOLE TYPE 3
- ⊟ ELECTRICAL HANDHOLE TYPE 5
- ⊠ ELECTRICAL HANDHOLE TYPE 7
- ⊕ EXISTING ELECTRICAL HANDHOLE
- ⊠ EXISTING SIGNAL CONTROL BASE
- ⚡ EXISTING STREET LIGHT
- EXISTING SIGNAL BASE
- EXISTING ELECTRICAL CONDUIT

PLOT SCALE:
PLOT NAME:
REV. DATE:
ORIGINATOR: CITY OF MADISON, TRAFFIC ENG. DIV.

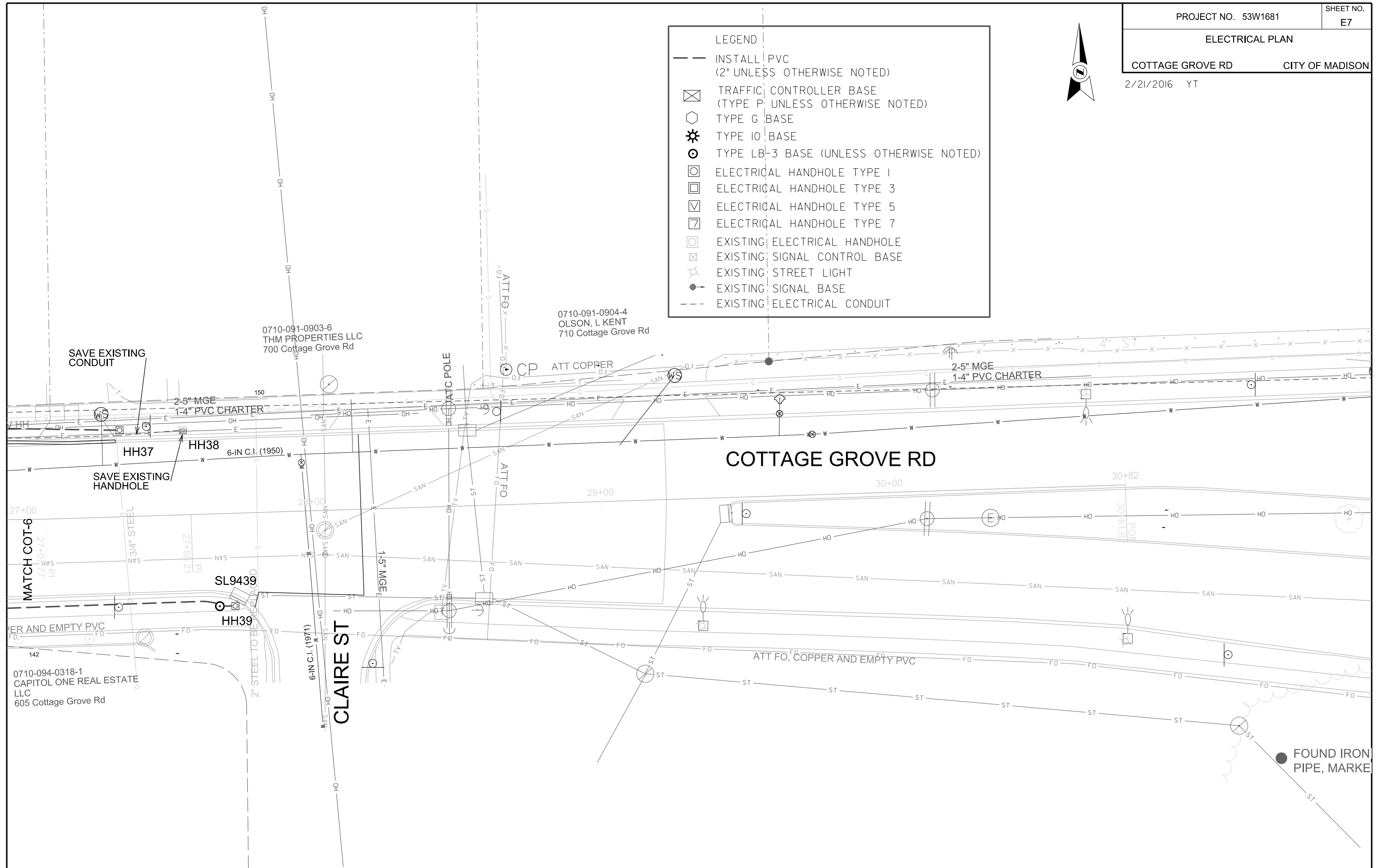

ELECTRICAL PLAN

COTTAGE GROVE RD CITY OF MADISON

2/21/2016 YT



LEGEND

- INSTALL PVC (2" UNLESS OTHERWISE NOTED)
- ⊠ TRAFFIC CONTROLLER BASE (TYPE P UNLESS OTHERWISE NOTED)
- ⬡ TYPE G BASE
- ⊙ TYPE IO BASE
- ⊙ TYPE LB-3 BASE (UNLESS OTHERWISE NOTED)
- ⊠ ELECTRICAL HANDHOLE TYPE 1
- ⊠ ELECTRICAL HANDHOLE TYPE 3
- ⊠ ELECTRICAL HANDHOLE TYPE 5
- ⊠ ELECTRICAL HANDHOLE TYPE 7
- ⊠ EXISTING ELECTRICAL HANDHOLE
- ⊠ EXISTING SIGNAL CONTROL BASE
- ⊙ EXISTING STREET LIGHT
- ⊙ EXISTING SIGNAL BASE
- - - EXISTING ELECTRICAL CONDUIT

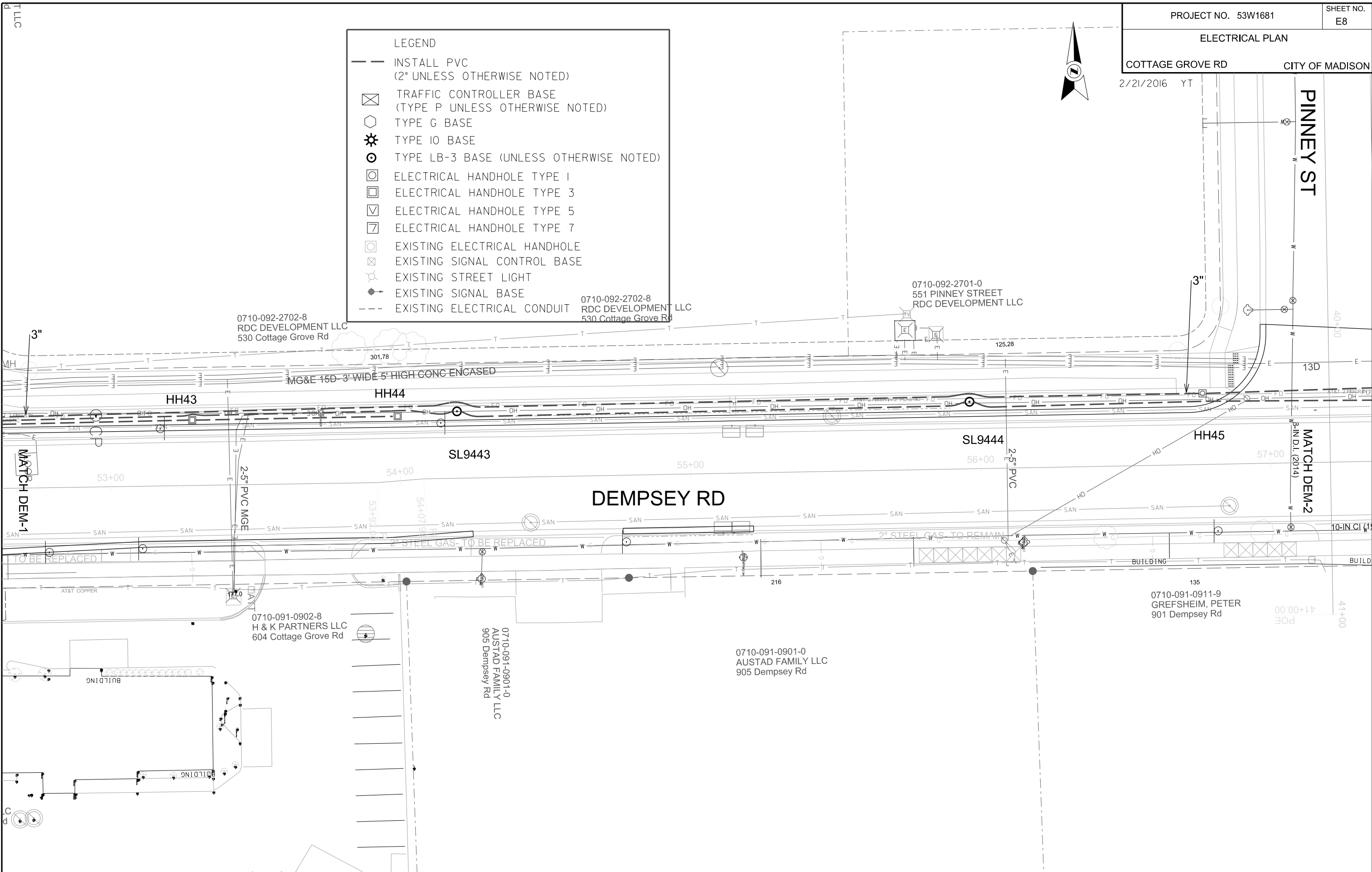

PLOT SCALE:

PLOT NAME:

REV. DATE:

ORIGINATOR: CITY OF MADISON, TRAFFIC ENG. DIV.

ELECTRICAL PLAN

COTTAGE GROVE RD CITY OF MADISON

2/21/2016 YT



LEGEND

- INSTALL PVC (2" UNLESS OTHERWISE NOTED)
- ⊠ TRAFFIC CONTROLLER BASE (TYPE P UNLESS OTHERWISE NOTED)
- ⬡ TYPE G BASE
- ⊙ TYPE IO BASE
- ⊙ TYPE LB-3 BASE (UNLESS OTHERWISE NOTED)
- ⊙ ELECTRICAL HANDHOLE TYPE 1
- ⊙ ELECTRICAL HANDHOLE TYPE 3
- ⊙ ELECTRICAL HANDHOLE TYPE 5
- ⊙ ELECTRICAL HANDHOLE TYPE 7
- ⊙ EXISTING ELECTRICAL HANDHOLE
- ⊙ EXISTING SIGNAL CONTROL BASE
- ⊙ EXISTING STREET LIGHT
- ⊙ EXISTING SIGNAL BASE
- EXISTING ELECTRICAL CONDUIT

0710-092-2520-4
526 PINNEY STREET
RDC DEVELOPMENT LLC

PLOT SCALE:
PLOT NAME:
REV. DATE:
ORIGINATOR: CITY OF MADISON, TRAFFIC ENG. DIV.

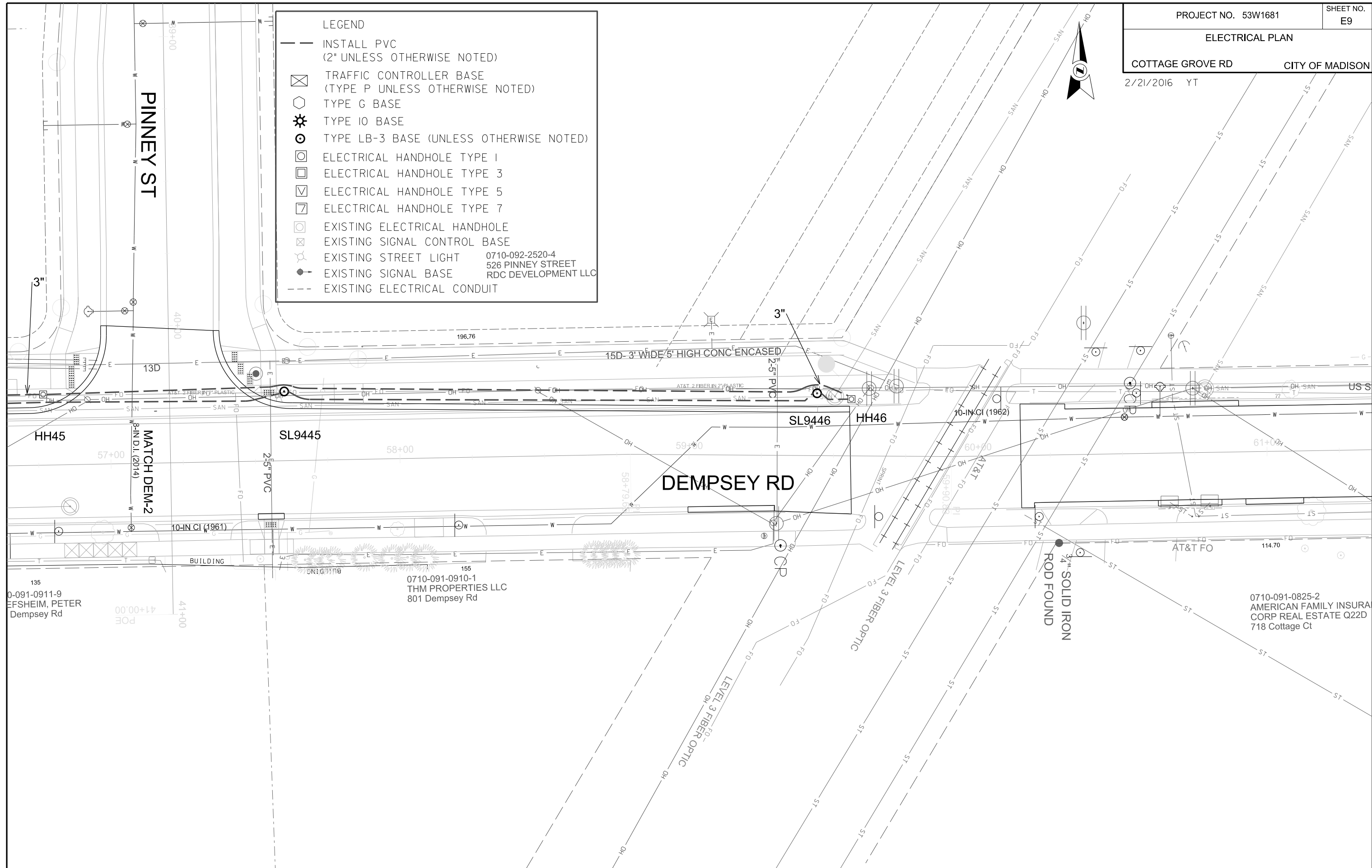

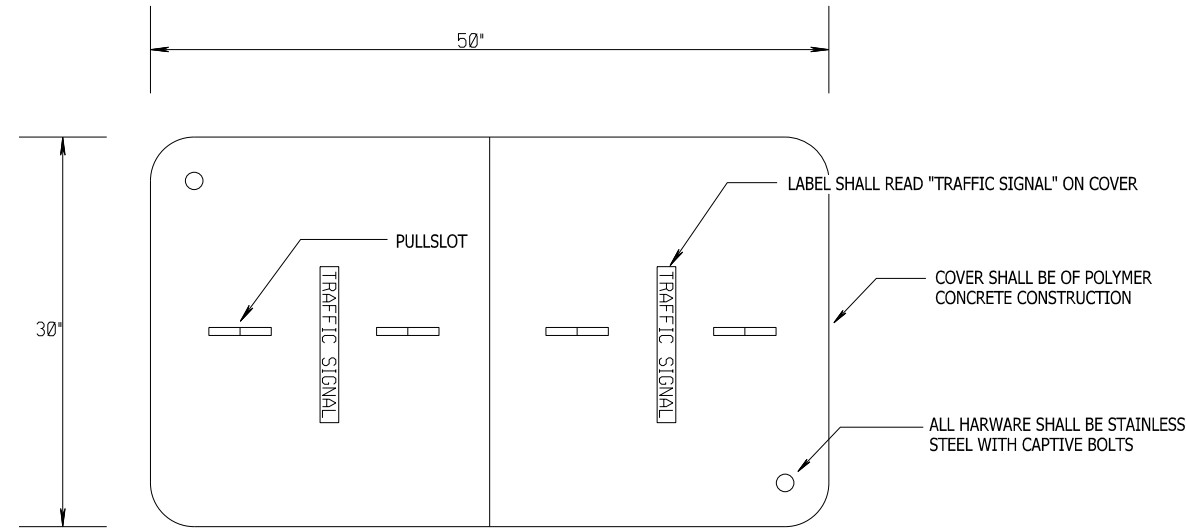

•15,000 LBS MAXIMUM LOAD OVER A 10'X10' TEST AREA RATING FOR COVER AND BOX

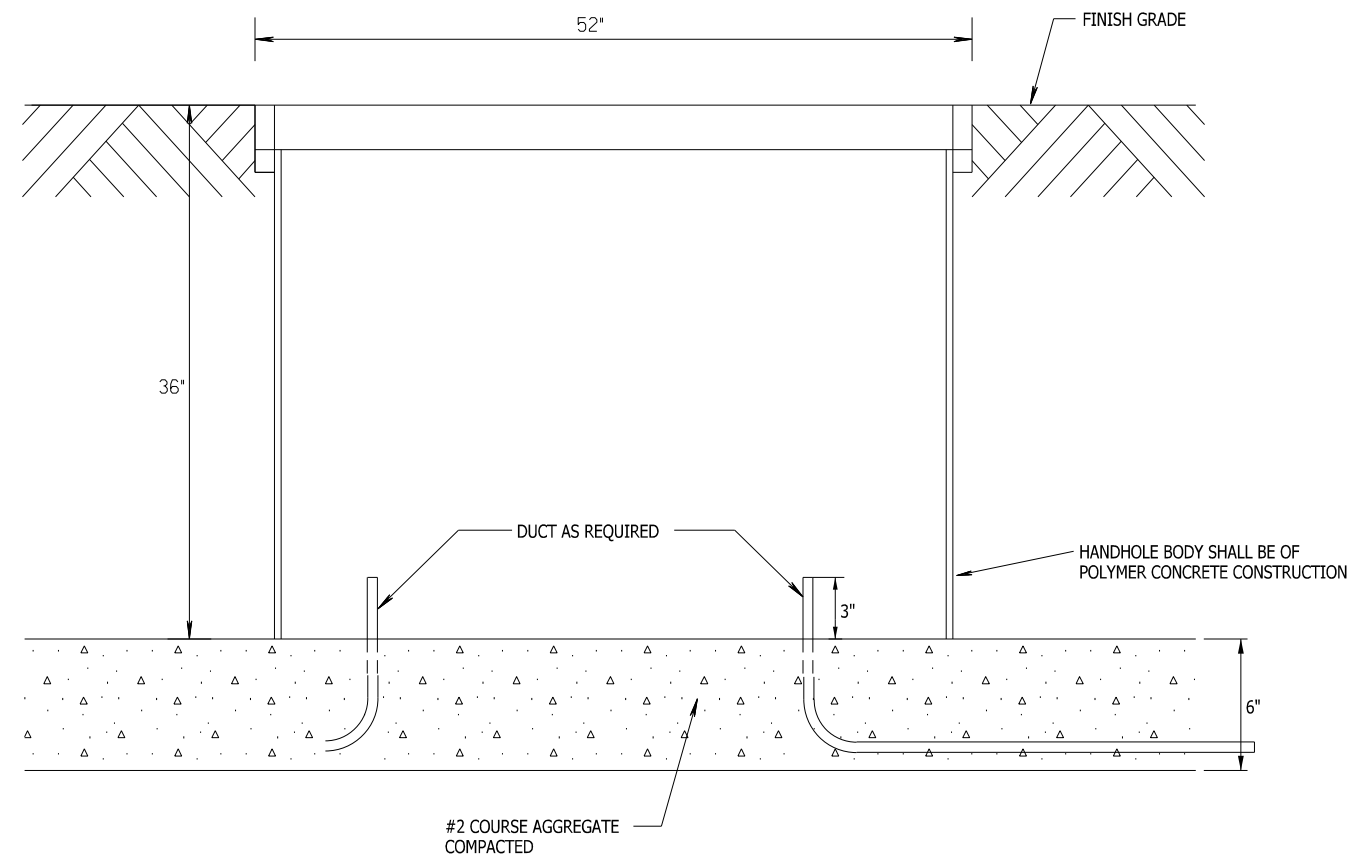

TYPE 7 HANDHOLE
DETAIL

PLOT SCALE:

PLOT NAME:

REV. DATE:

ORIGINATOR: CITY OF MADISON, TRAFFIC ENG. DIV.

GENERAL NOTES

DETAILS OF CONSTRUCTION, MATERIALS AND WORKMANSHIP NOT SHOWN ON THIS DRAWING SHALL CONFORM TO THE PERTINENT REQUIREMENTS OF THE CONTRACT.

BASES SHALL BE EXCAVATED BY USE OF A CIRCULAR AUGER.

TOP SURFACES OF CONCRETE BASES SHALL BE TROWEL FINISHED AND LEVEL.

CONDUIT SIZES AND LOCATIONS SHALL BE AS SHOWN ON THE PLANS.

THE FINAL OR TERMINATING CONCRETE BASE IN A CONDUIT RUN SHALL HAVE A 6" EXIT STUB INSTALLED FOR FUTURE CABLING USE. THE EXIT STUB SHALL BE SIZED AS USED THROUGHOUT THE CONDUIT RUN AS SHOWN AT THE ENTRANCE OF THE BASE.

MINIMUM BENDING RADIUS OF CONDUIT IS EQUAL TO 6 X THE DIAMETER.

CONDUIT HEIGHT ABOVE CONCRETE BASES SHALL BE 4 INCHES. ALL METALLIC CONDUIT ENDS SHALL BE REAMED AND THREADED. NONMETALLIC CONDUIT SHALL HAVE BELL END INSTALLED. ALL CONDUIT SHALL BE SLOPED TO PULL BOX.

ALL CONDUIT ENDS AT THE TOP OF CONCRETE BASES SHALL BE CAPPED IF METALLIC OR PLUGGED IF NONMETALLIC IMMEDIATELY AFTER PLACEMENT AND BEFORE CONCRETE IS POURED. CONDUIT IN WHICH WIRE OR CABLE IS NOT INSTALLED SHALL REMAIN CAPPED OR PLUGGED.

BELL ENDS SHALL BE INSTALLED ON ALL PVC CONDUIT EXPOSED AT THE TOP OF CONCRETE BASES BEFORE INSTALLATION OF CABLE OR WIRE.

ENDS OF CONDUIT INSTALLED BELOW GRADE FOR FUTURE USE SHALL BE CAPPED IF METALLIC OR PLUGGED IF NONMETALLIC.

WHEN REQUIRED TO CONNECT NONMETALLIC CONDUIT TO METALLIC CONDUIT, ONLY ADAPTER FITTINGS, U.L. LISTED FOR ELECTRICAL USE, SHALL BE USED.

IF A BASE REQUIRES A DEEP FORM BECAUSE OF LOOSE DIRT OR FILL, THE FORM SHALL BE REMOVED BEFORE BACKFILLING AROUND THE BASE. BACKFILL SHALL BE TAMPED TIGHT AGAINST THE BARE CONCRETE BASE IN LAYERS OF 1 FOOT OR LESS.

A NO. 4 AWG, STRANDED COPPER EQUIPMENT GROUNDING CONDUCTOR SHALL BE EXOTHERMICALLY WELDED TO THE EQUIPMENT GROUNDING ELECTRODE (GROUND ROD).

THE EQUIPMENT GROUNDING CONDUCTOR SHALL ENTER THE BASE THROUGH A 1 INCH CONDUIT INSTALLED FOR GROUNDING PURPOSES, LEAVING A 4 FOOT COIL OF WIRE ABOVE THE CONCRETE BASE. THE EQUIPMENT GROUNDING CONDUCTOR SHALL BE NEATLY COILED AND THE COILS TIED TOGETHER.

WELDING OF THE ANCHOR RODS TO THE CAGE IS UNACCEPTABLE. TEMPLATES SHALL BE USED.

BAR STEEL REINFORCEMENT SHALL BE COATED WITH POWDERED EPOXY RESIN IN ACCORDANCE WITH SECTION 505 OF THE STANDARD SPECIFICATIONS (LATEST EDITION).

ANCHOR RODS SHALL BE INSTALLED WITH MISALIGNMENTS OF LESS THAN 1:40 FROM VERTICAL.

① THE MINIMUM DEPTH OF CONDUIT EXITING THE CONCRETE BASE AND INSTALLED BELOW THE TRAVELED WAY SHALL BE 24 INCHES. THE MINIMUM DEPTH OF CONDUIT EXITING THE CONCRETE BASE THAT IS NOT INSTALLED BELOW THE TRAVELED WAY SHALL BE 18 INCHES. THE MAXIMUM DEPTH OF ALL CONDUIT SHALL BE 36 INCHES, (GREATER THAN 36 INCHES IF INSTALLED IN BREAKER-RUN), EXCEPT WITH WRITTEN APPROVAL BY THE ENGINEER.

② (6) NO. 6 X 13'-7" BAR STEEL REINFORCEMENT.

③ (15) NO. 4 X 7'-4" BAR STEEL REINFORCEMENT @ 1'-0" MAX. C-C.

CONCRETE MASONRY ----- $f_c=3,500$ p.s.i.
 HIGH STRENGTH BAR STEEL REINFORCEMENT, GRADE 60 ----- $f_y=60,000$ p.s.i.
 ANCHOR RODS, AASHTO M314 GRADE 55 ----- $f_y=55,000$ p.s.i.
 TEMPLATES, ASTM, A709 GRADE 36 ----- $f_y=36,000$ p.s.i.

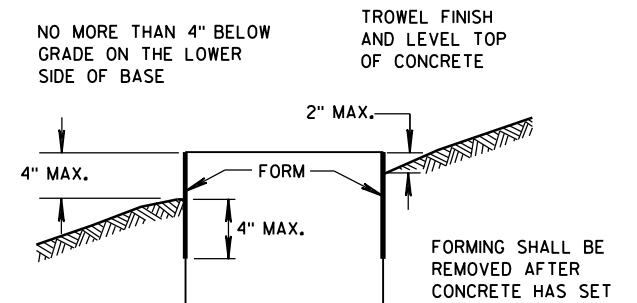
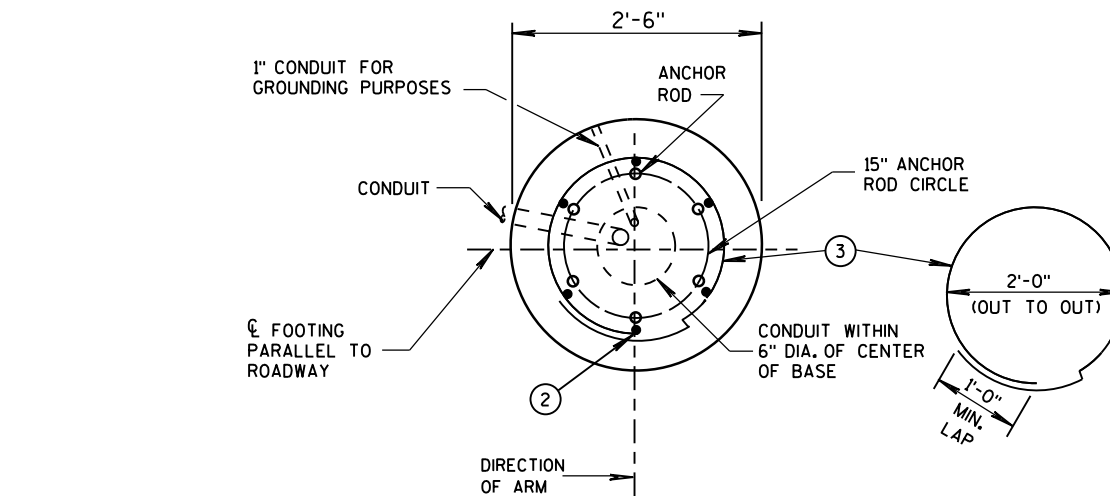

FORMING DETAIL

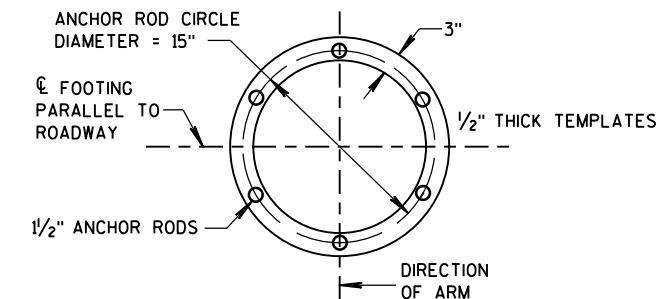

TOP AND BOTTOM TEMPLATES

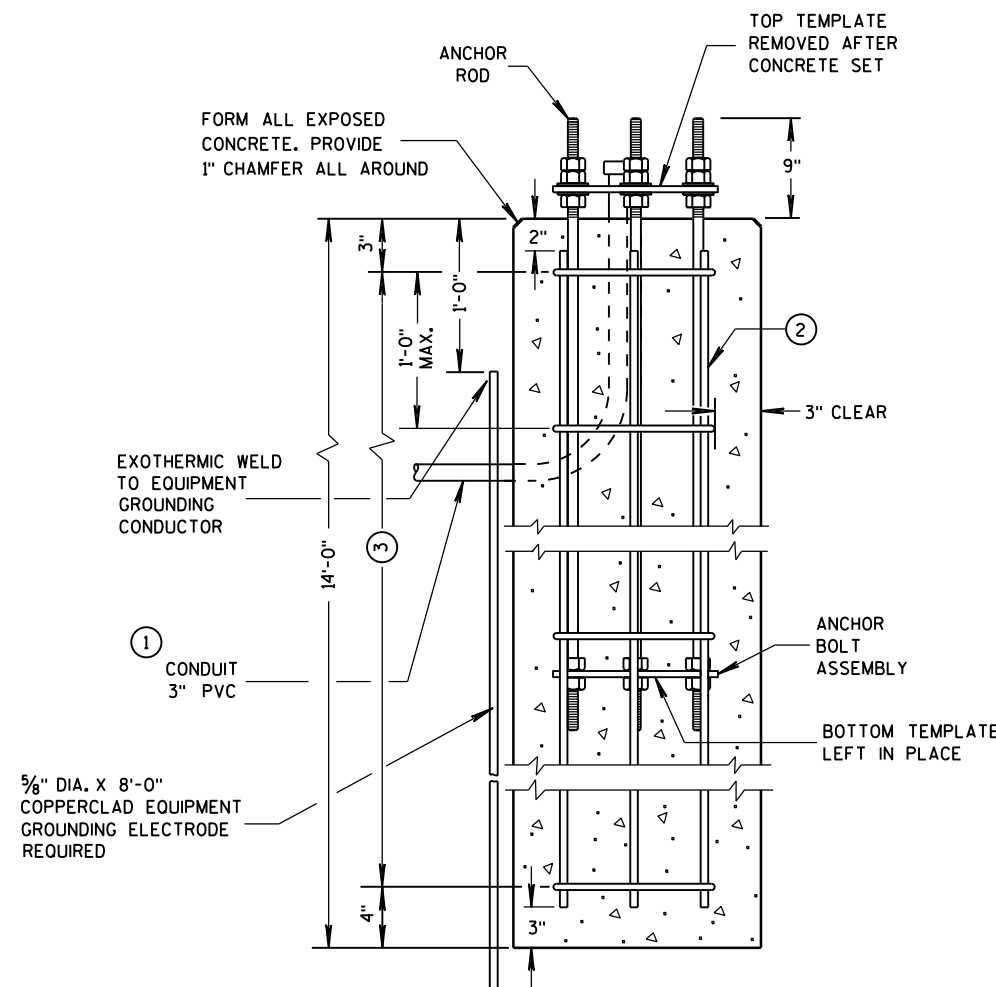

**CONCRETE BASE TYPE 10
(FOR TYPE 9 & 10 POLES)**

TO BE USED WHEN GROUND ELEVATION AT BASE EQUALS OR IS GREATER THAN HIGH POINT OF ROADWAY ELEVATION. SEE S.D.D. 9C13-2 WHEN GROUND ELEVATION AT BASE IS LOWER THAN HIGH POINT OF ROADWAY ELEVATION.

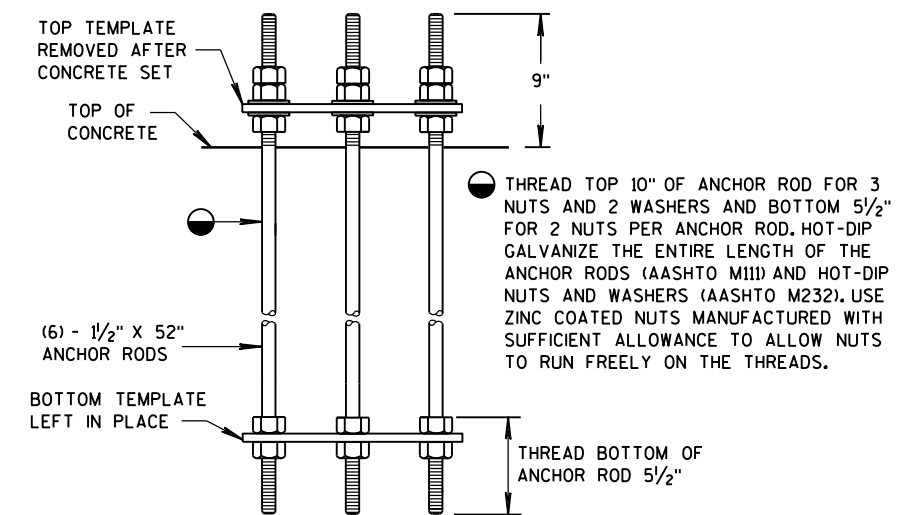

ANCHOR BOLT ASSEMBLY DETAIL

**CONCRETE BASE TYPE 10
ANCHOR ASSEMBLY**

| QUANTITY REQUIREMENTS | |
|---------------------------------|-----|
| APPROX. CUBIC YARDS OF CONCRETE | 2.5 |
| LBS. OF HOOP BAR STEEL | 69 |
| LBS. OF VERTICAL BAR STEEL | 122 |

| CONCRETE BASE TYPE 10 | |
|----------------------------------------------------|---------------------------------------------------|
| STATE OF WISCONSIN DEPARTMENT OF TRANSPORTATION | |
| APPROVED DATE | /S/ Ahmet Demirbilek STATE ELECTRICAL ENGINEER |
| FHWA | |

6

6

TRAFFIC CONTROL PLAN

PHASE 1

CITY OF MADISON

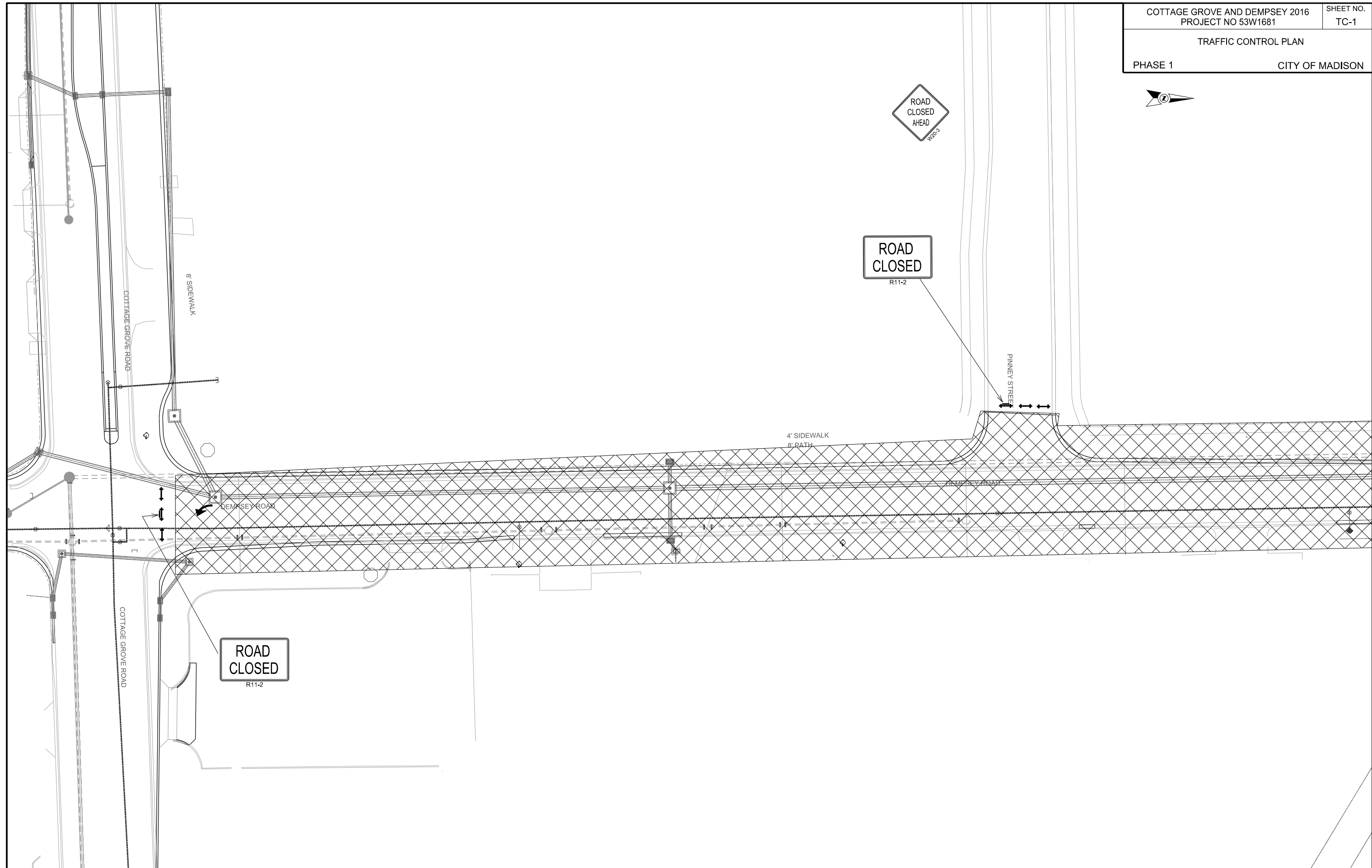

PLOT SCALE:

PLOT NAME:

REV. DATE:

ORIGINATOR: CITY OF MADISON, TRAFFIC ENG. DIV.

TRAFFIC CONTROL PLAN

PHASE 1

CITY OF MADISON

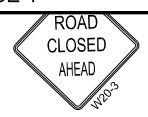

Keep into
needed if
shall not

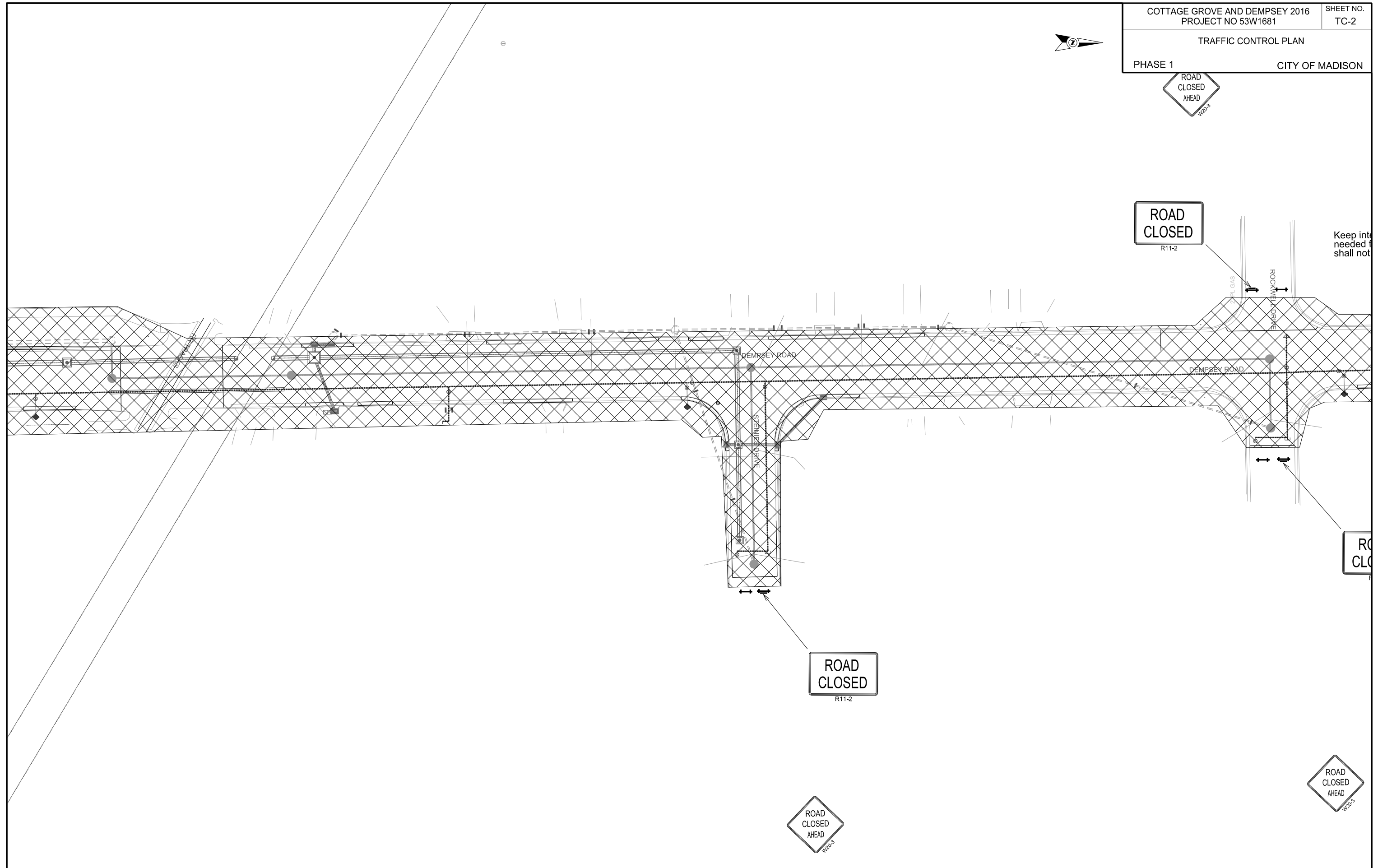

PLOT SCALE:

PLOT NAME:

REV. DATE:

ORIGINATOR: CITY OF MADISON, TRAFFIC ENG. DIV.

TRAFFIC CONTROL PLAN

PHASE 1 CITY OF MADISON



ROAD CLOSED R11-2

ROAD CLOSED R11-2

ROAD CLOSED R11-2

ROAD CLOSED R11-2

ROAD CLOSED R11-2

ROAD CLOSED R11-2



Keep intersections open at all times except when needed for construction. Rockwell Dr and Anchor Dr shall not be closed at the same time.

PLOT SCALE:
PLOT NAME:
REV. DATE:
ORIGINATOR: CITY OF MADISON, TRAFFIC ENG. DIV.

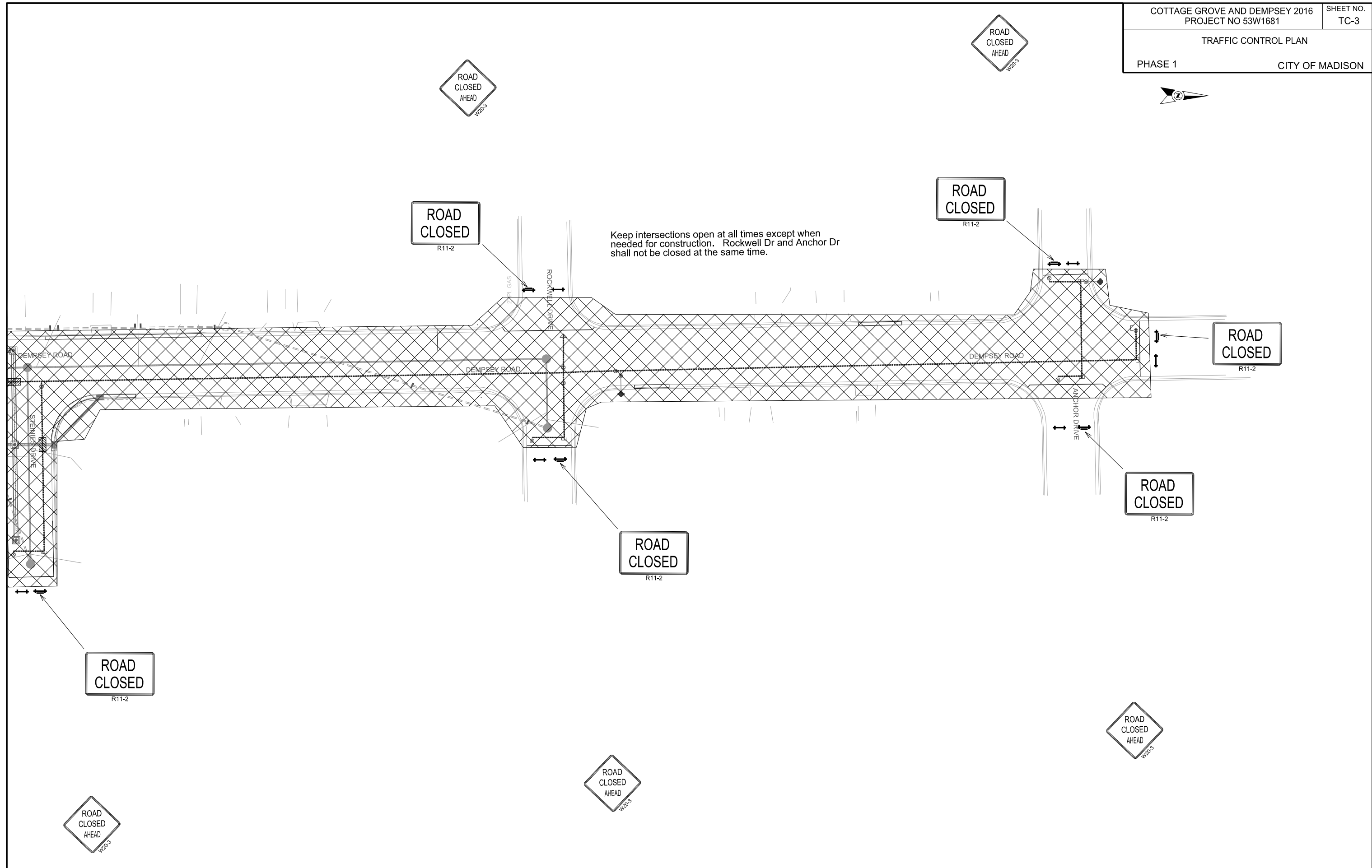



PLOT SCALE:

PLOT NAME:

REV. DATE:

ORIGINATOR: CITY OF MADISON, TRAFFIC ENG. DIV.

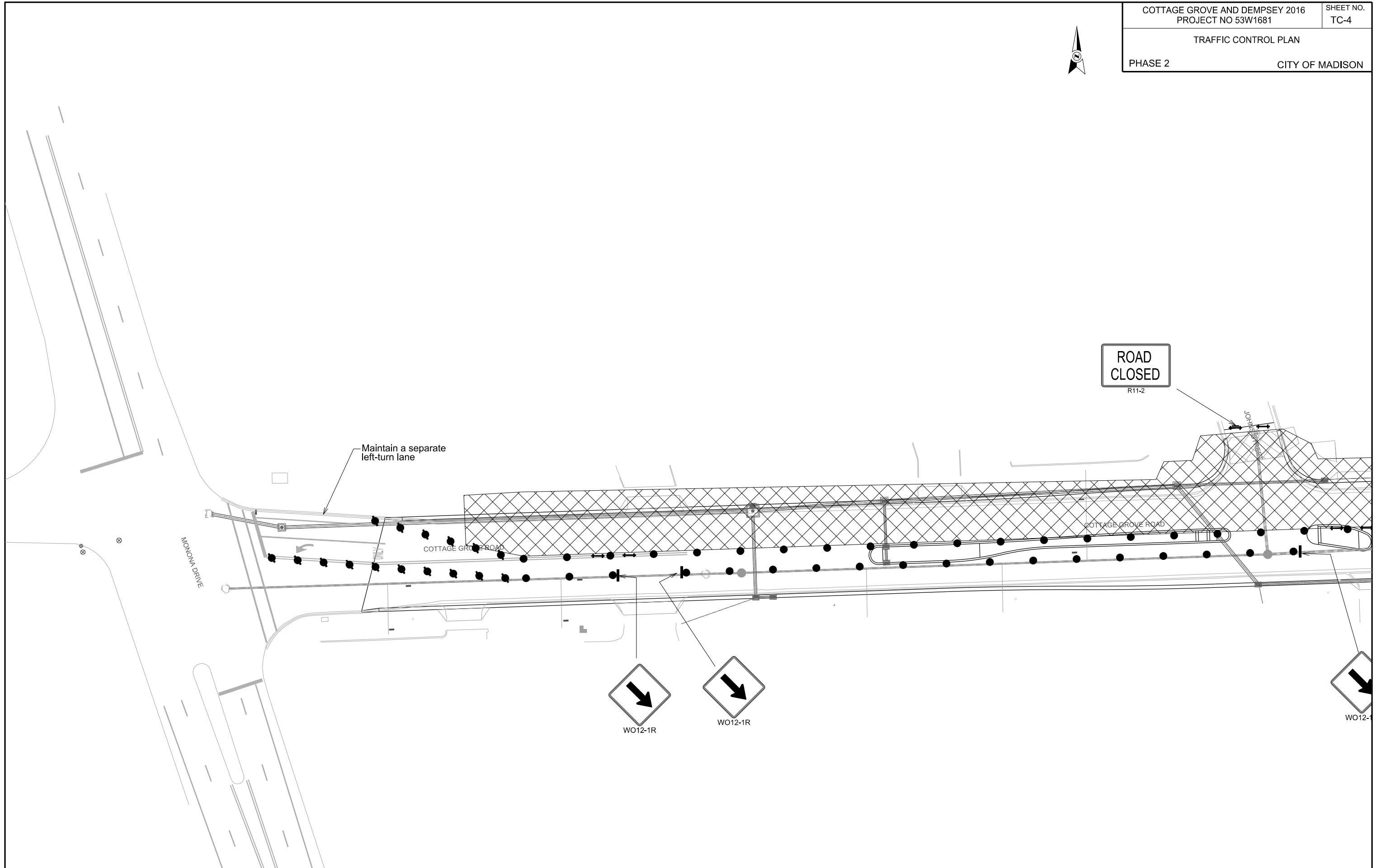



PLOT SCALE:

PLOT NAME:

REV. DATE:

ORIGINATOR: CITY OF MADISON, TRAFFIC ENG. DIV.

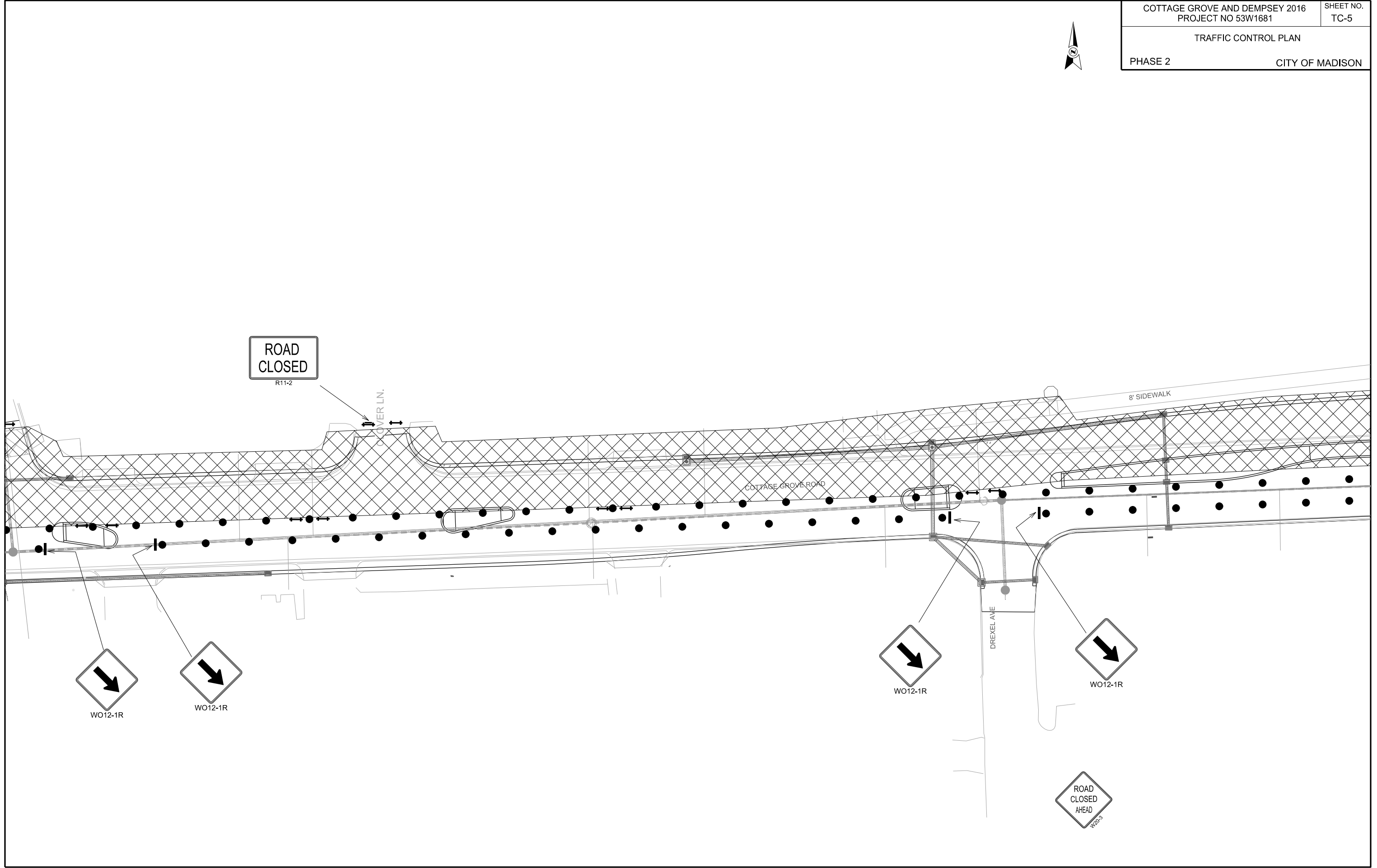



PLOT SCALE:

PLOT NAME:

REV. DATE:

ORIGINATOR: CITY OF MADISON, TRAFFIC ENG. DIV.

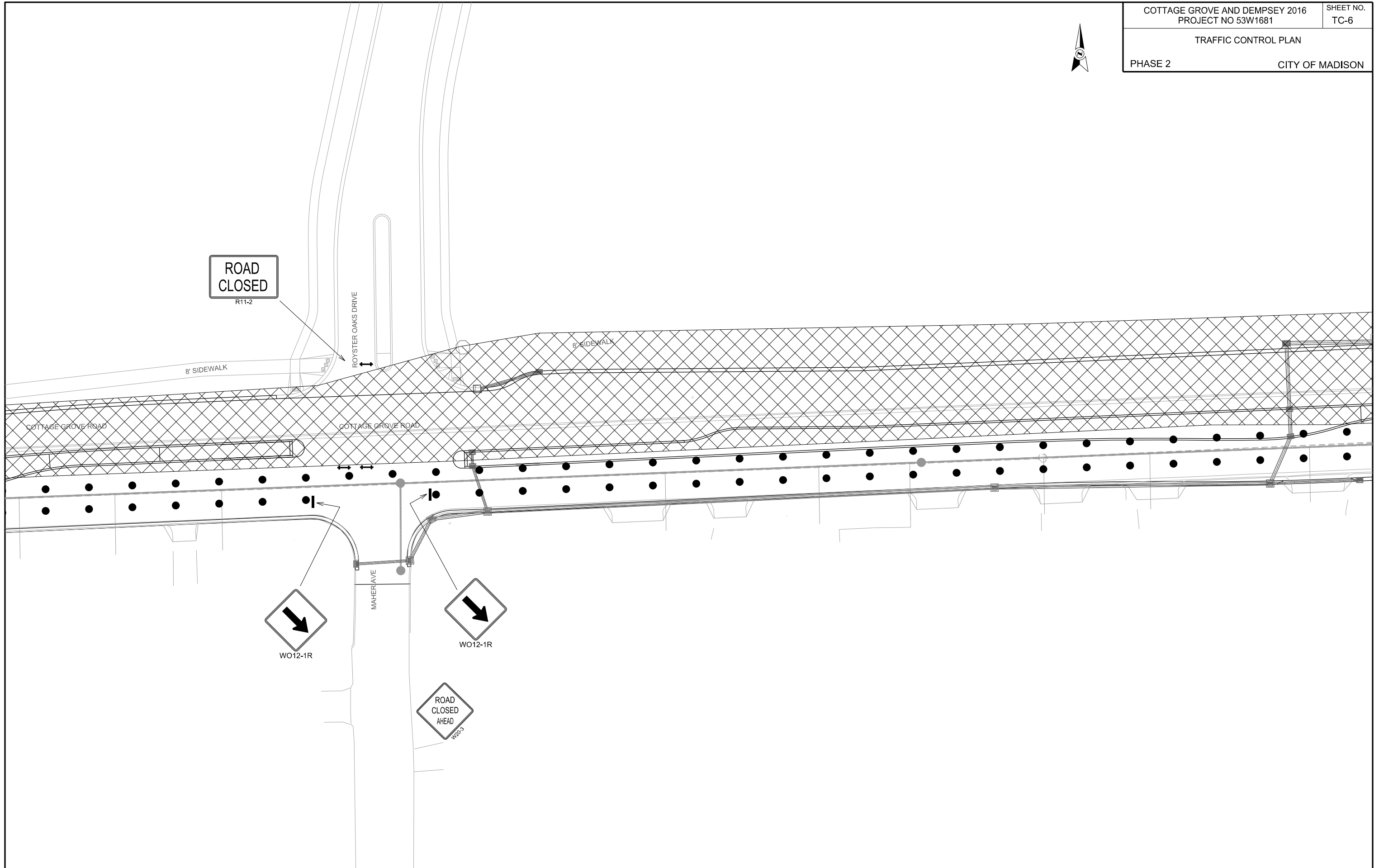

TRAFFIC CONTROL PLAN

PHASE 2

CITY OF MADISON



Signs spaced at 200' starting for first barrel

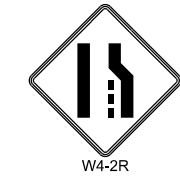

PLOT SCALE:

PLOT NAME:

REV. DATE:

ORIGINATOR: CITY OF MADISON, TRAFFIC ENG. DIV.

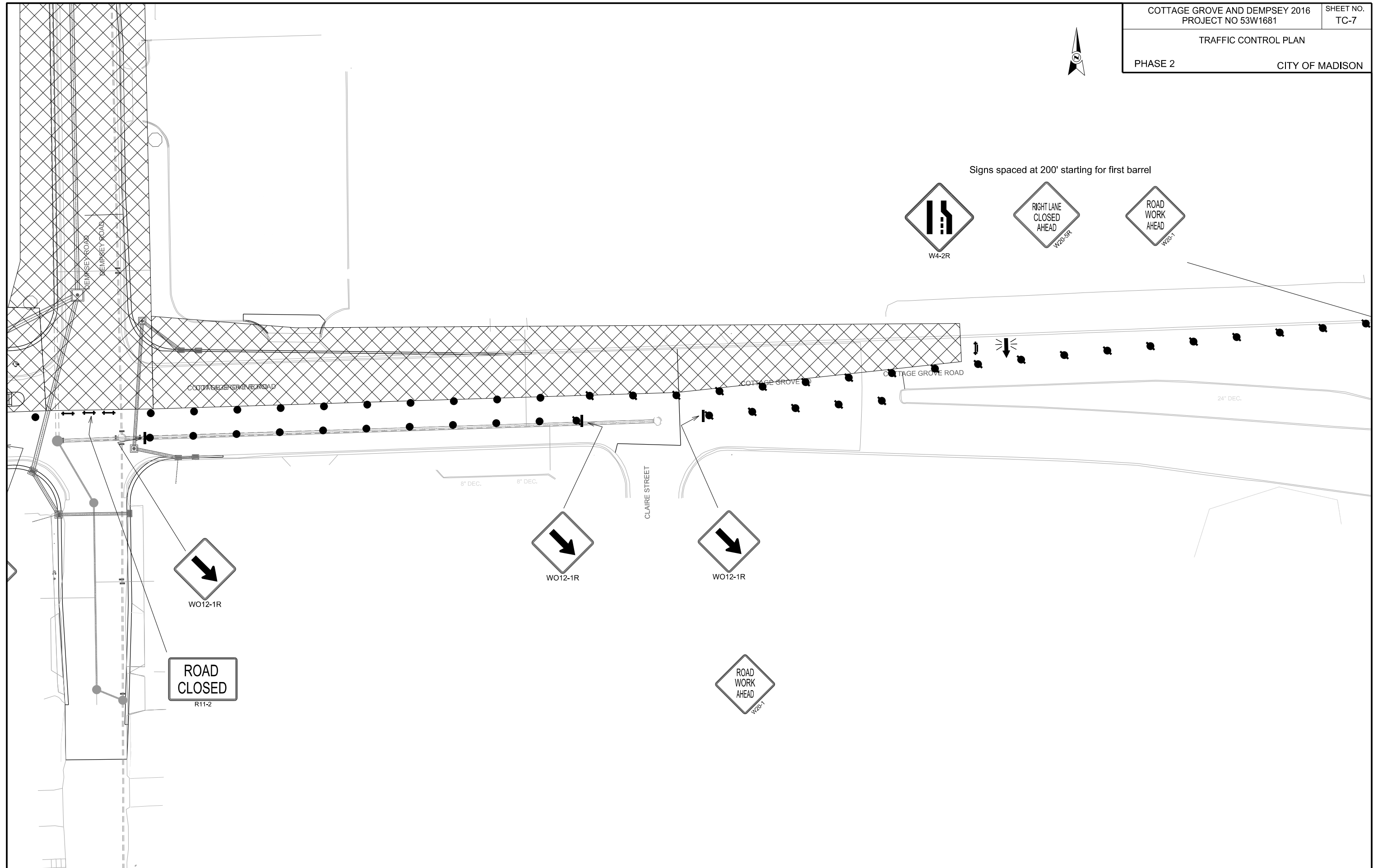



PLOT SCALE:

PLOT NAME:

REV. DATE:

ORIGINATOR: CITY OF MADISON, TRAFFIC ENG. DIV.

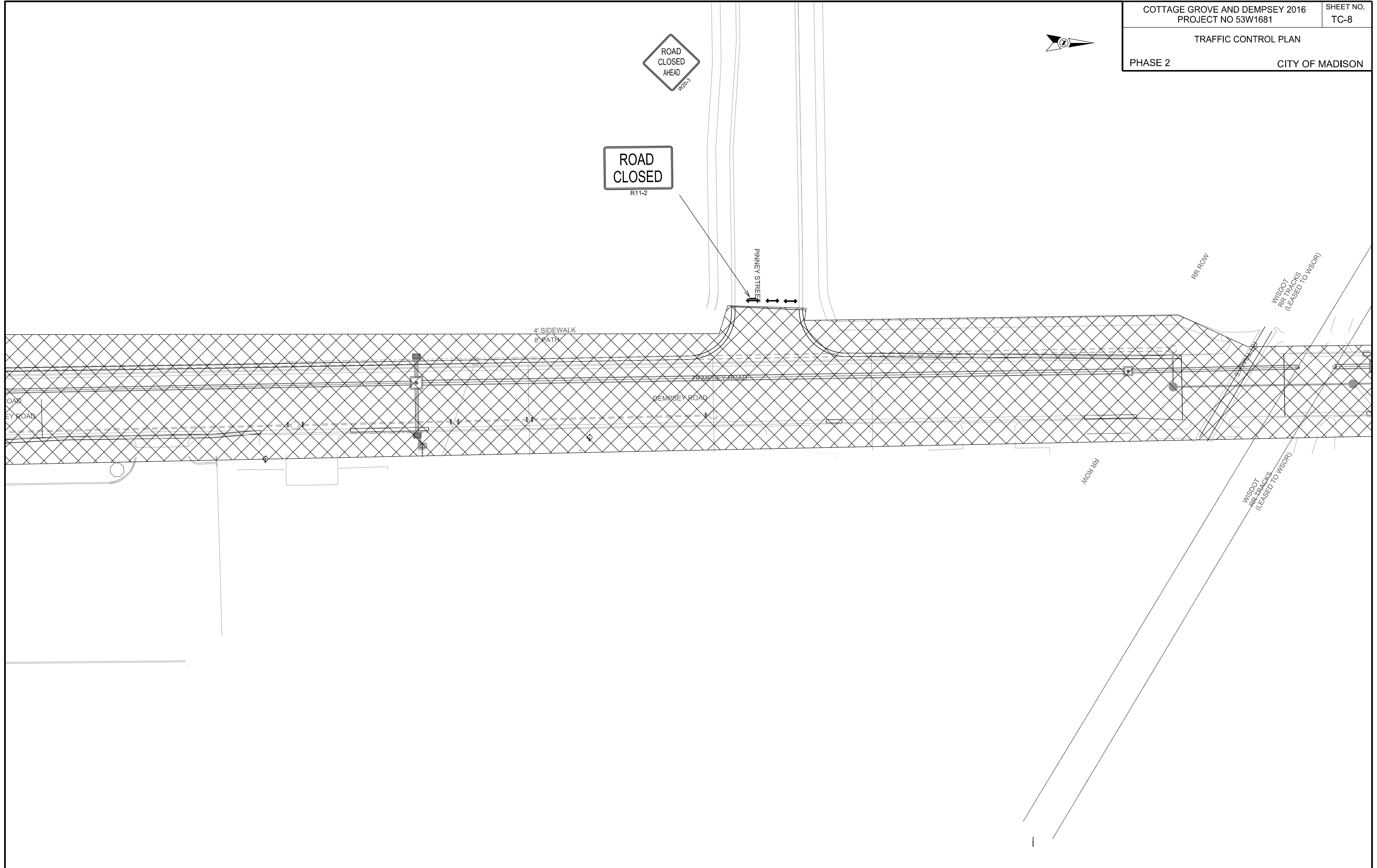



ROAD
CLOSED
R11-2

ROAD
CLOSED
R11-2

R
CL

ROAD
CLOSED
R11-2

ROAD
CLOSED
R11-2

ROAD
CLOSED
R11-2



PLOT SCALE:

PLOT NAME:

REV. DATE:

ORIGINATOR: CITY OF MADISON, TRAFFIC ENG. DIV.



PLOT SCALE:

PLOT NAME:

REV. DATE:

ORIGINATOR: CITY OF MADISON, TRAFFIC ENG. DIV.

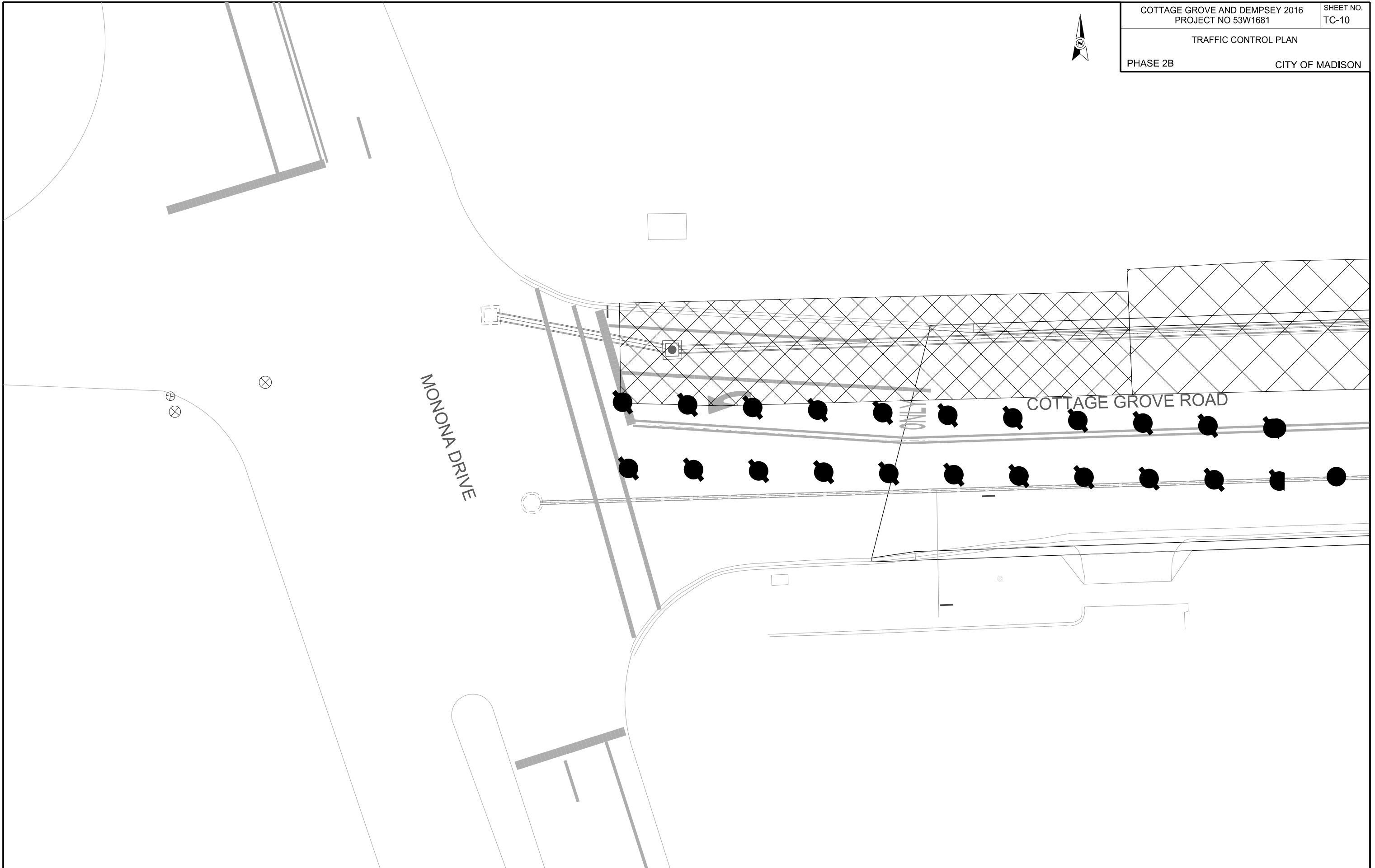



PLOT SCALE:

PLOT NAME:

REV. DATE:

ORIGINATOR: CITY OF MADISON, TRAFFIC ENG. DIV.

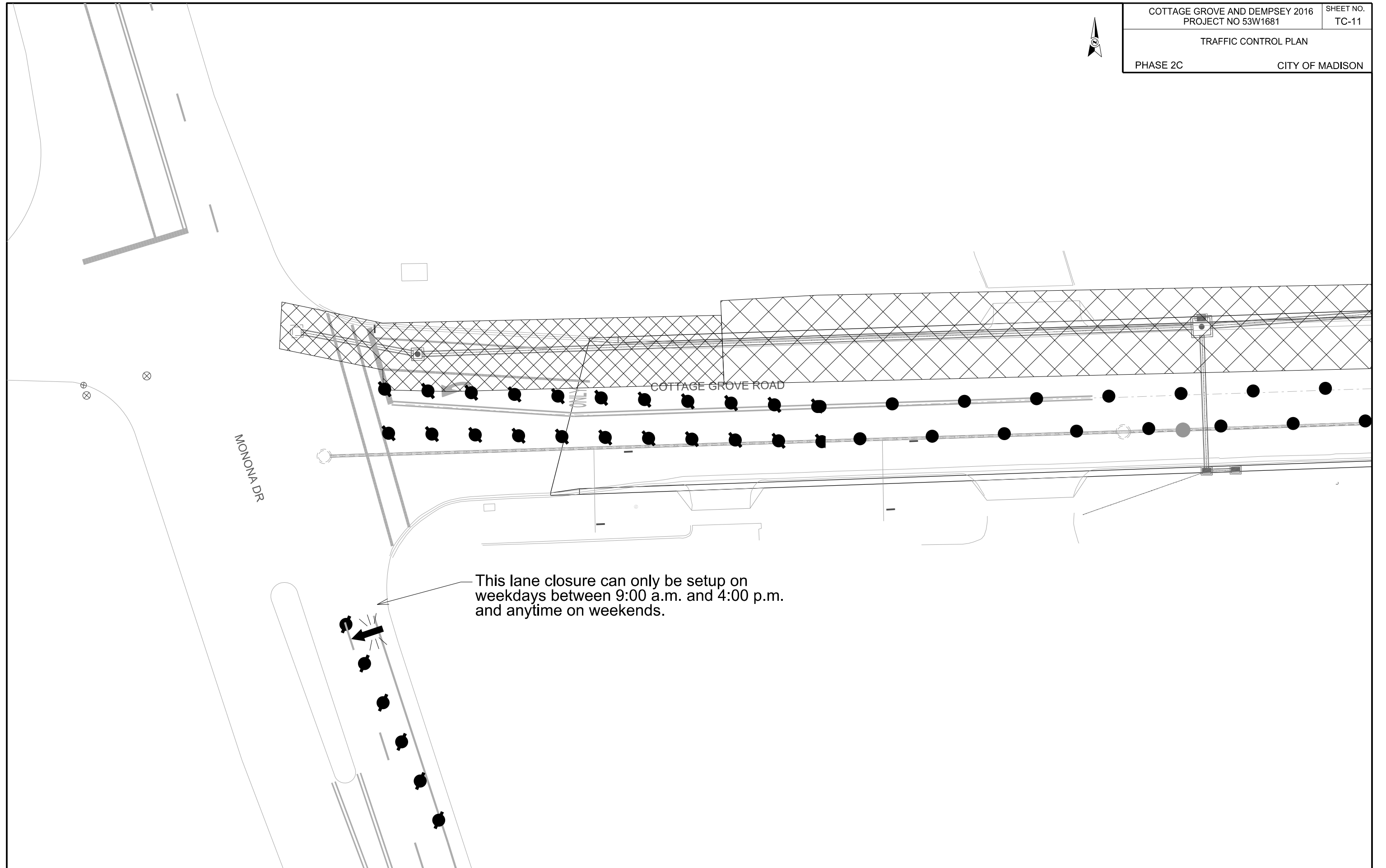



PLOT SCALE:
PLOT NAME:
REV. DATE:
ORIGINATOR: CITY OF MADISON, TRAFFIC ENG. DIV.

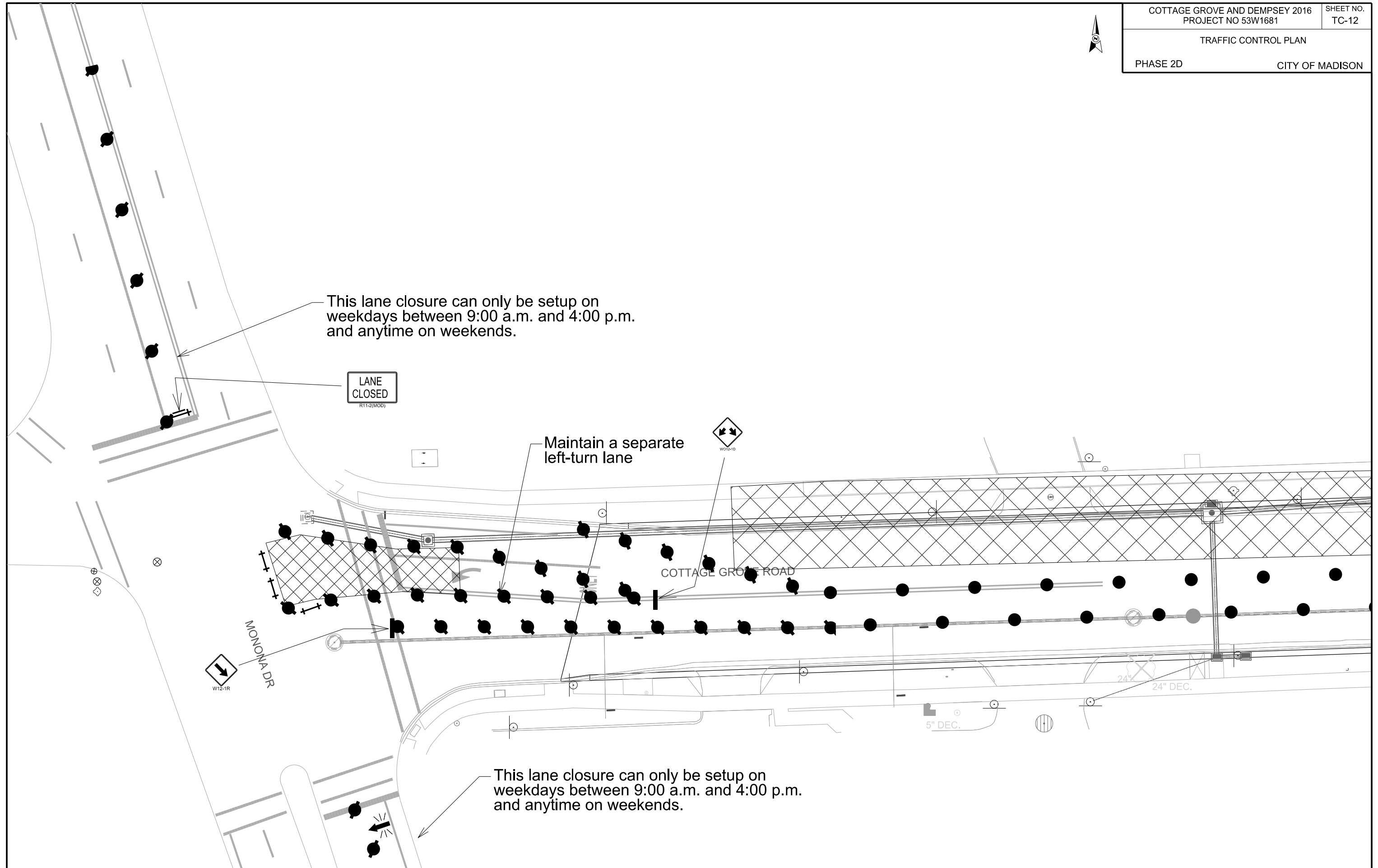



PLOT SCALE:

PLOT NAME:

REV. DATE:

ORIGINATOR: CITY OF MADISON, TRAFFIC ENG. DIV.

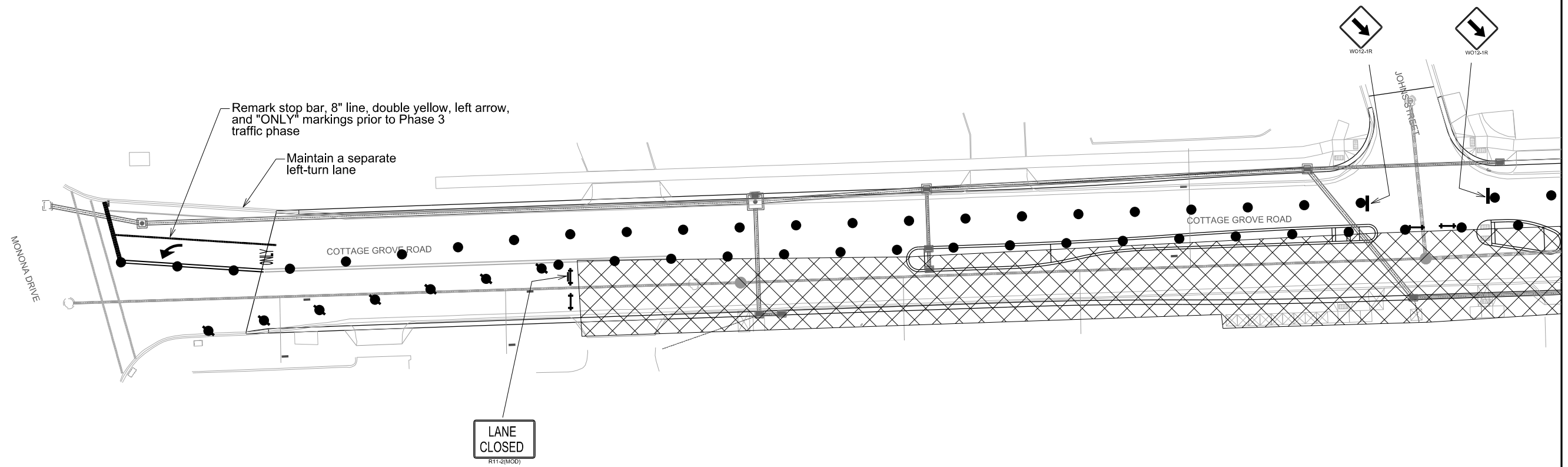



PLOT SCALE:

PLOT NAME:

REV. DATE:

ORIGINATOR: CITY OF MADISON, TRAFFIC ENG. DIV.

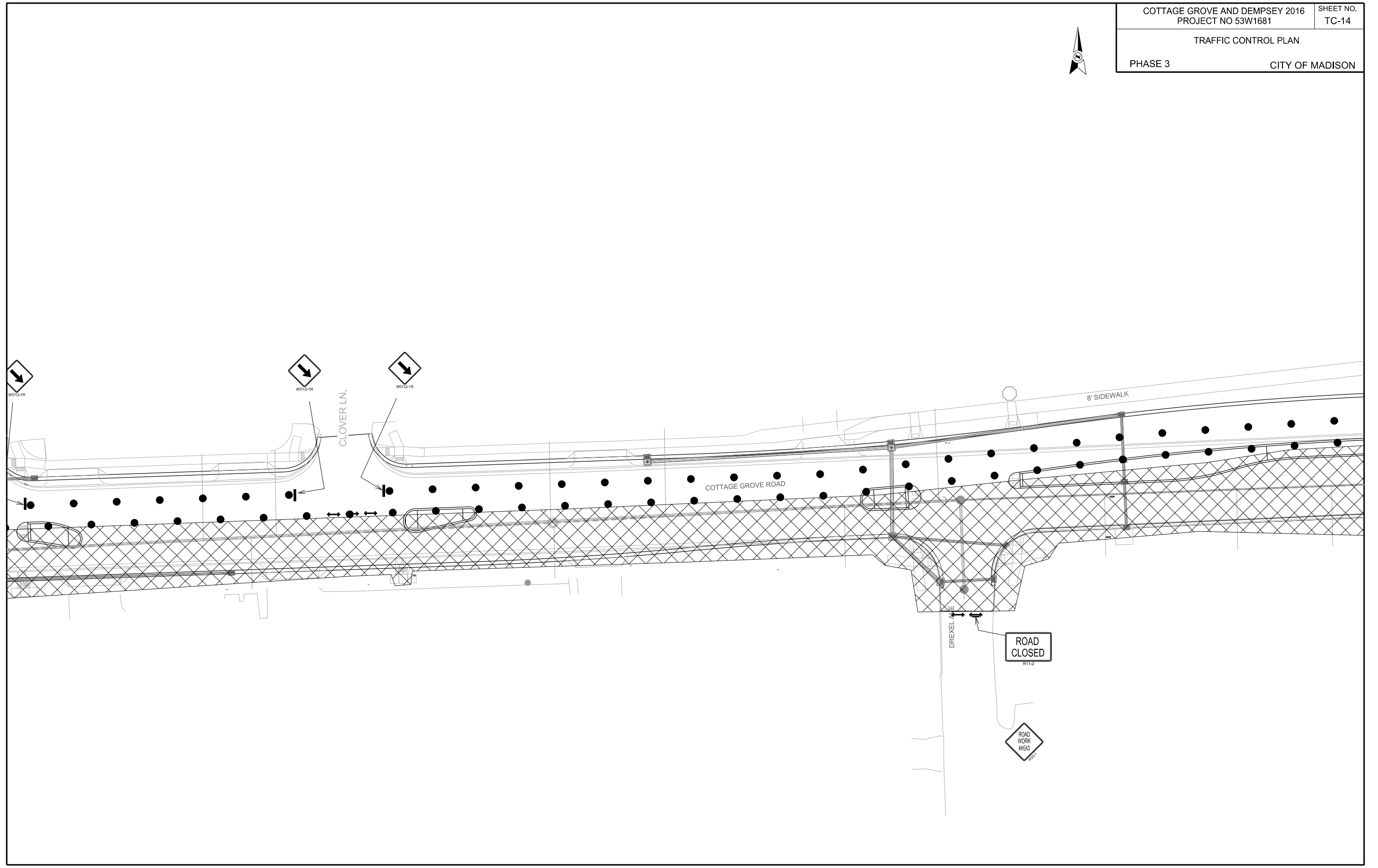

TRAFFIC CONTROL PLAN

PHASE 3

CITY OF MADISON



PLOT SCALE:

PLOT NAME:

REV. DATE:

ORIGINATOR: CITY OF MADISON, TRAFFIC ENG. DIV.

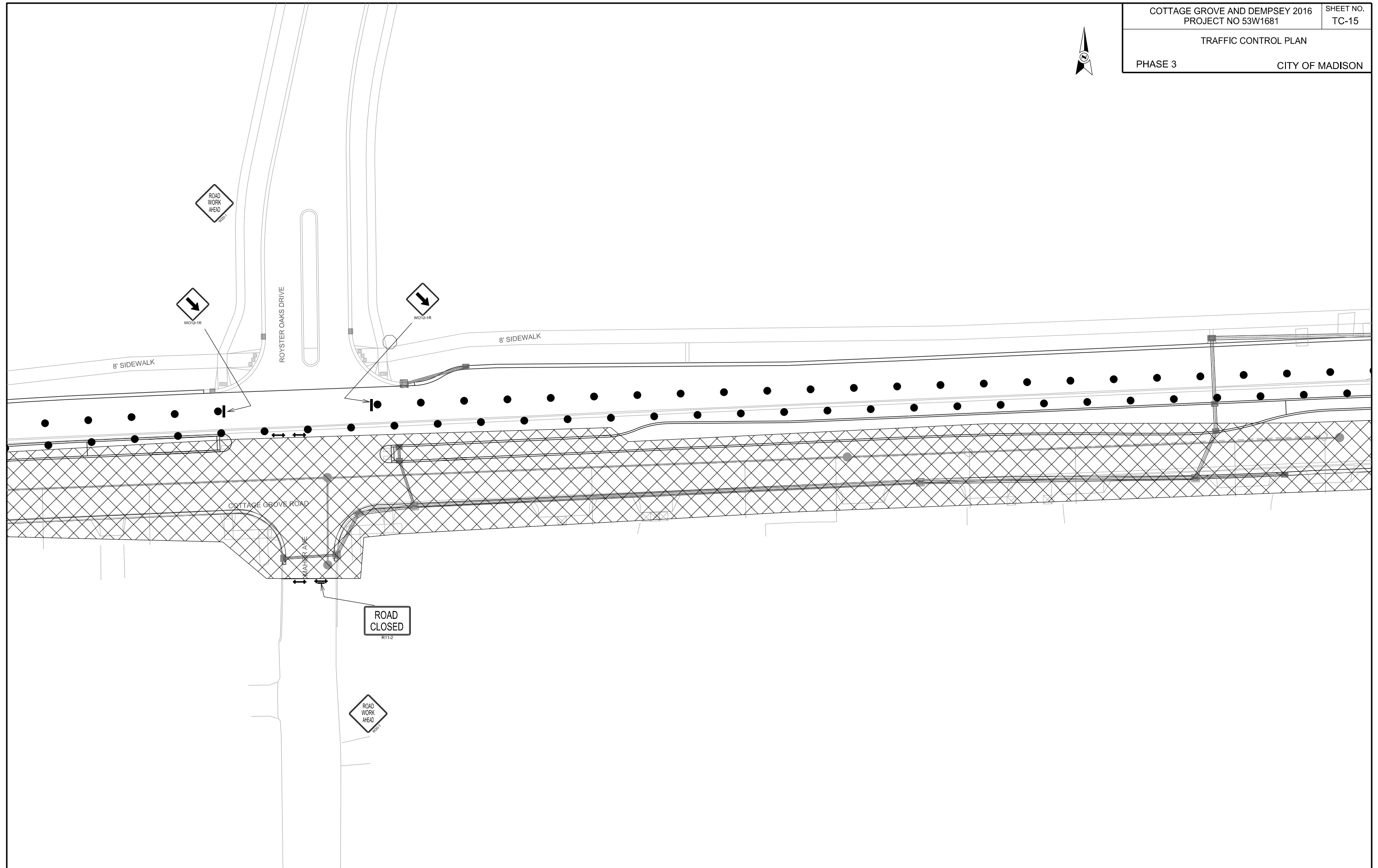



PLOT SCALE:

PLOT NAME:

REV. DATE:

ORIGINATOR: CITY OF MADISON, TRAFFIC ENG. DIV.

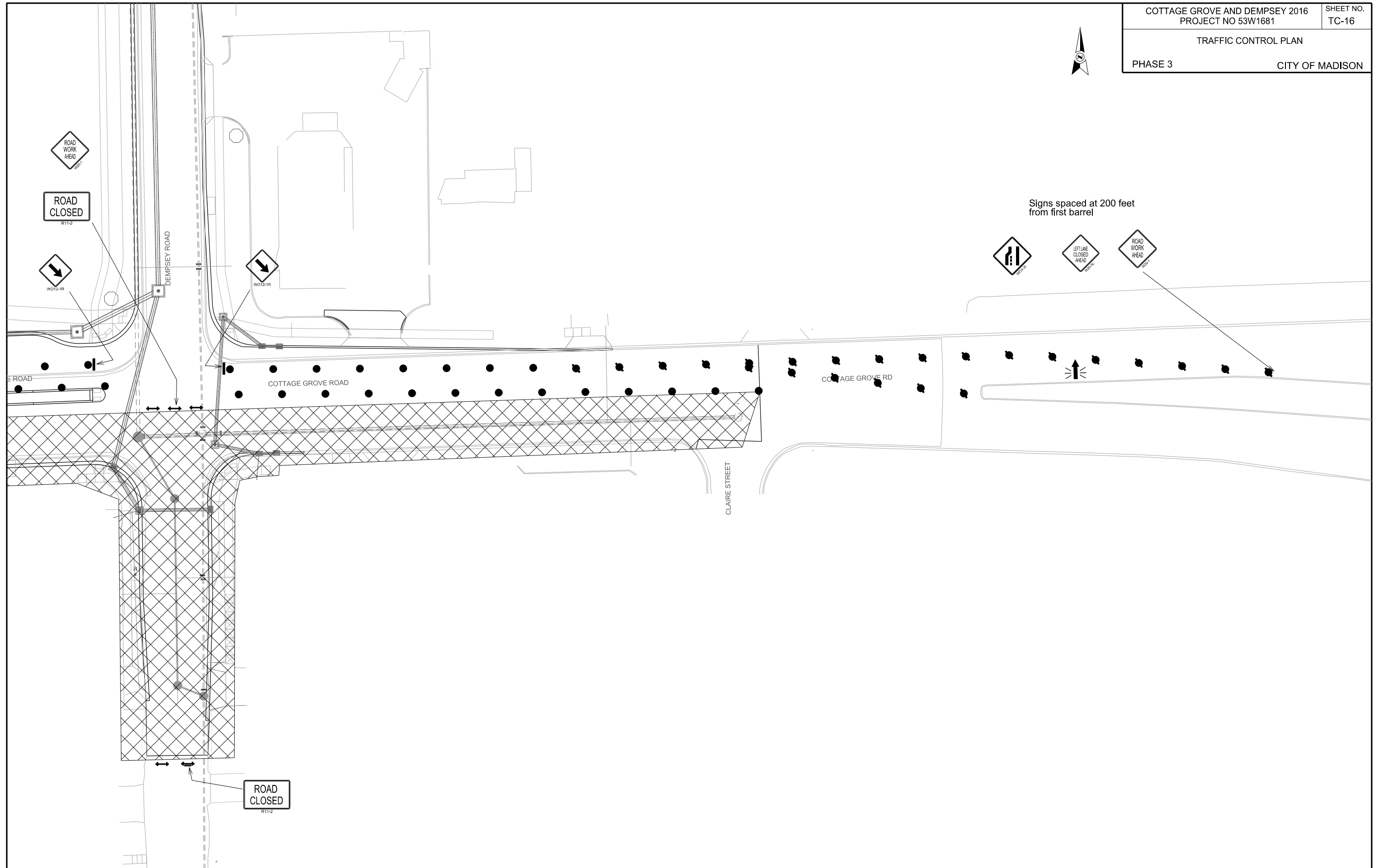

Signs spaced at 200 feet
from first barrel





PLOT SCALE:

PLOT NAME:

REV. DATE:

ORIGINATOR: CITY OF MADISON, TRAFFIC ENG. DIV.

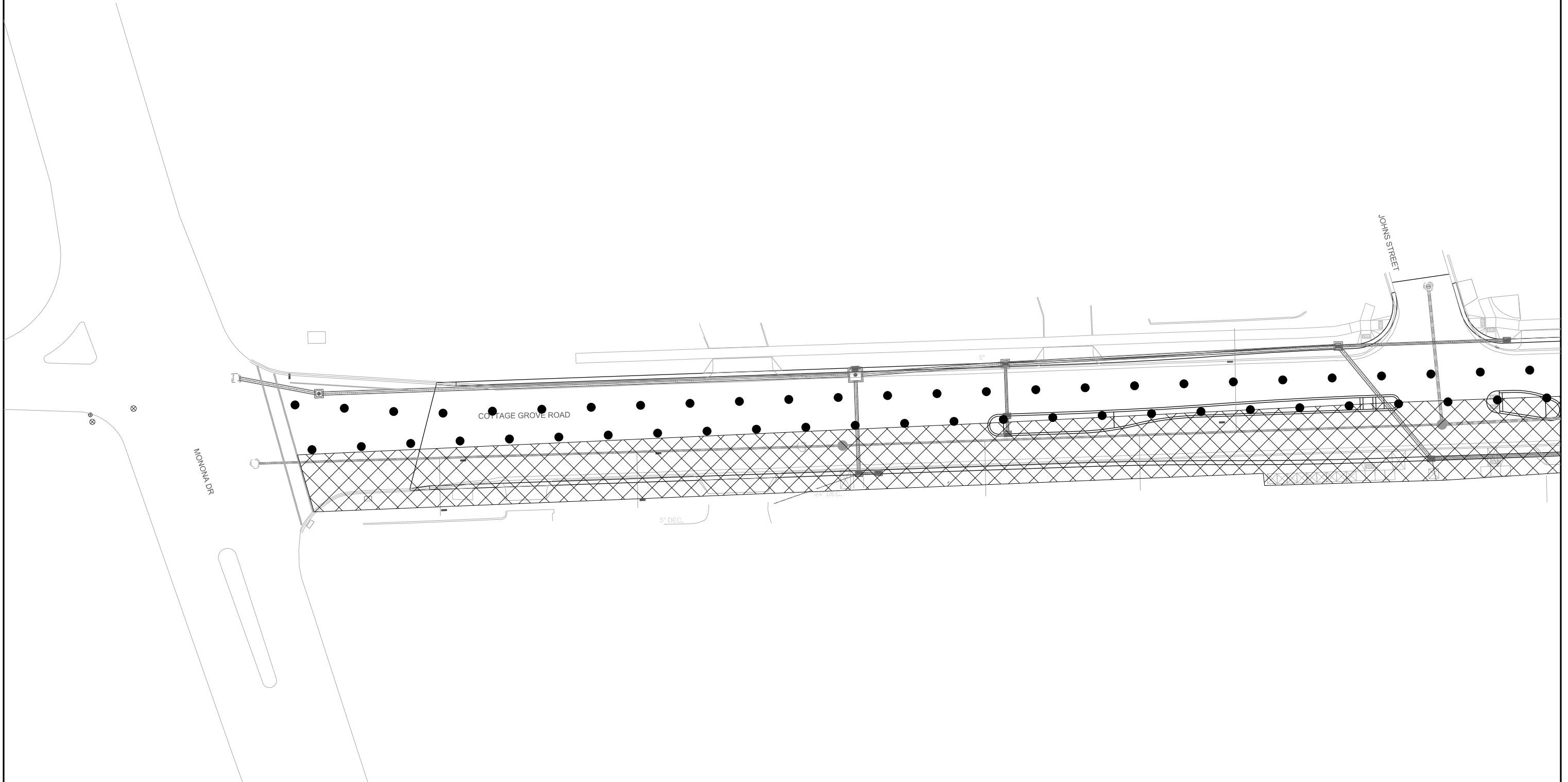



PLOT SCALE:

PLOT NAME:

REV. DATE:

ORIGINATOR: CITY OF MADISON, TRAFFIC ENG. DIV.

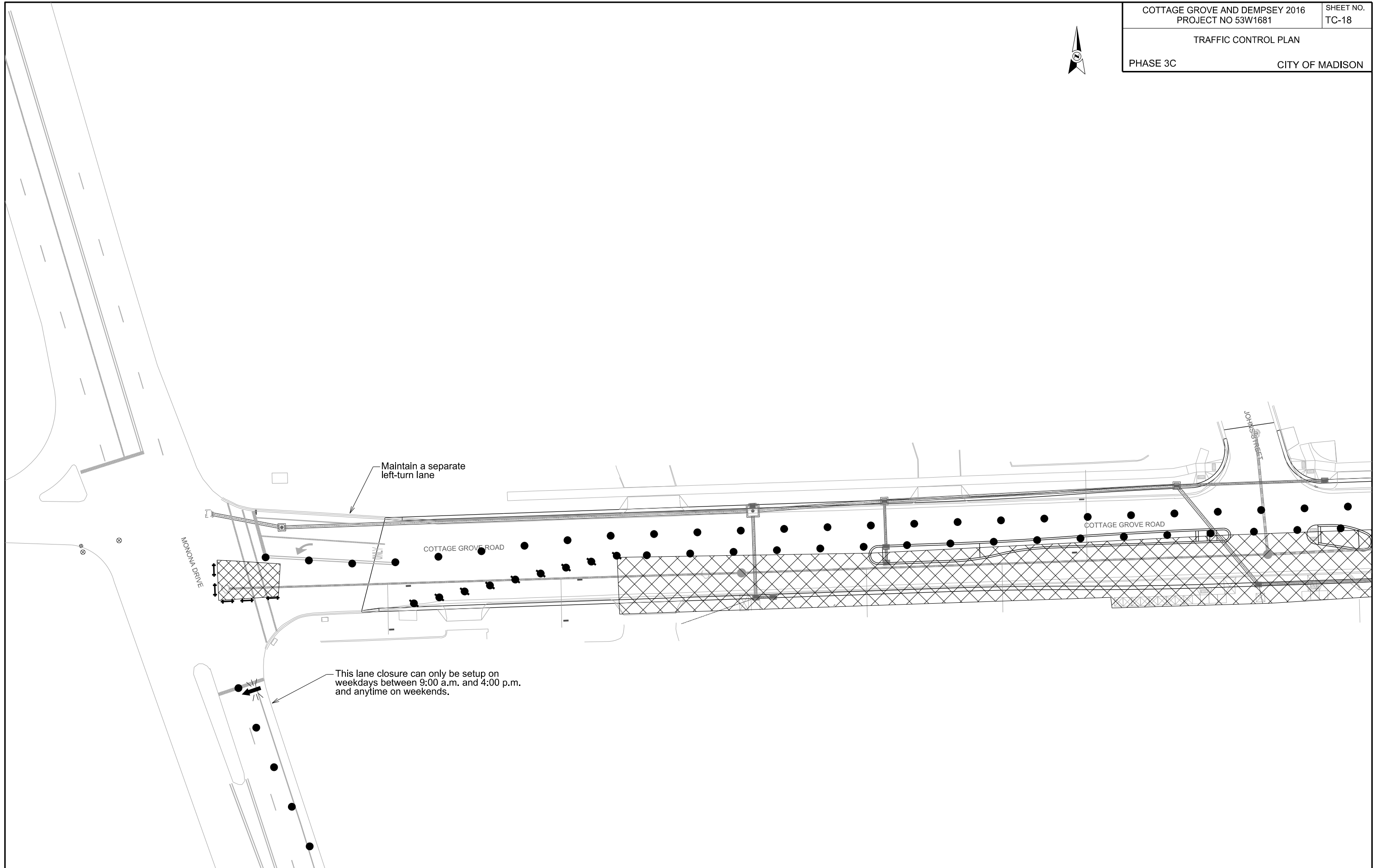

CROSS SECTIONS
COTTAGE GROVE ROAD CITY OF MADISON

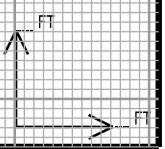
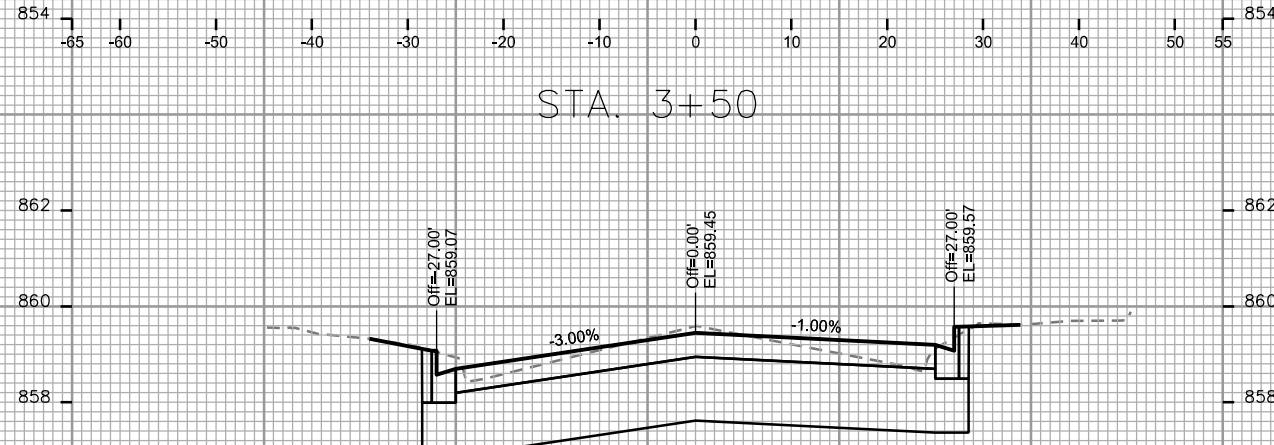
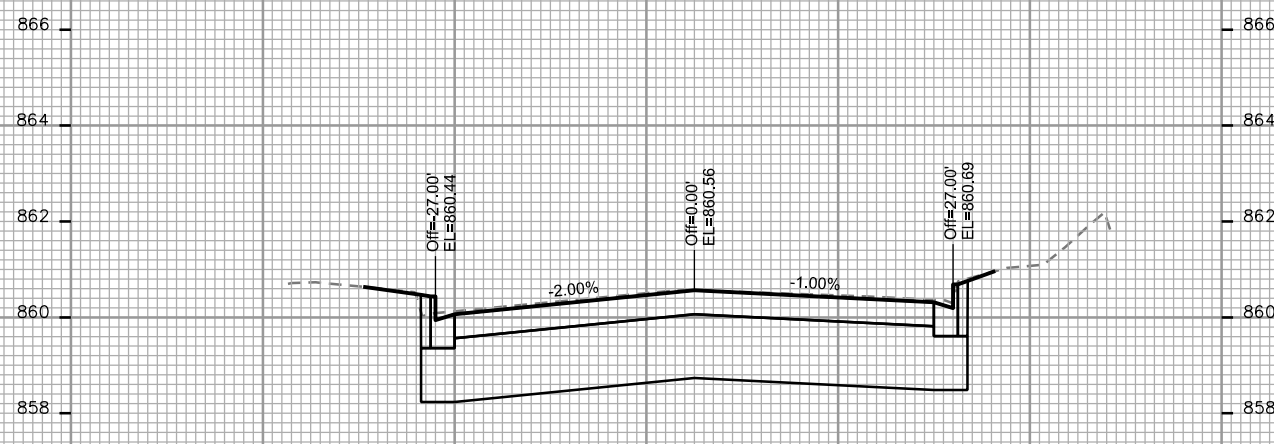
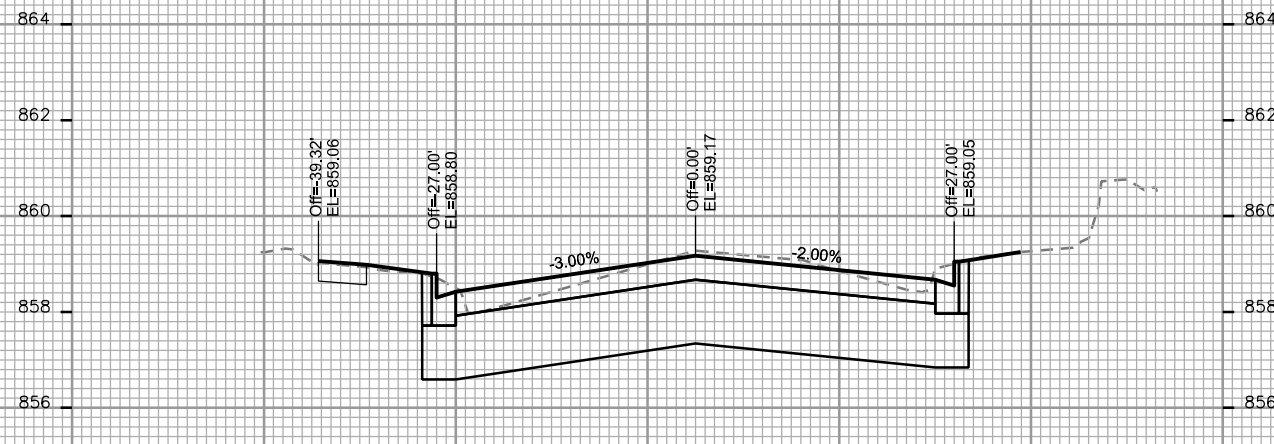
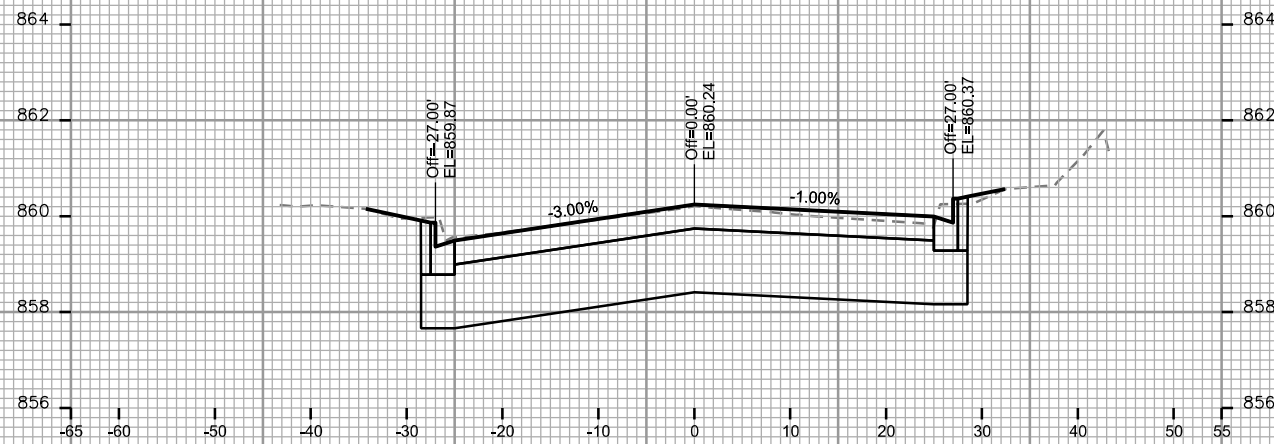
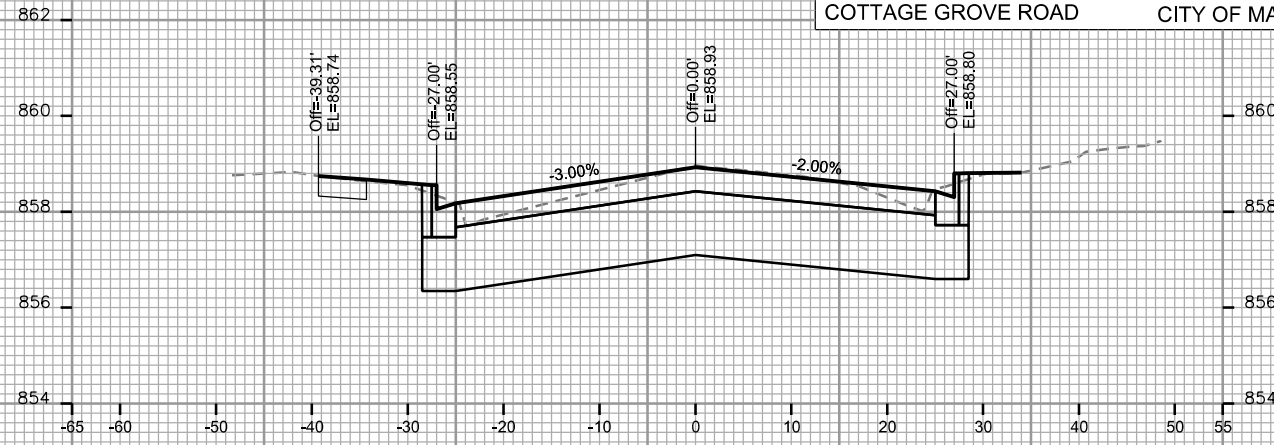
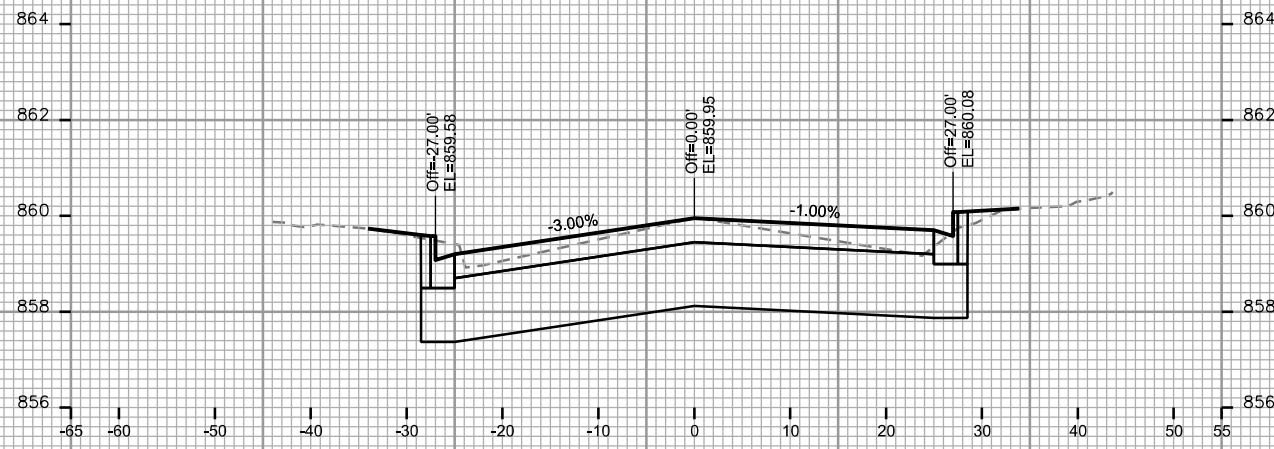

PLOT SCALE: _____

PLOT NAME: _____

REV. DATE: _____

ORIGINATOR: CITY OF MADISON - STREETS DIVISION

PLOT SCALE: _____

PLOT NAME: _____

REV. DATE: _____

ORIGINATOR: CITY OF MADISON, STREETS DIVISION

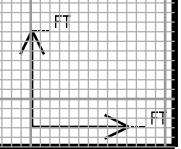
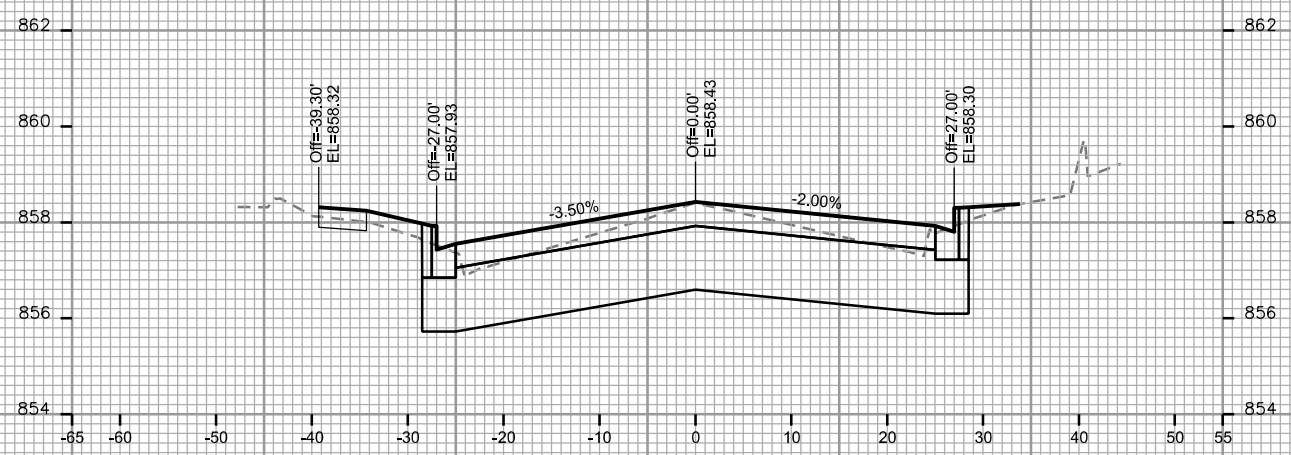
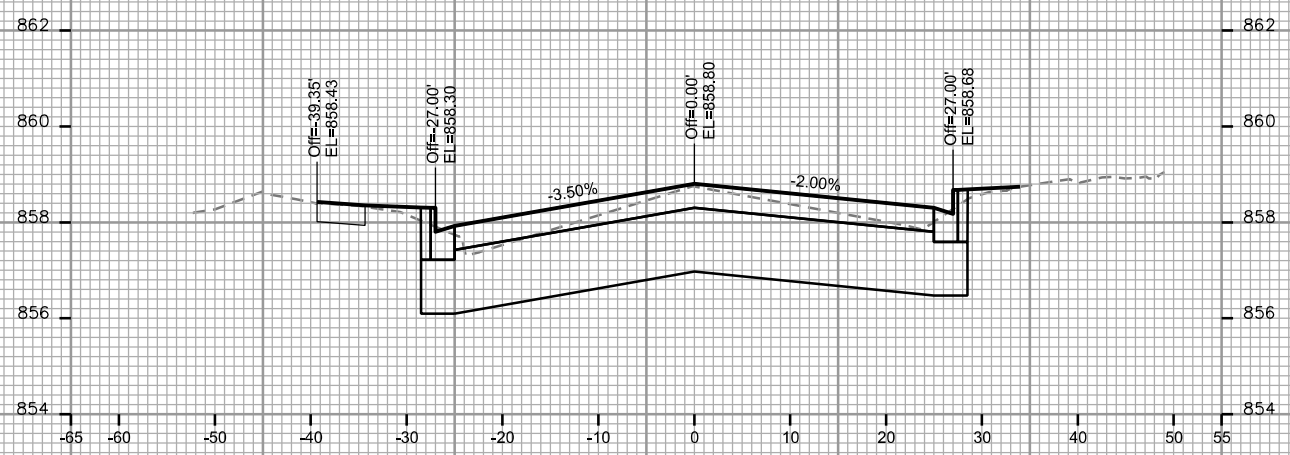
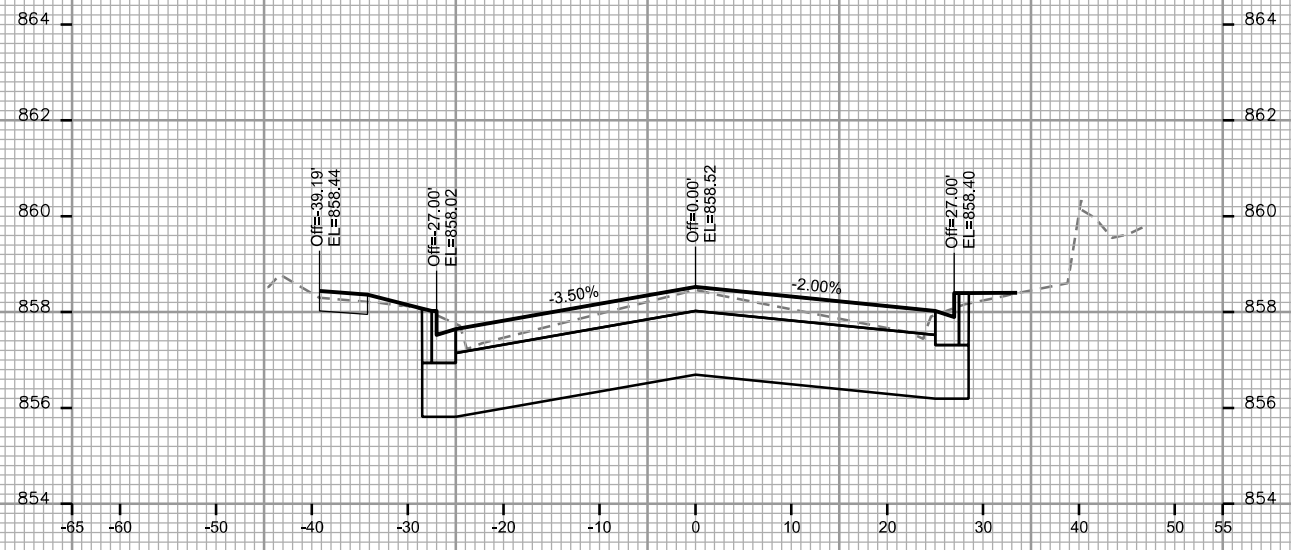
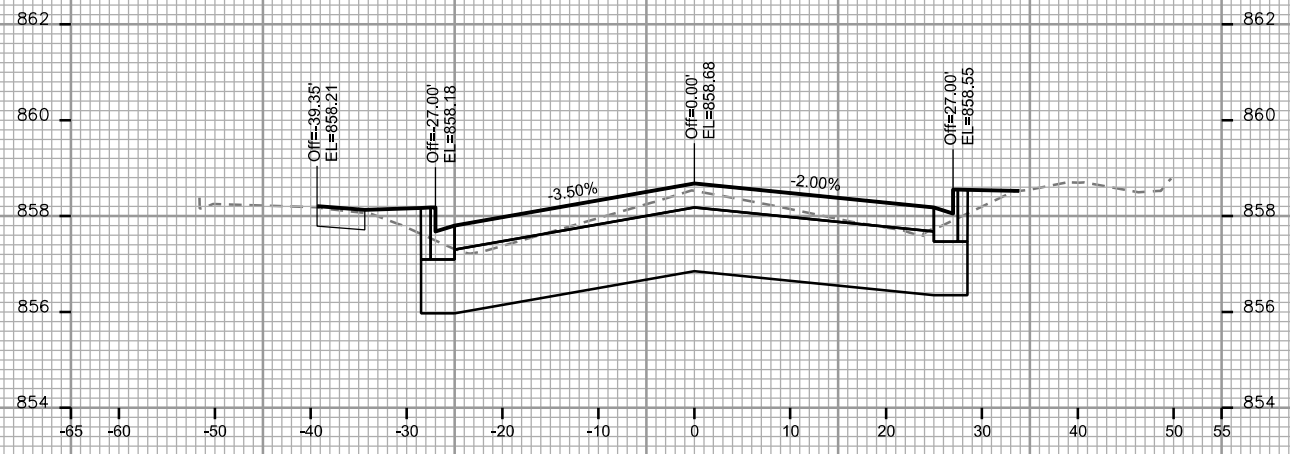
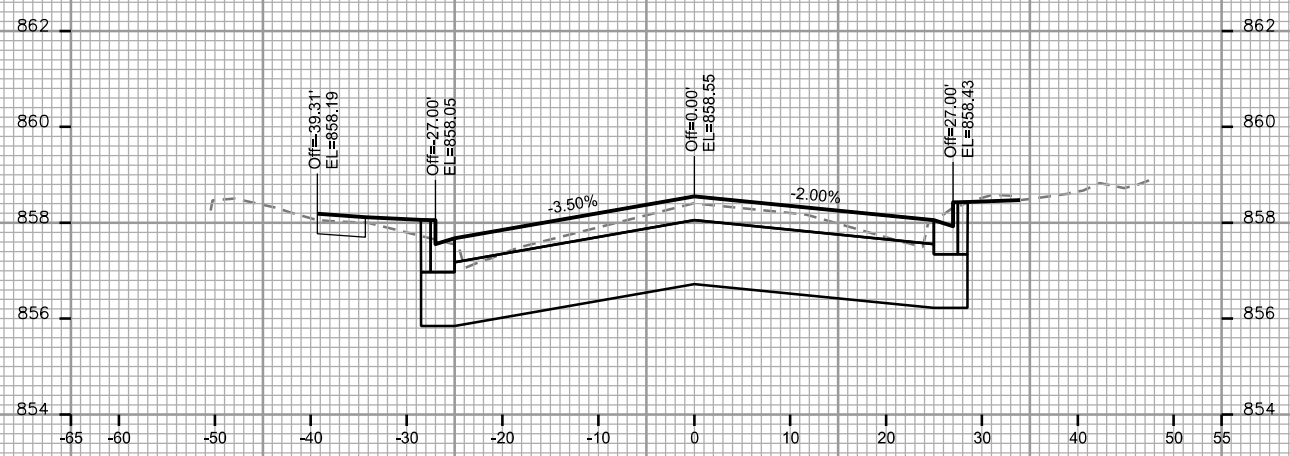

PLOT SCALE: _____

PLOT NAME: _____

REV. DATE: _____

ORIGINATOR: CITY OF MADISON - STREETS DIVISION

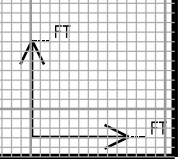
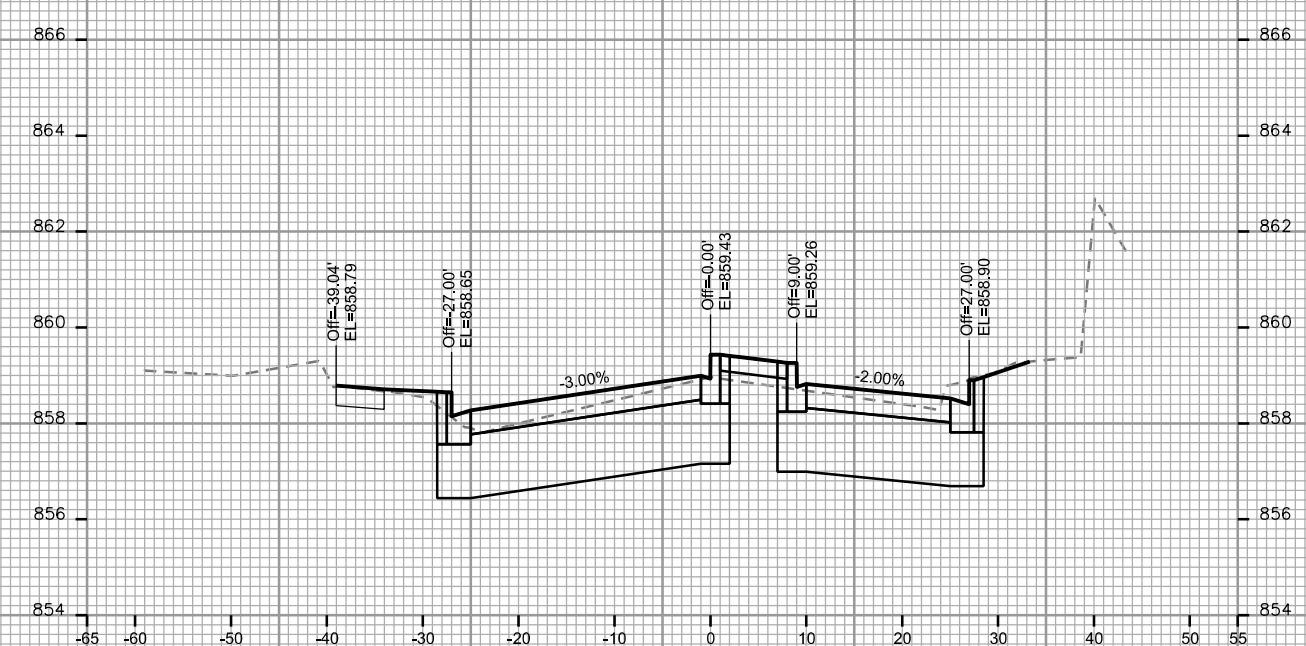
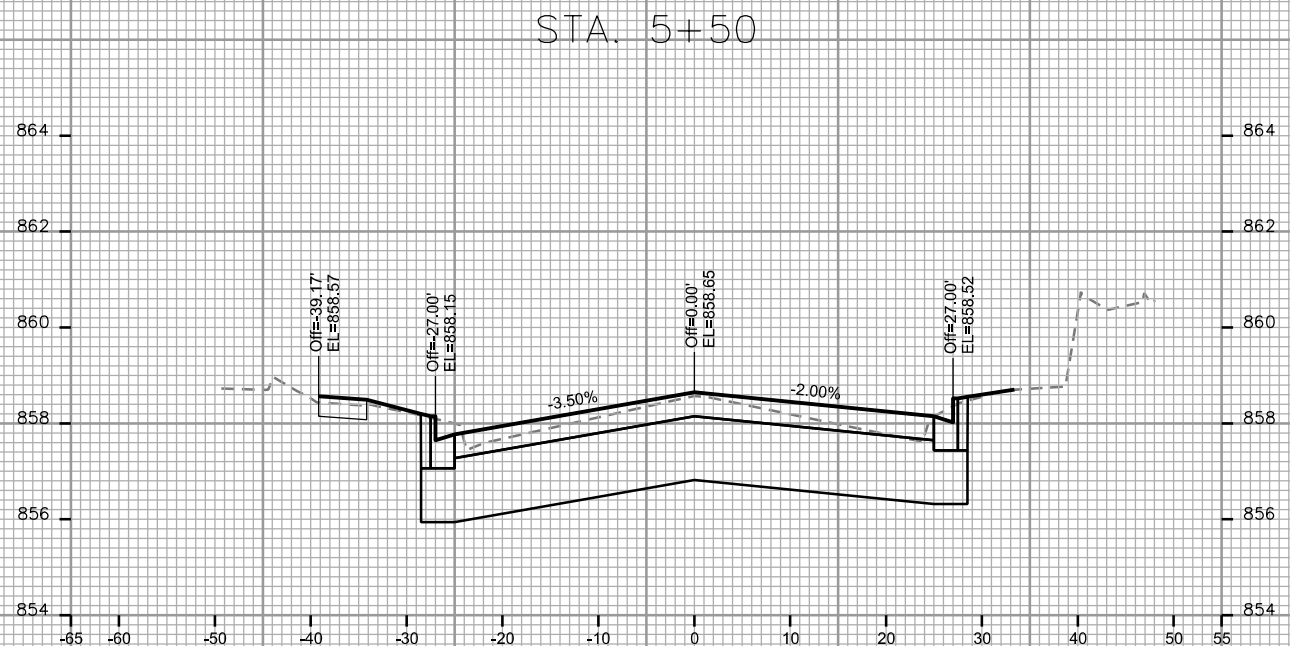
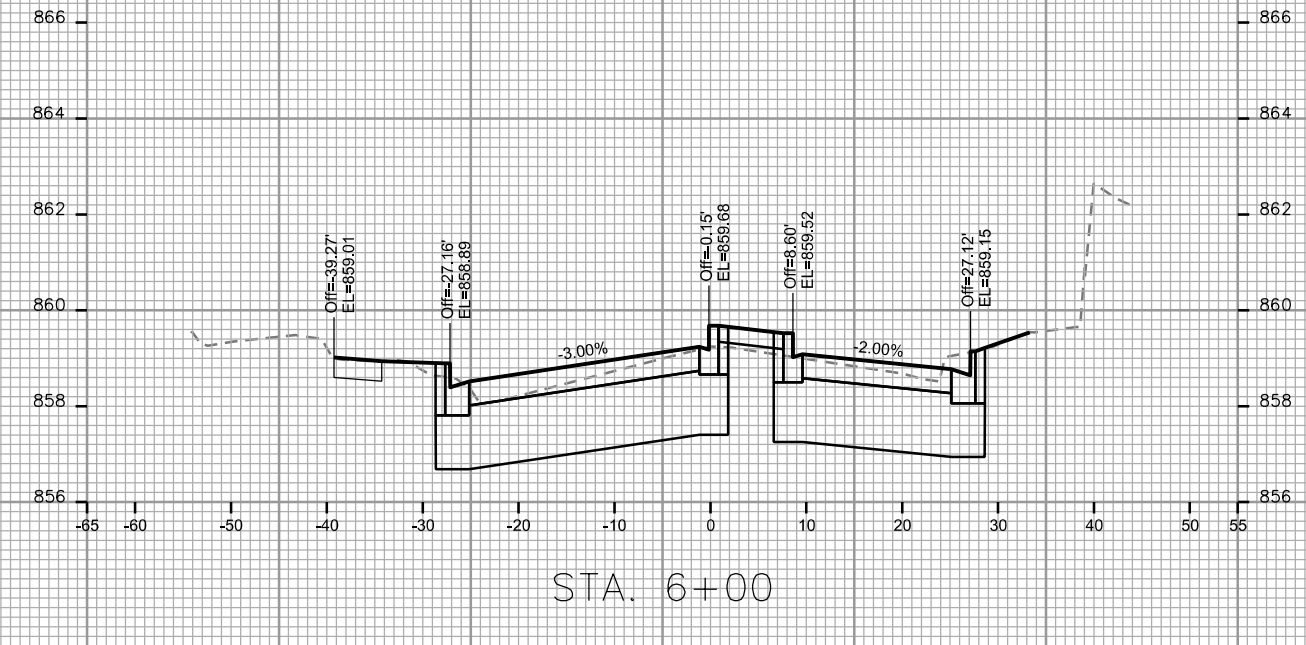
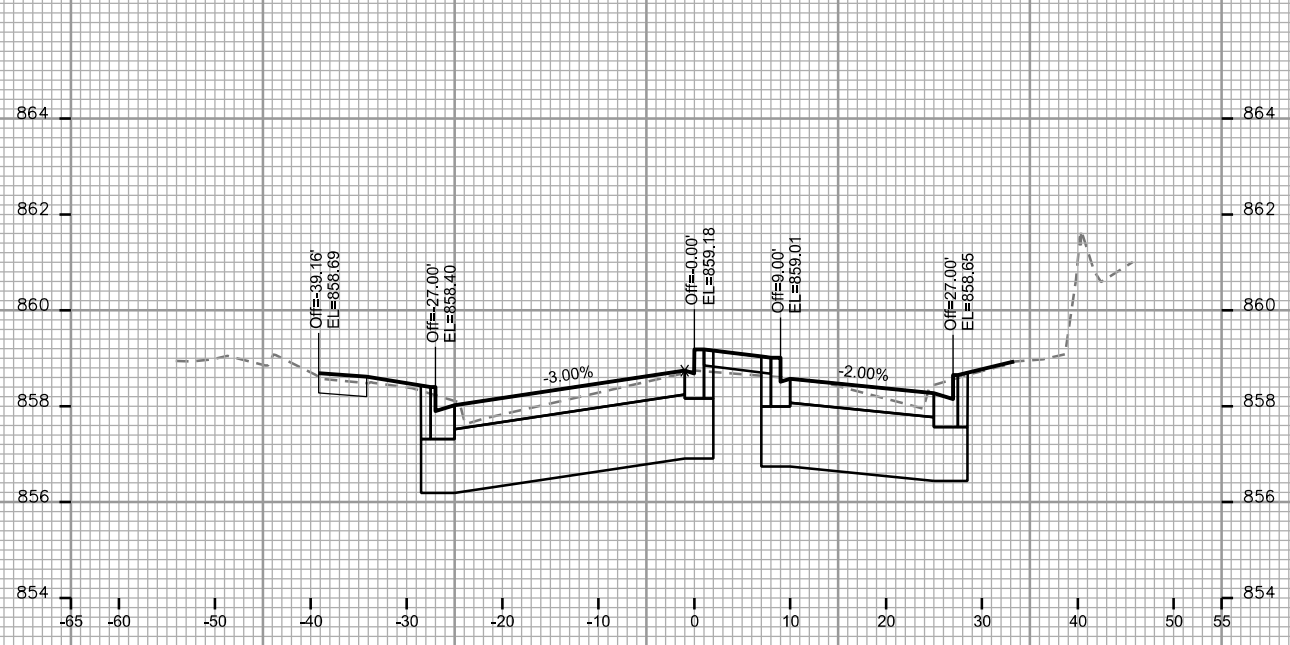

PLOT SCALE: _____

PLOT NAME: _____

REV. DATE: _____

ORIGINATOR: CITY OF MADISON - STREETS DIVISION

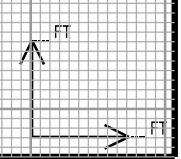
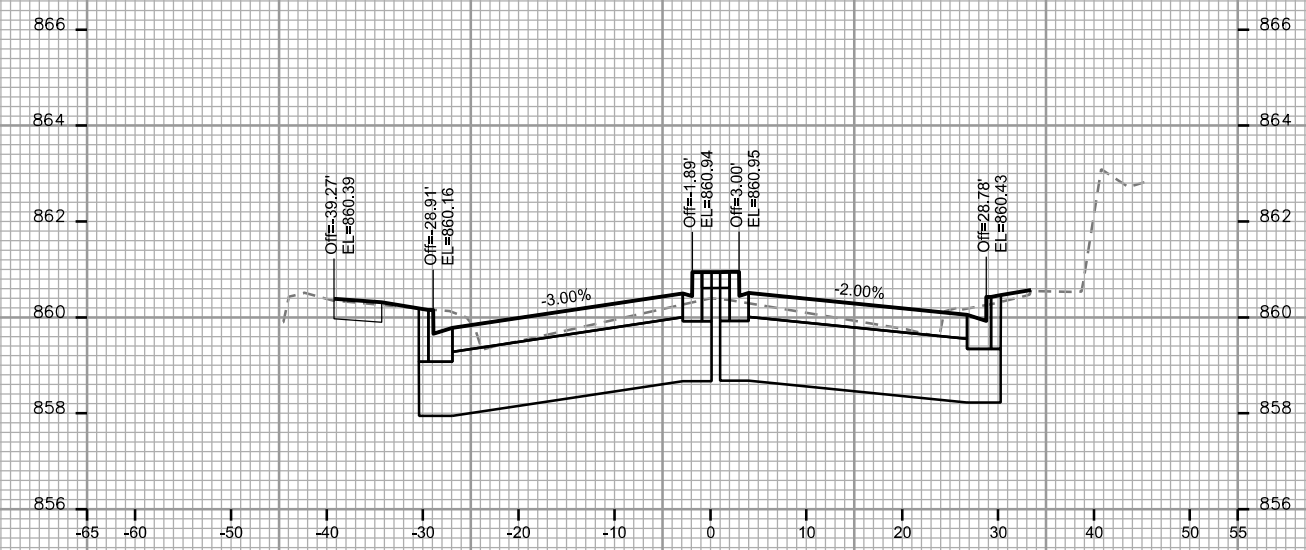
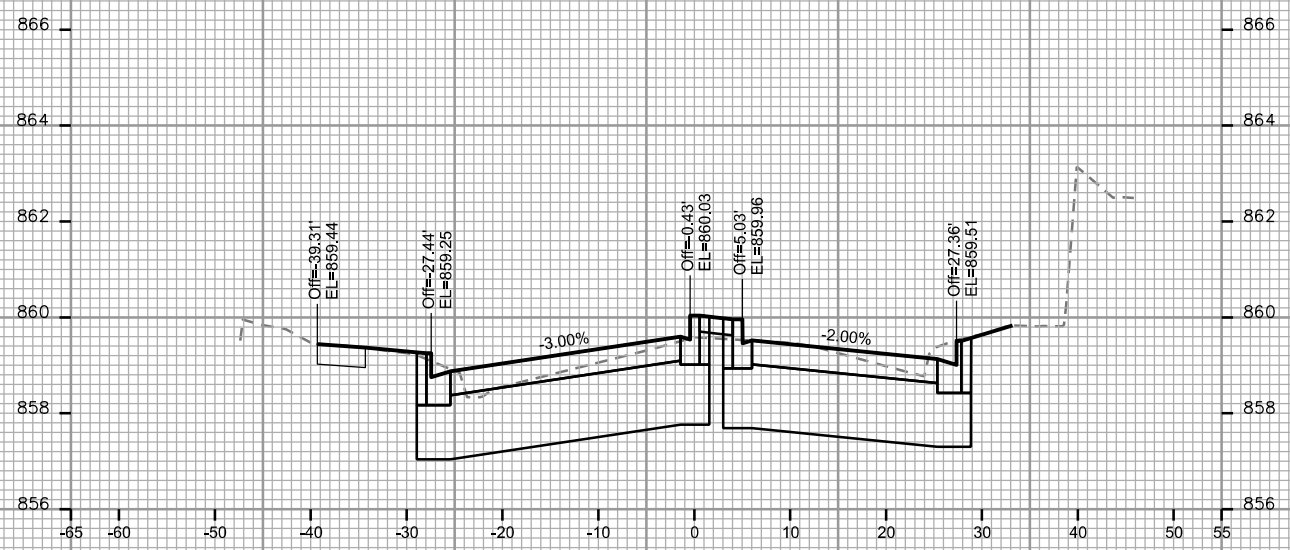
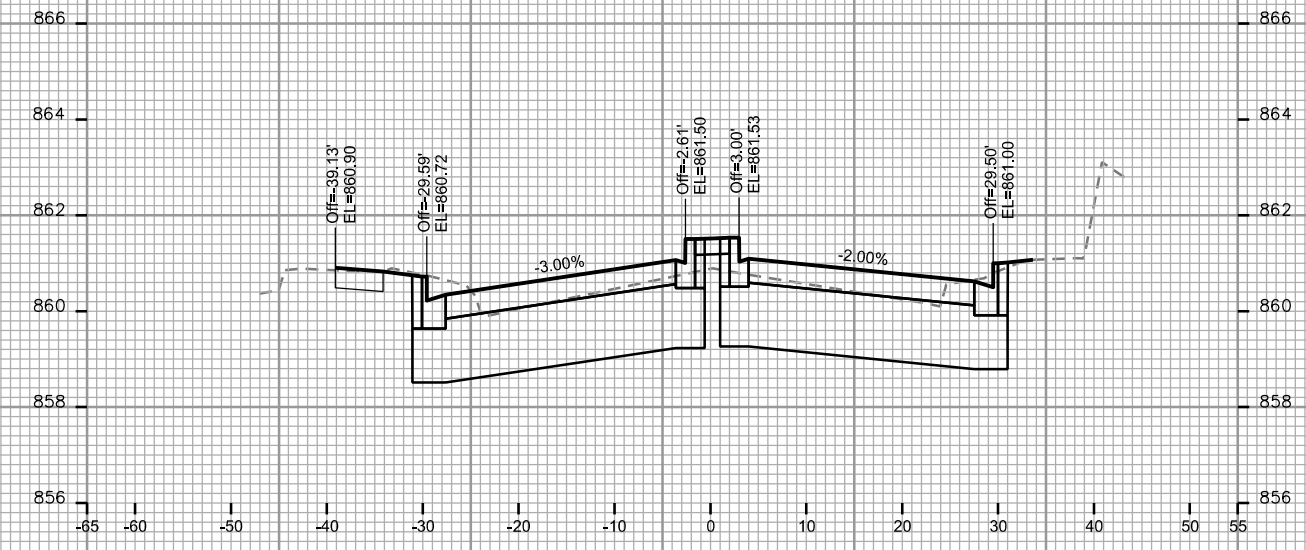
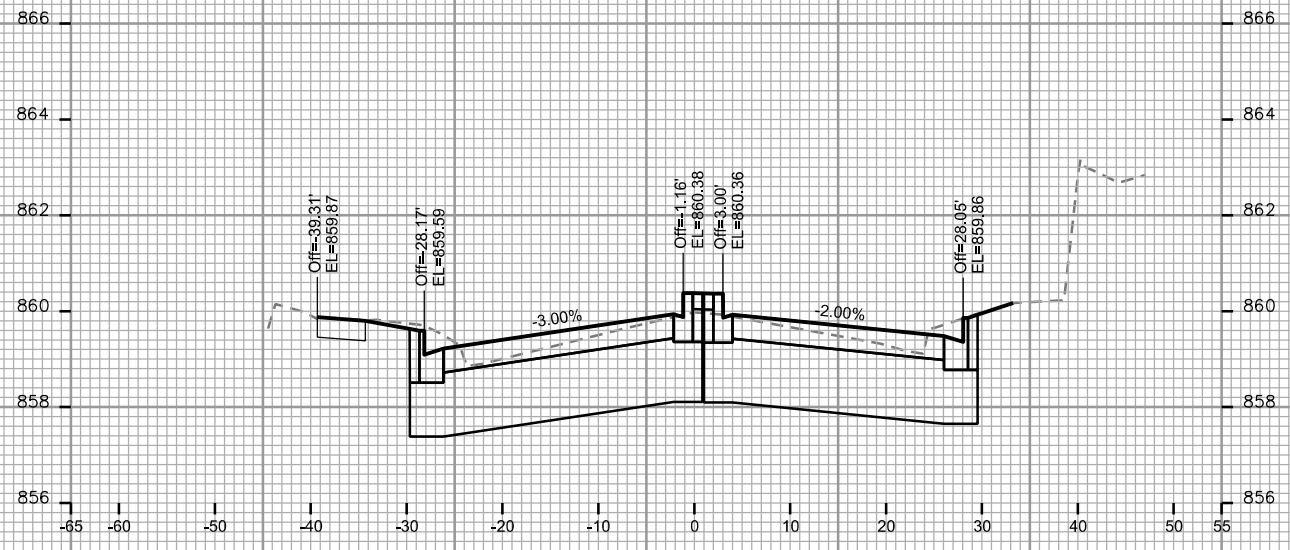

CROSS SECTIONS
COTTAGE GROVE ROAD CITY OF MADISON

PLOT SCALE: _____

PLOT NAME: _____

REV. DATE: _____

ORIGINATOR: CITY OF MADISON, STREETS DIVISION

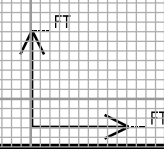
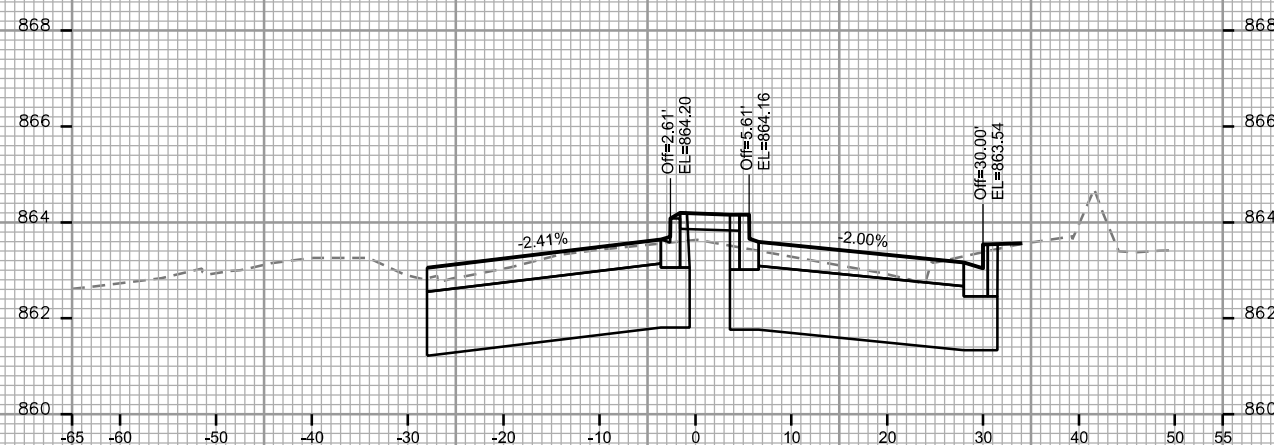
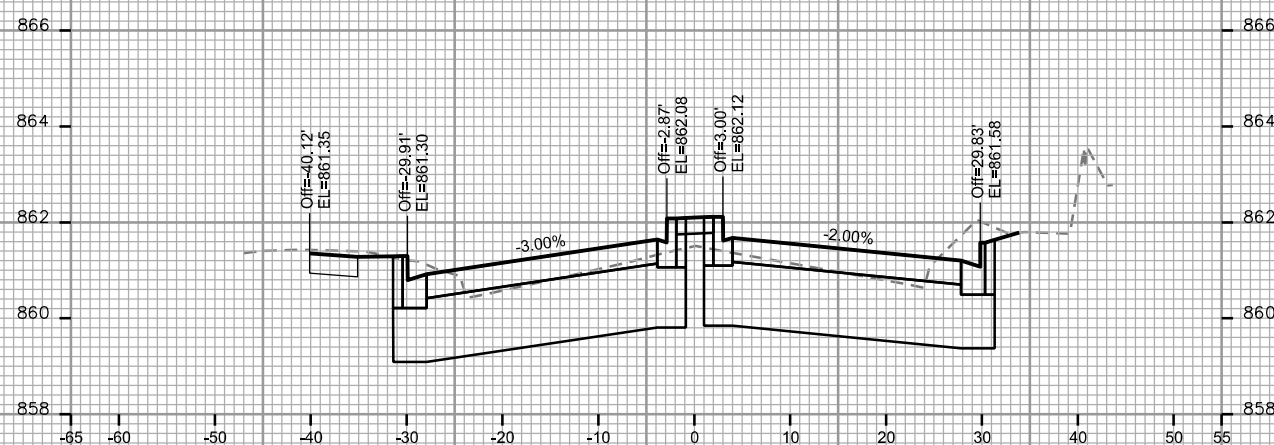
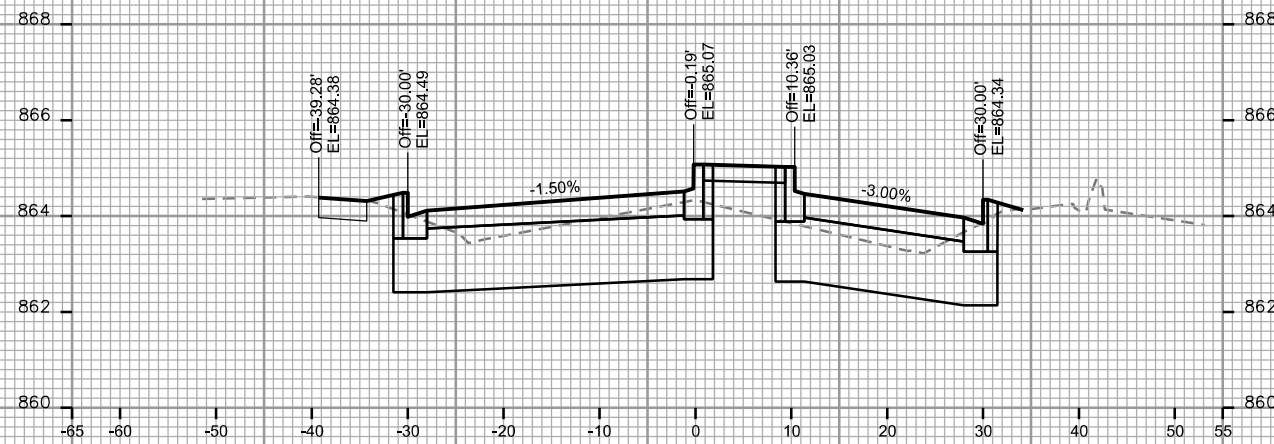
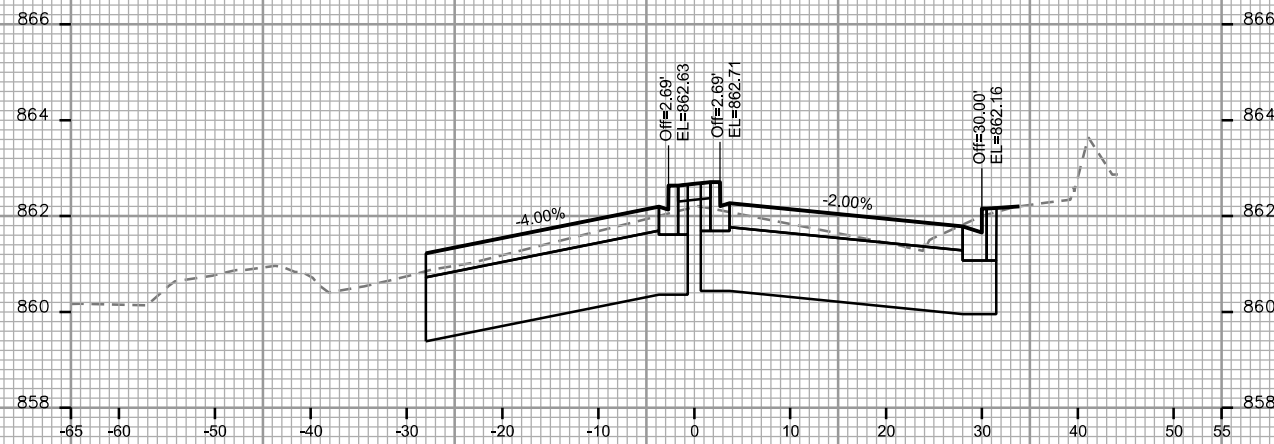
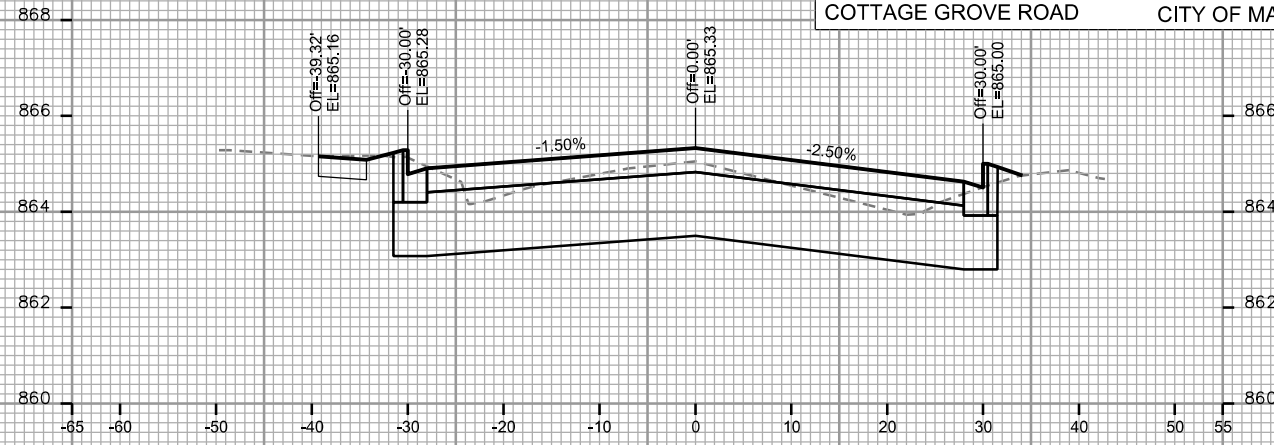
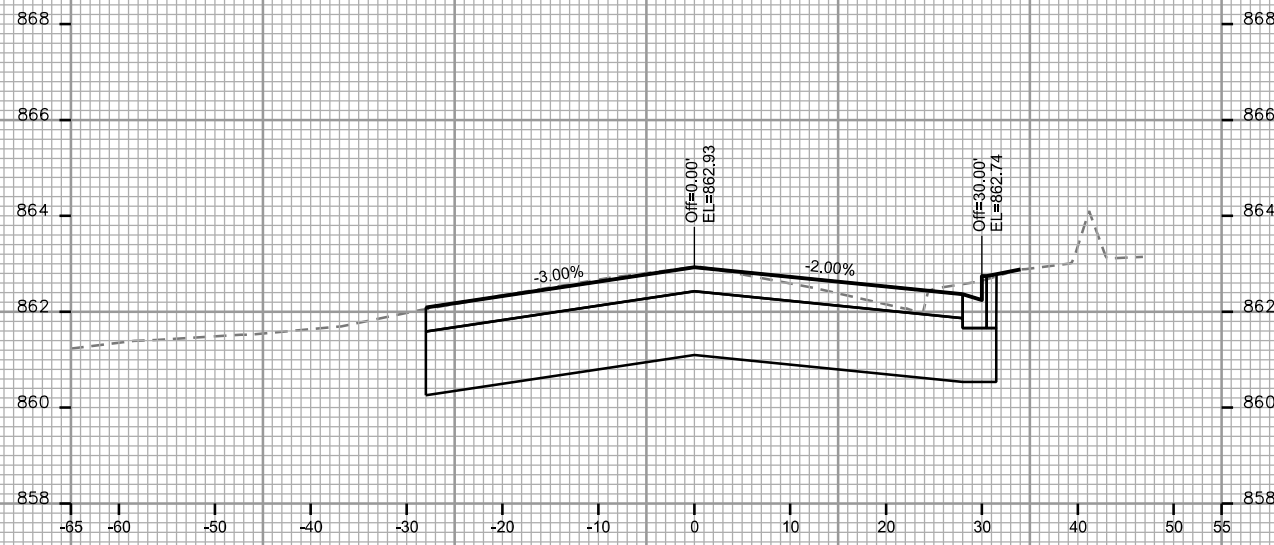

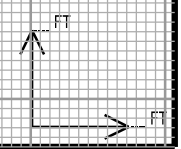
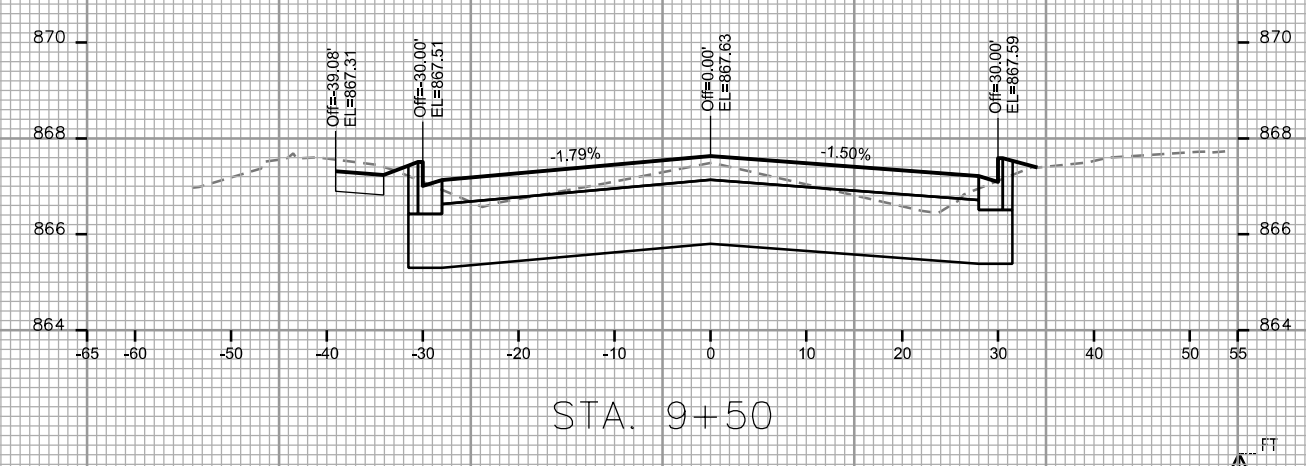
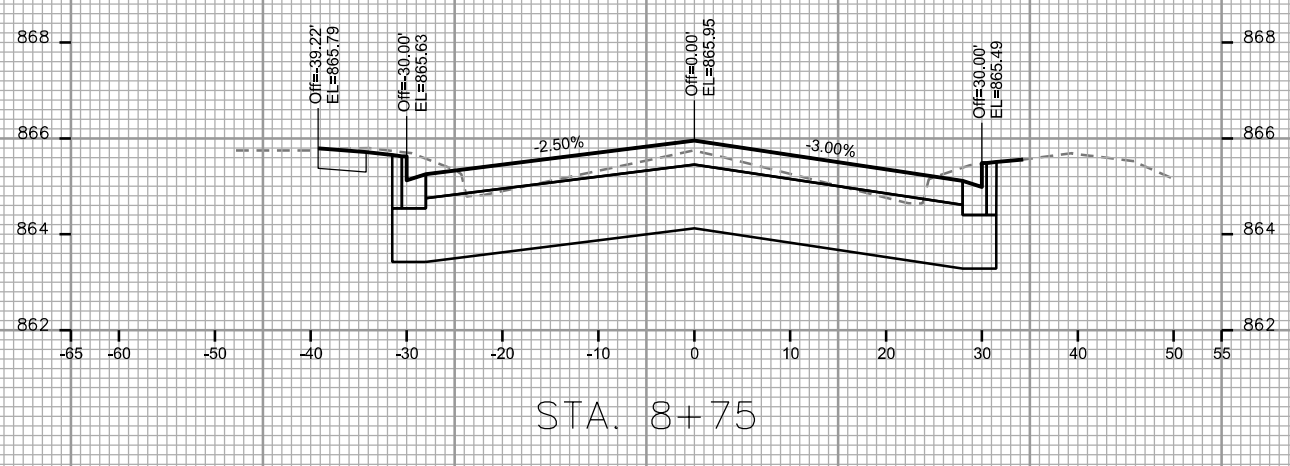
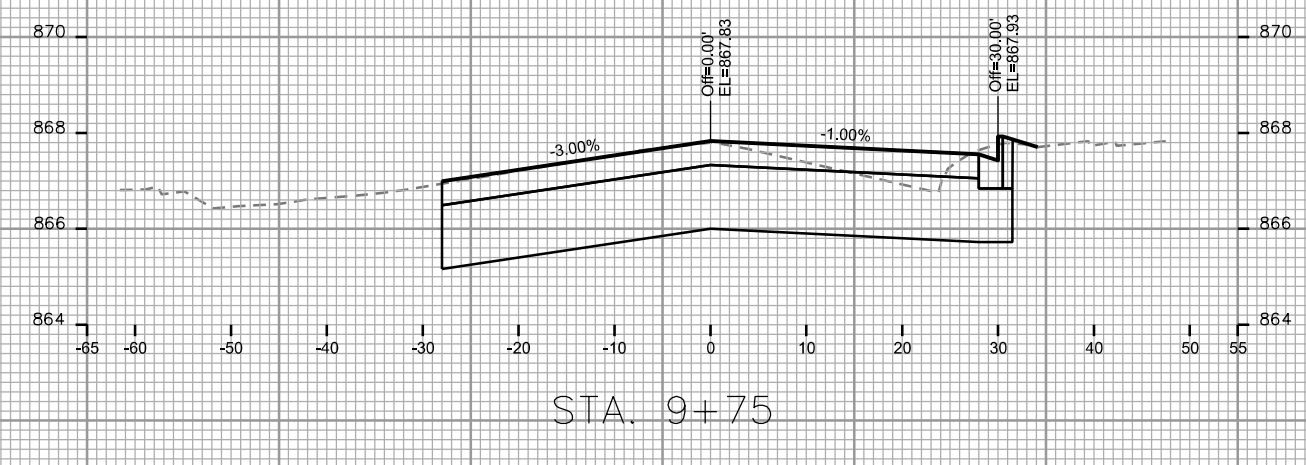
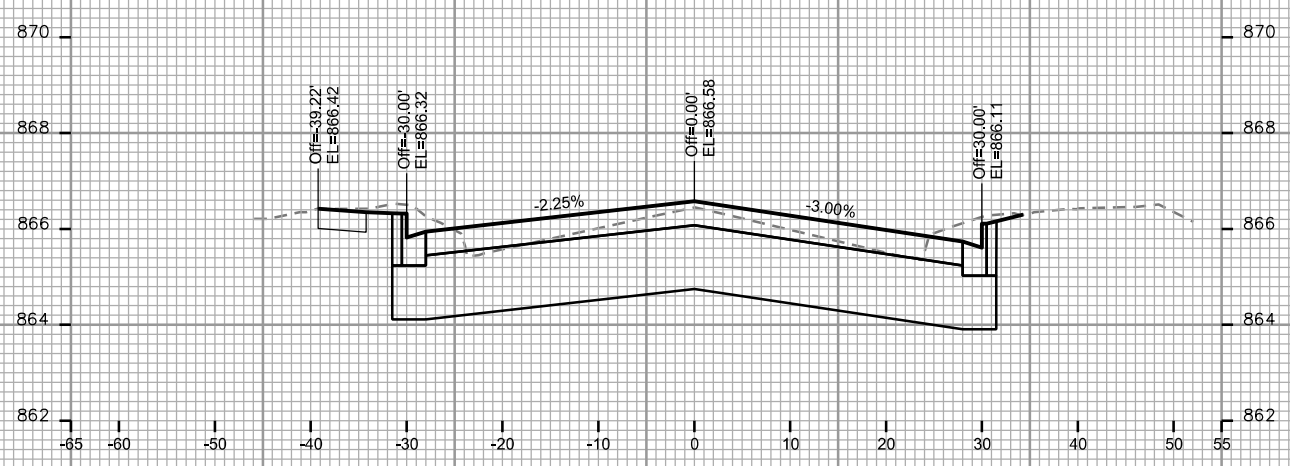
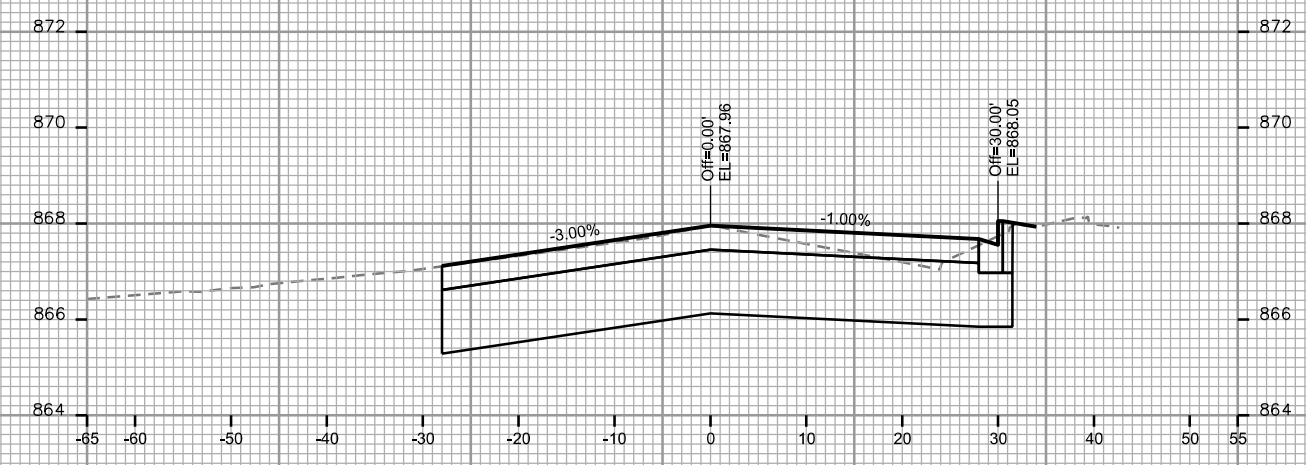
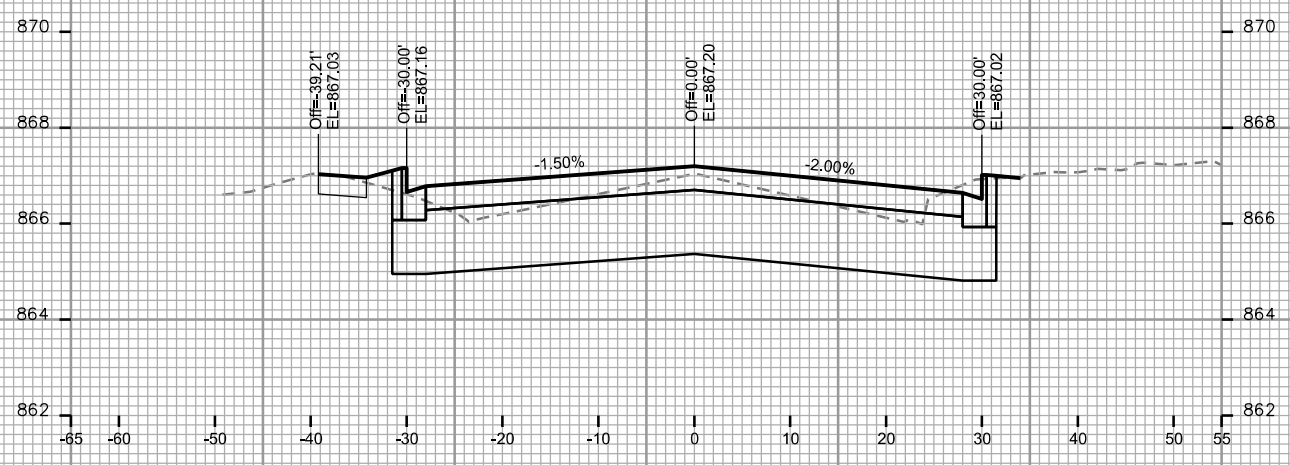

PLOT SCALE: _____

PLOT NAME: _____

REV. DATE: _____

ORIGINATOR: CITY OF MADISON, STREETS DIVISION

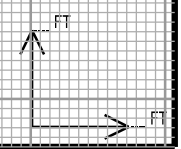
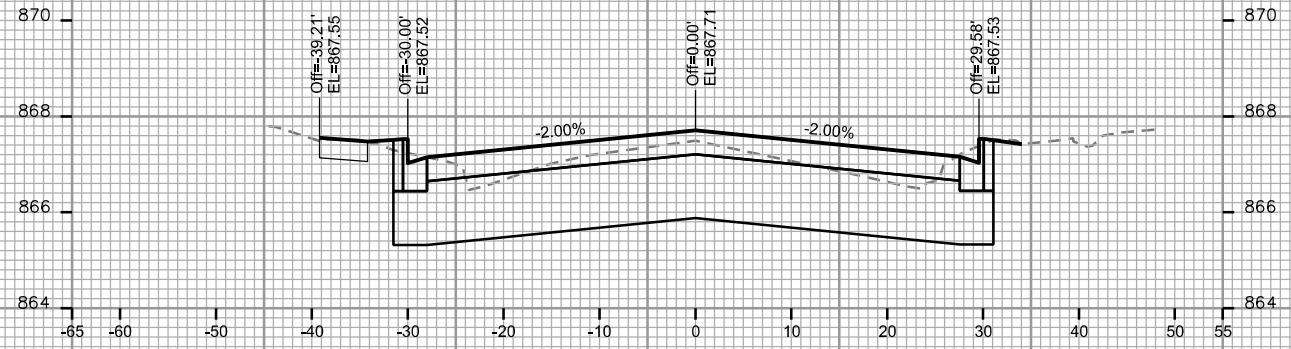
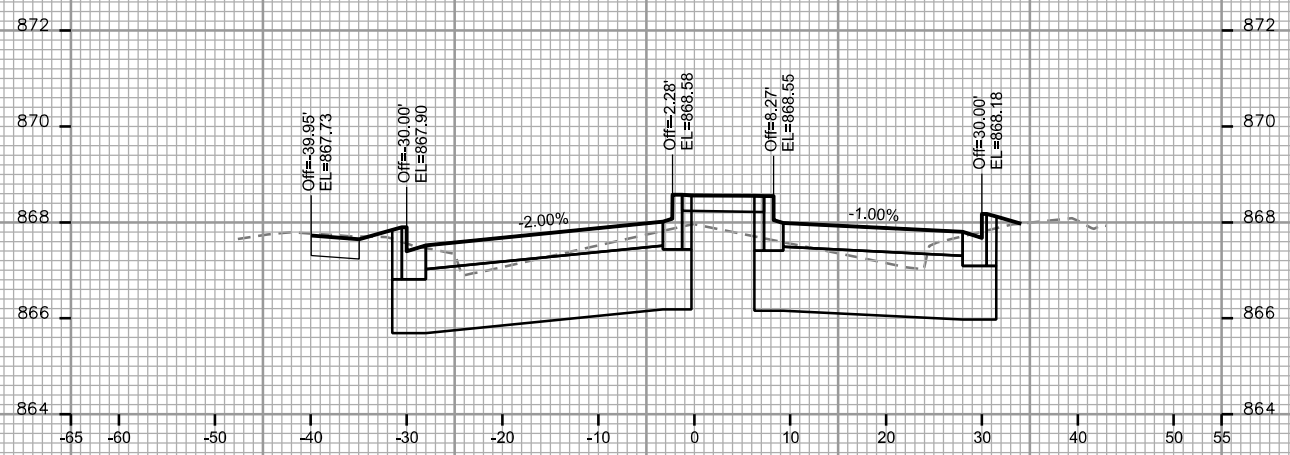
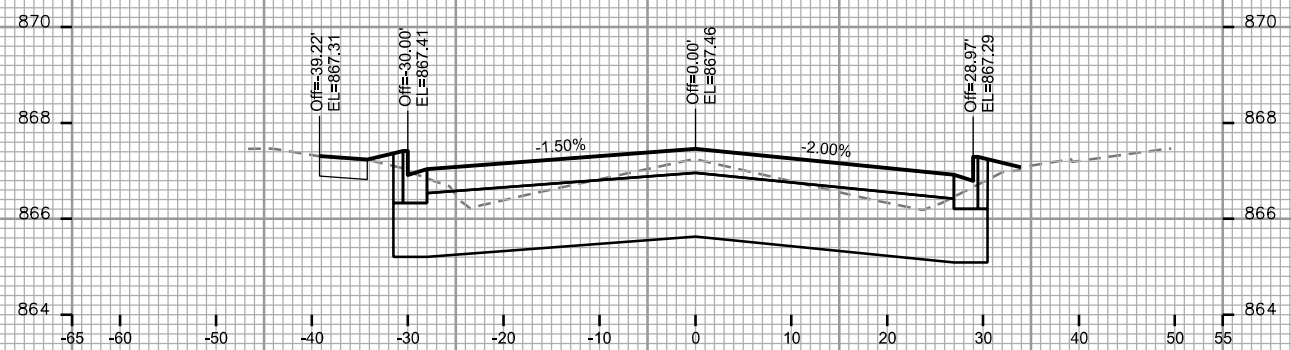
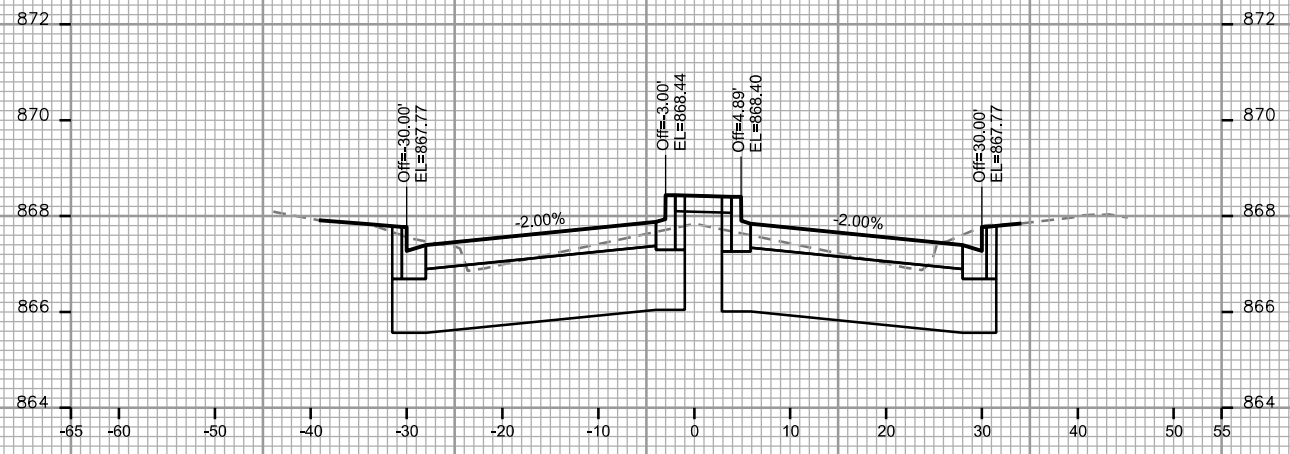
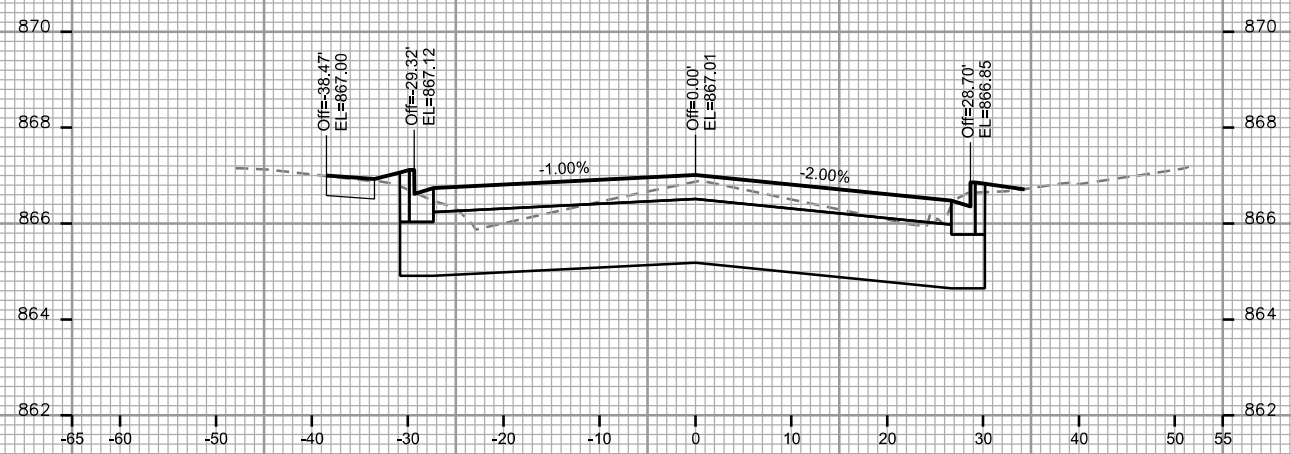
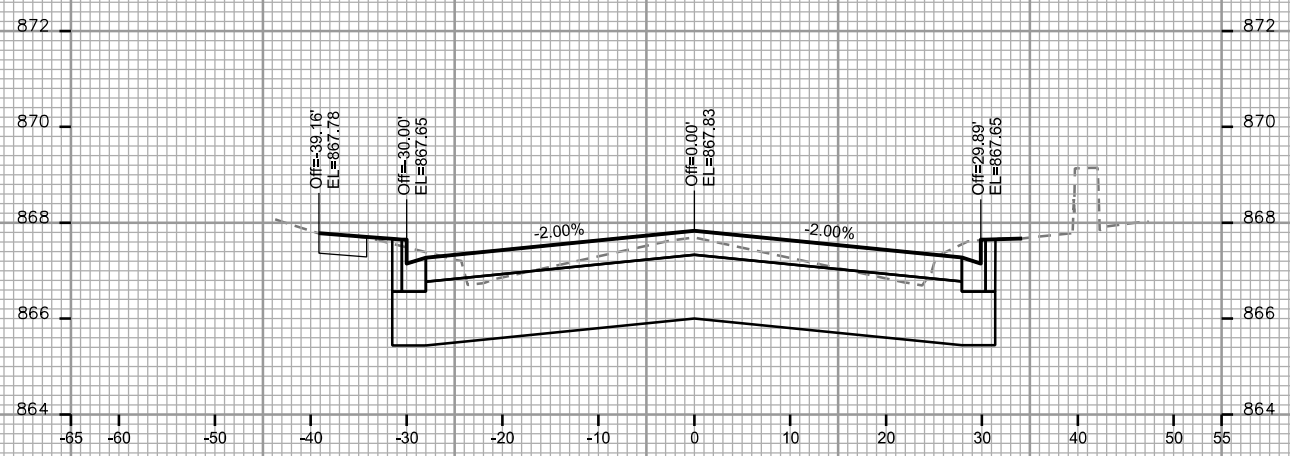

PLOT SCALE: _____

PLOT NAME: _____

REV. DATE: _____

ORIGINATOR: CITY OF MADISON - STREETS DIVISION

CROSS SECTIONS

COTTAGE GROVE ROAD

CITY OF MADISON

PLOT SCALE: _____

PLOT NAME: _____

REV. DATE: _____

ORIGINATOR: CITY OF MADISON, STREETS DIVISION

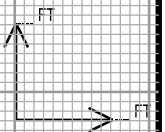
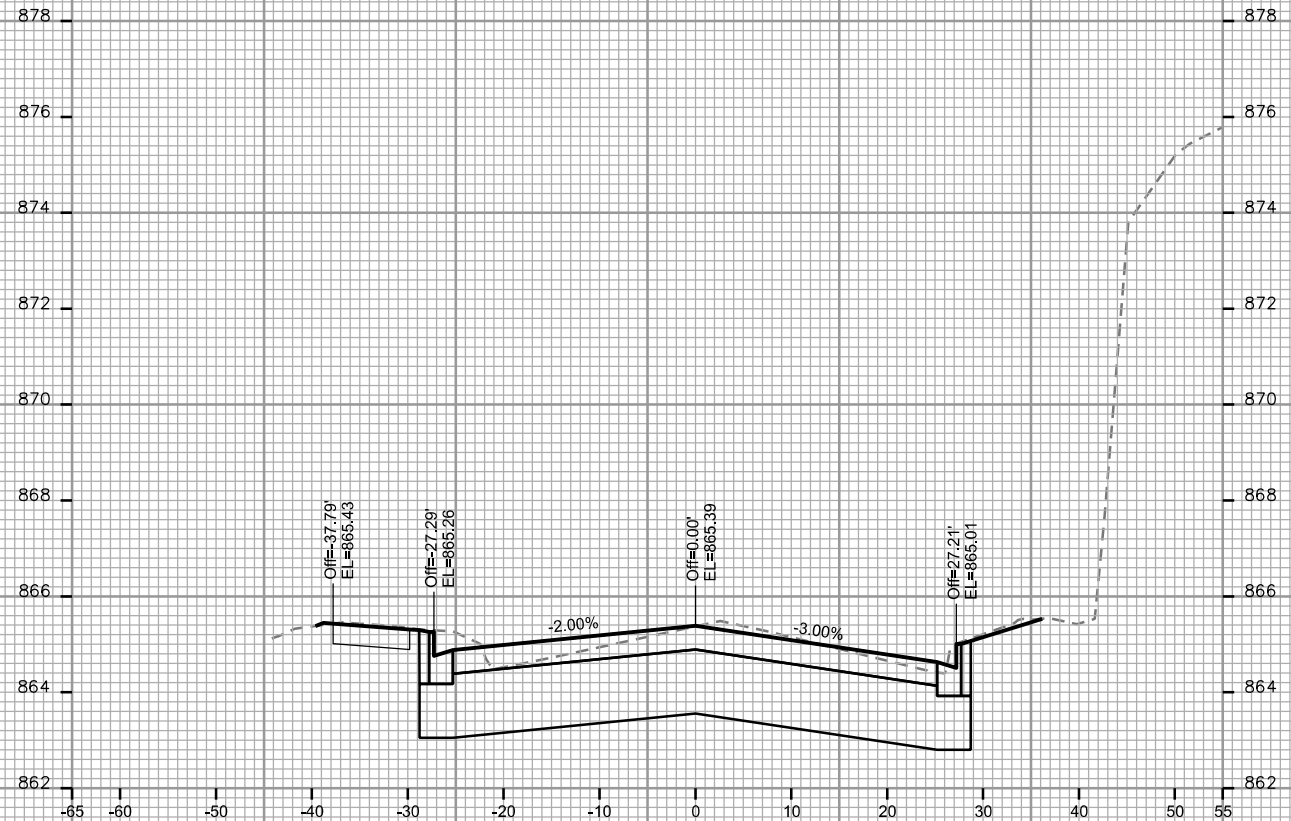
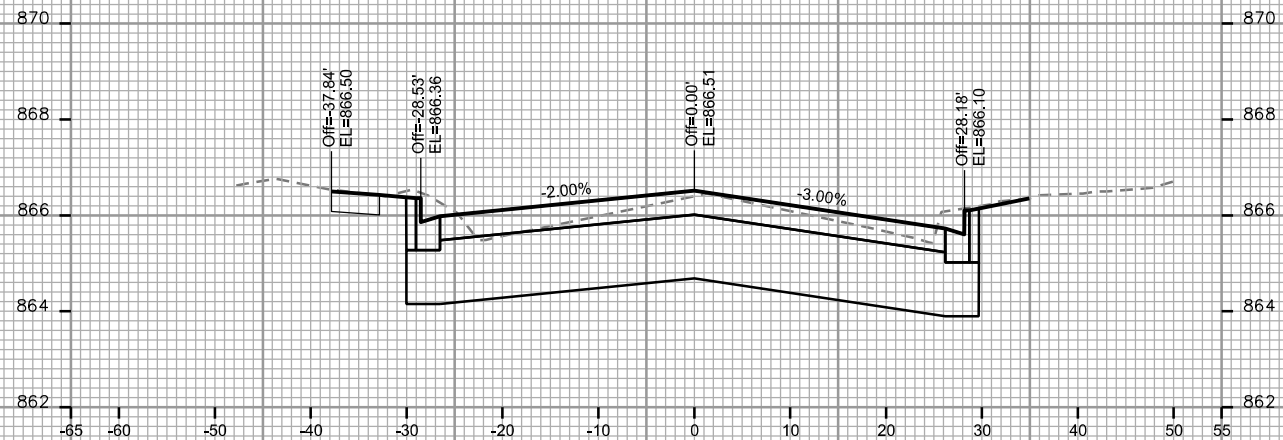
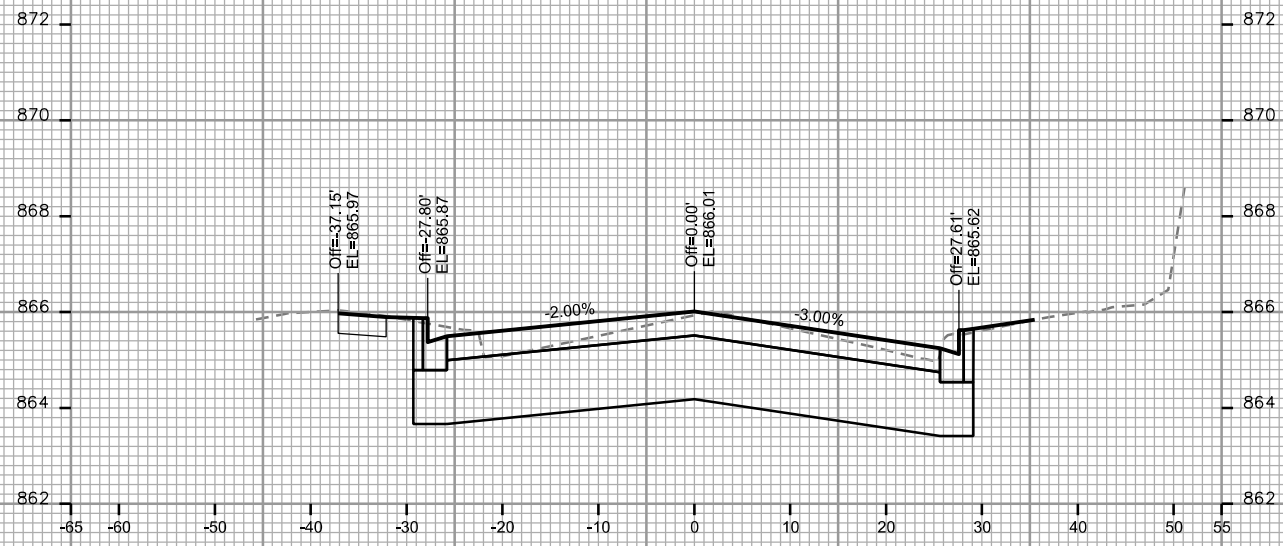

PLOT SCALE: _____

PLOT NAME: _____

REV. DATE: _____

ORIGINATOR: CITY OF MADISON - STREETS DIVISION

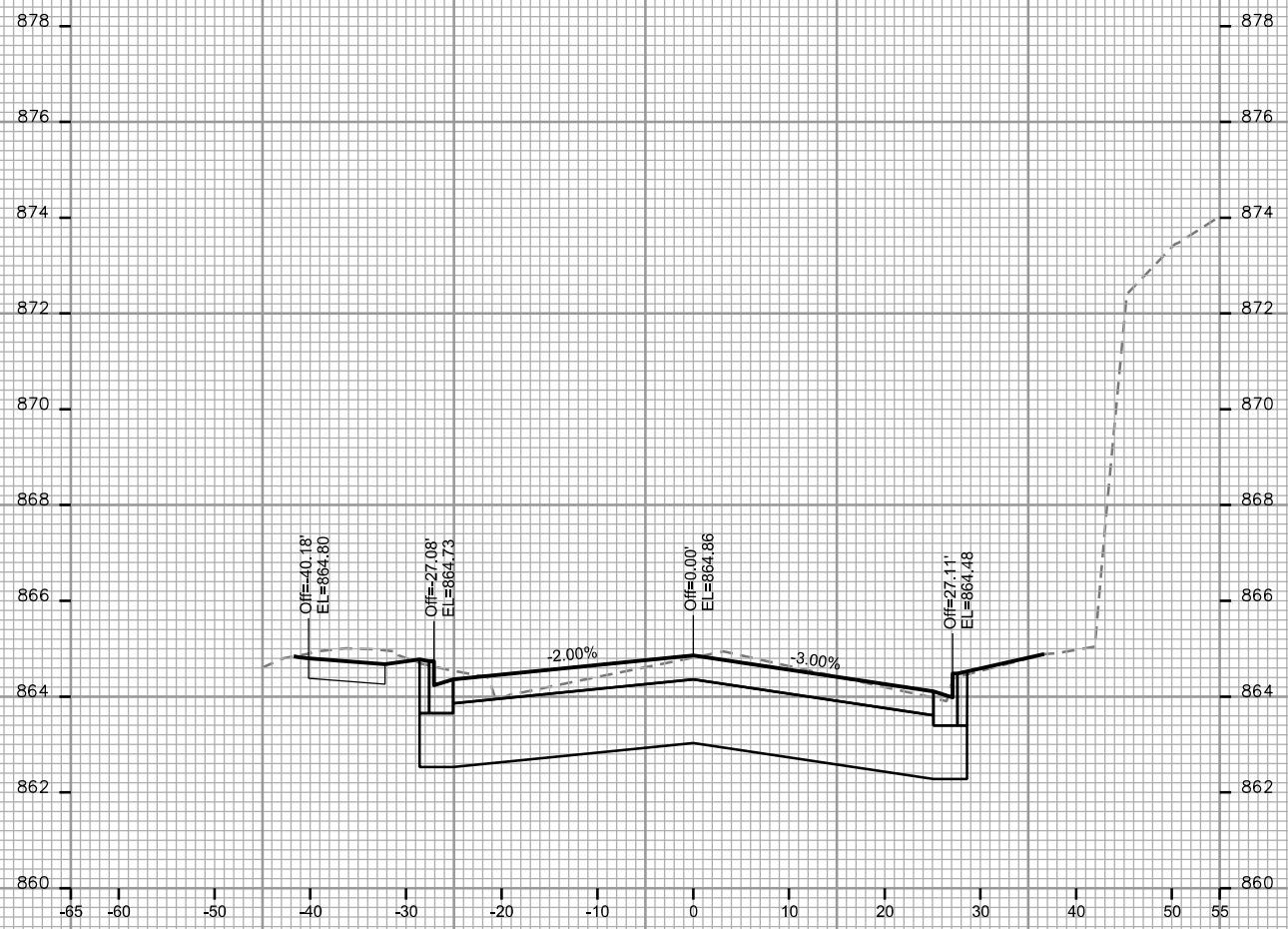

STA. 12+50

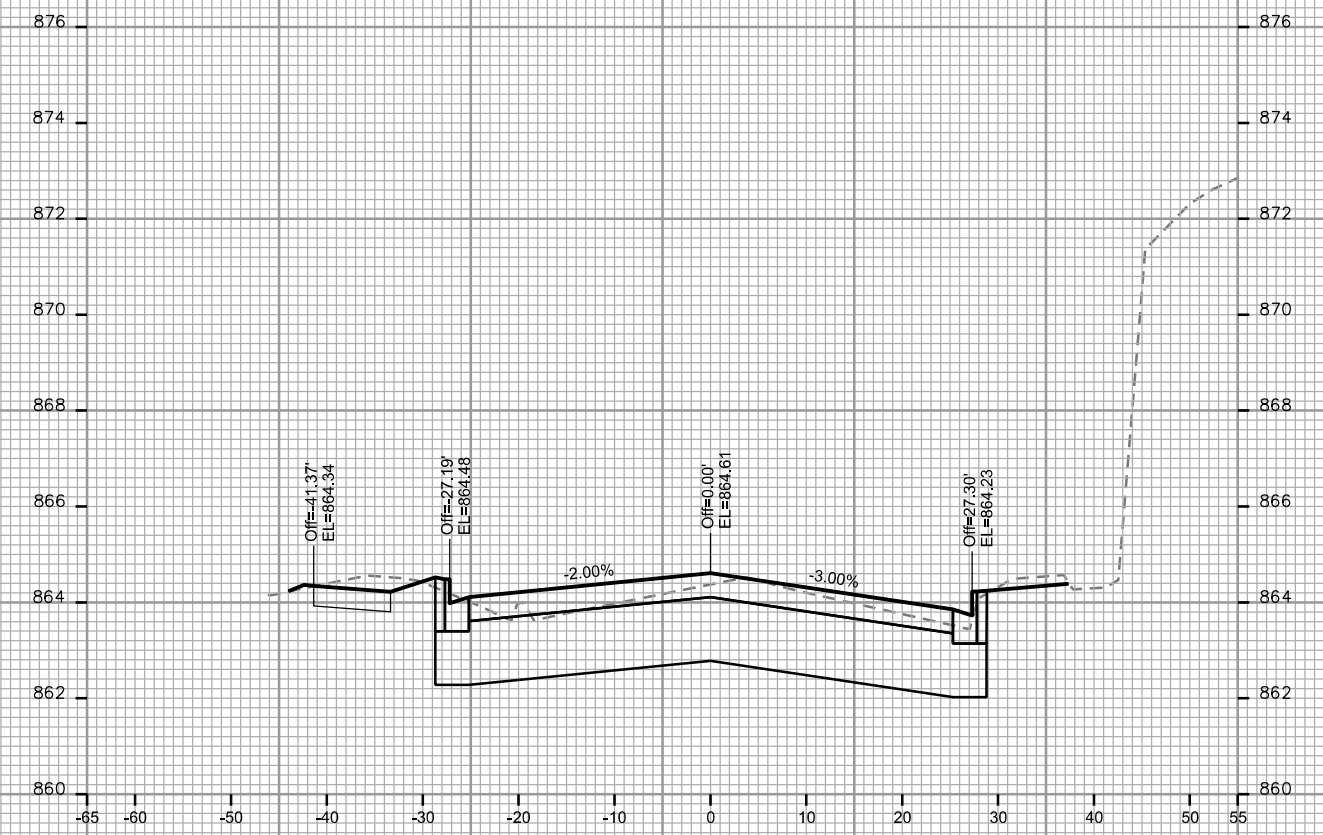

STA. 12+75

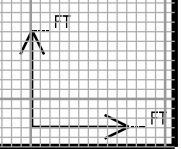

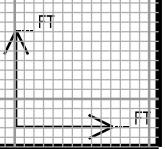
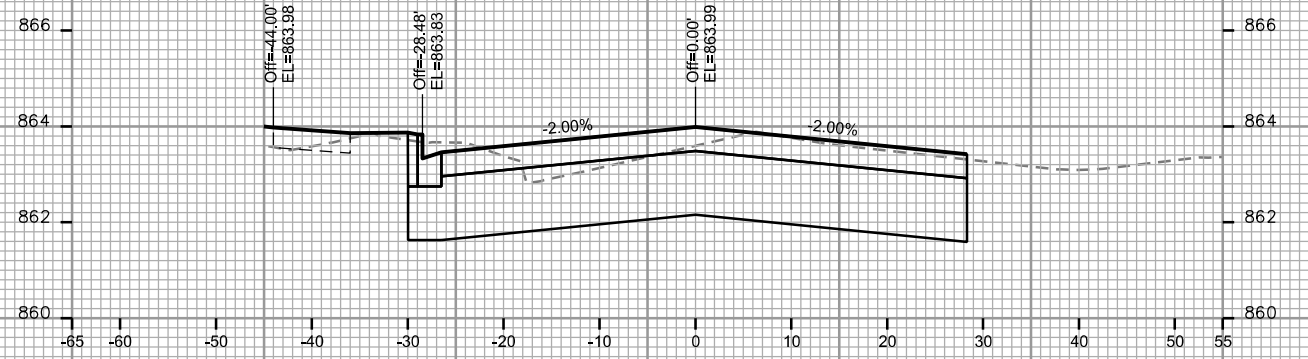
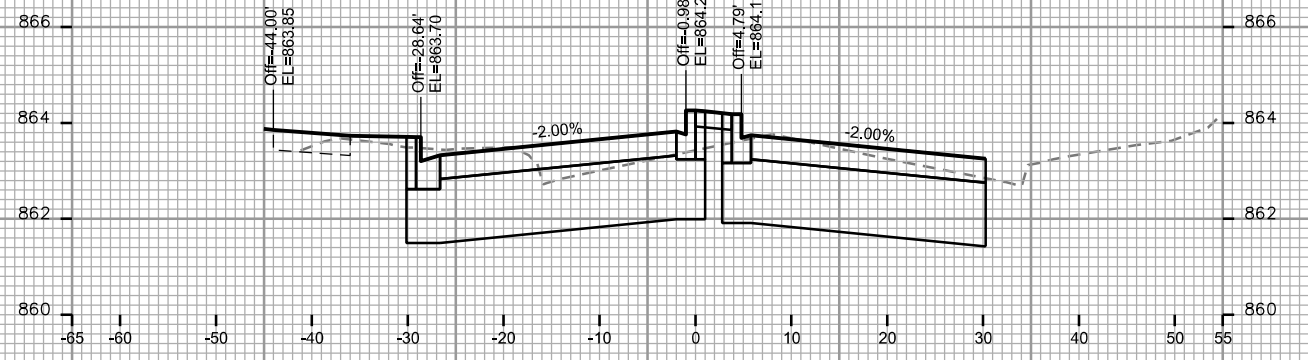
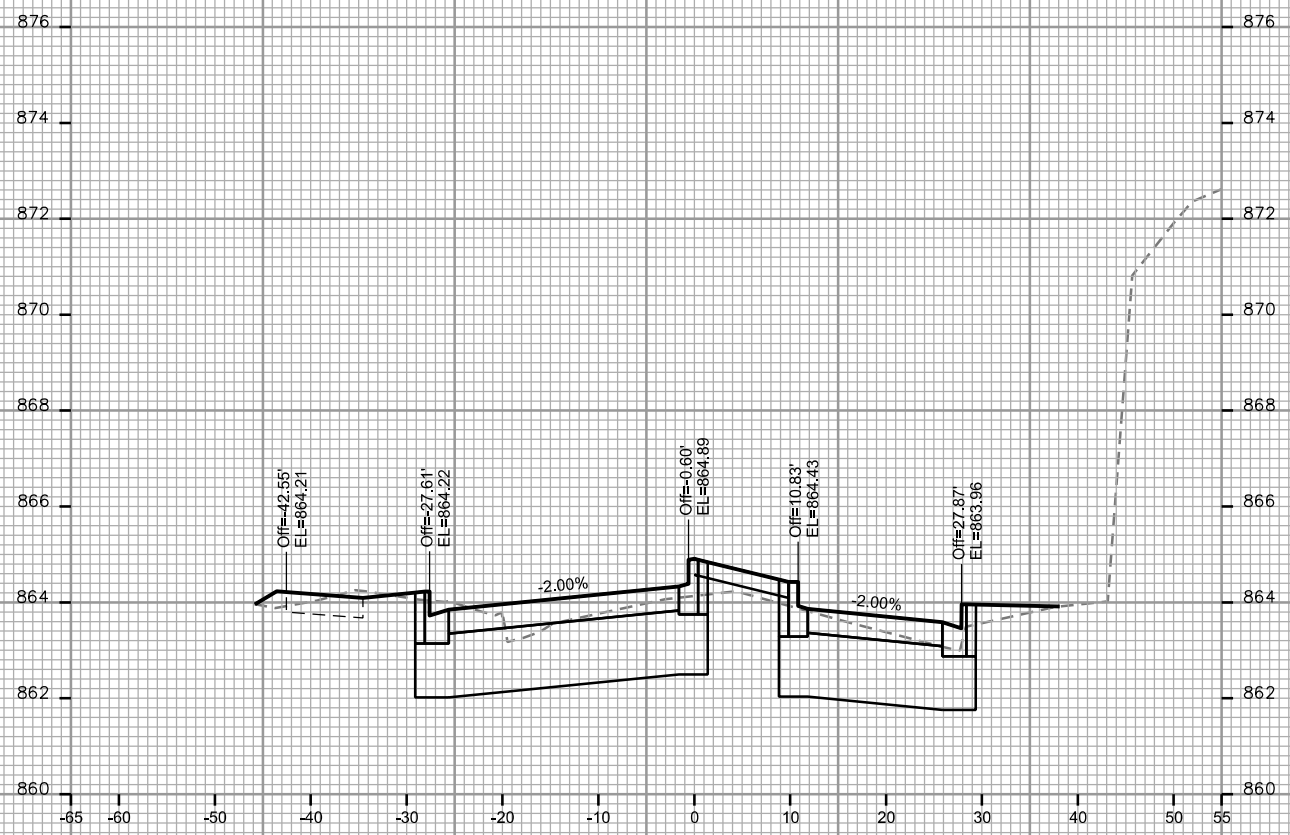
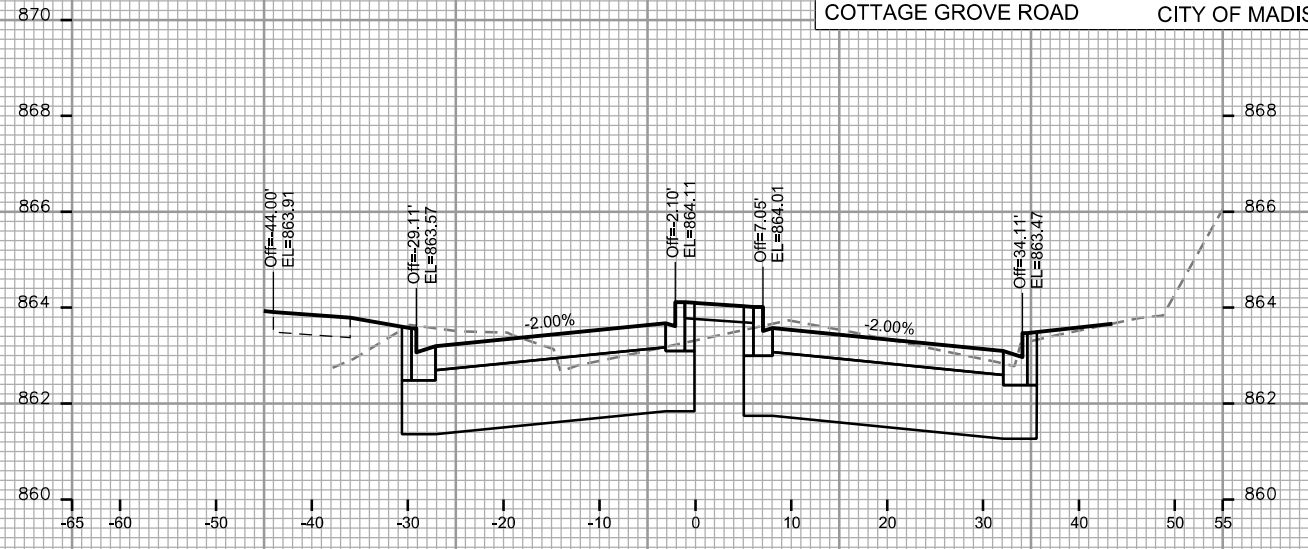
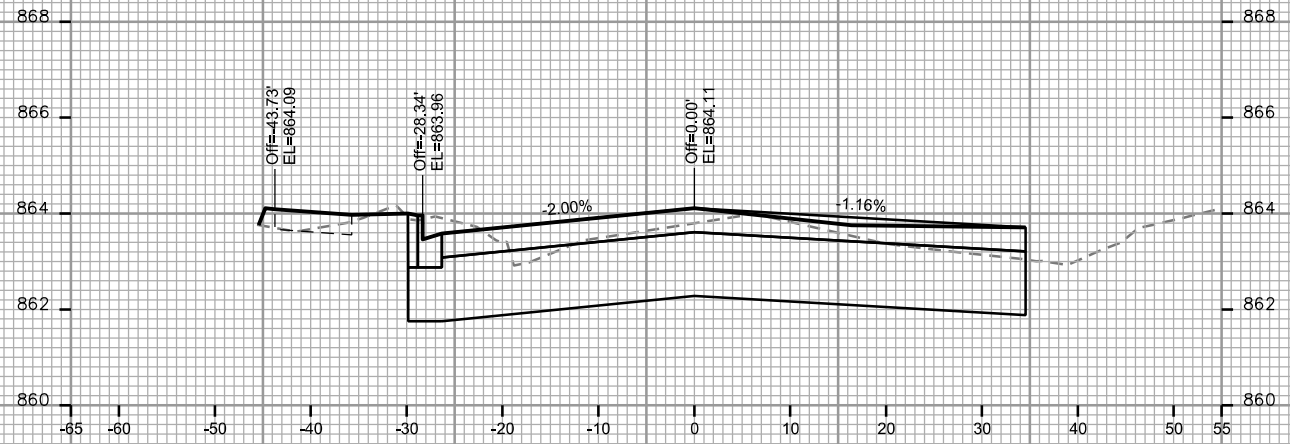

PLOT SCALE: _____

PLOT NAME: _____

REV. DATE: _____

ORIGINATOR: CITY OF MADISON, STREETS DIVISION

PLOT SCALE: _____

PLOT NAME: _____

REV. DATE: _____

ORIGINATOR: CITY OF MADISON - STREETS DIVISION

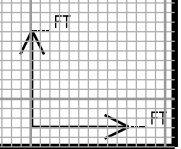
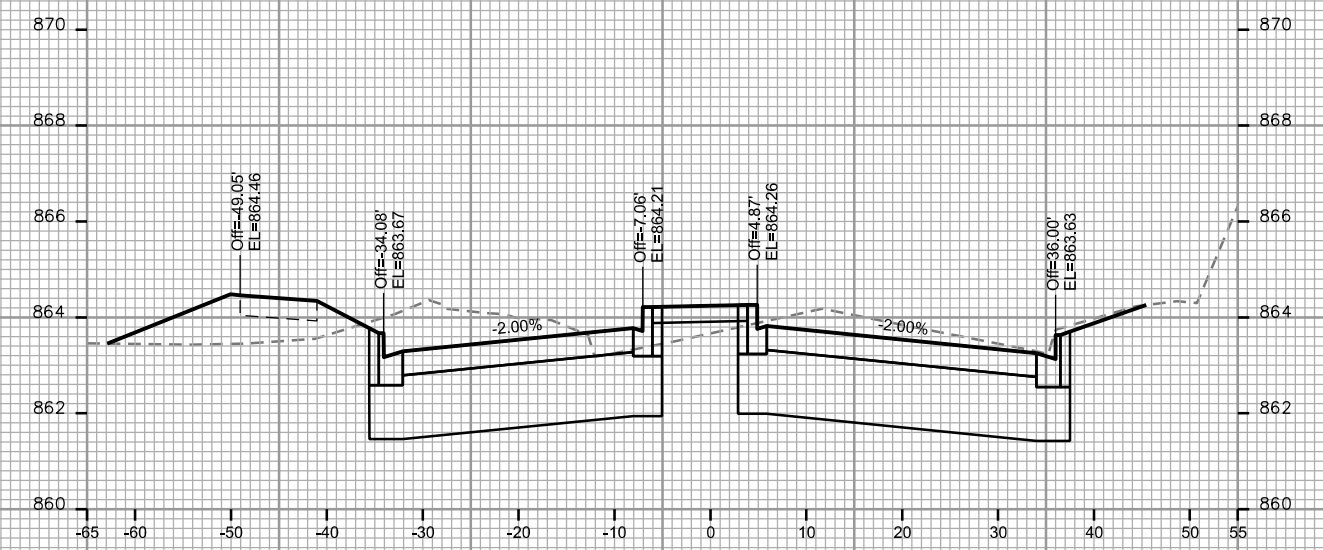
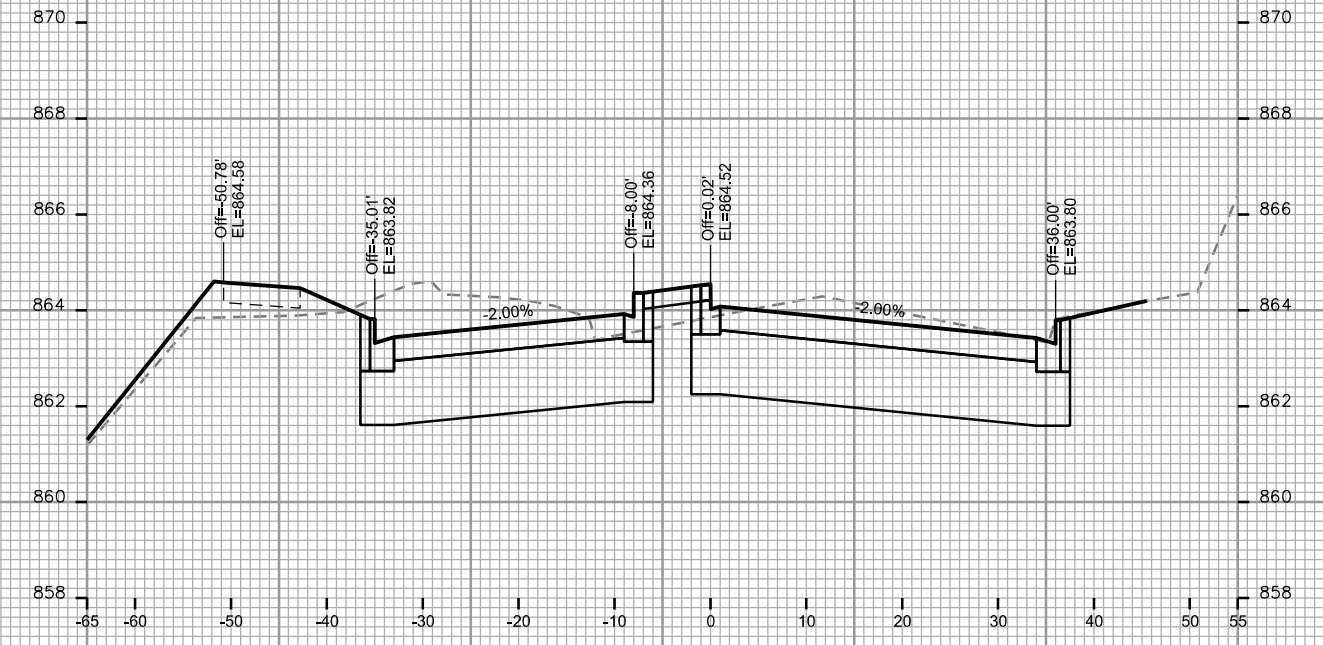
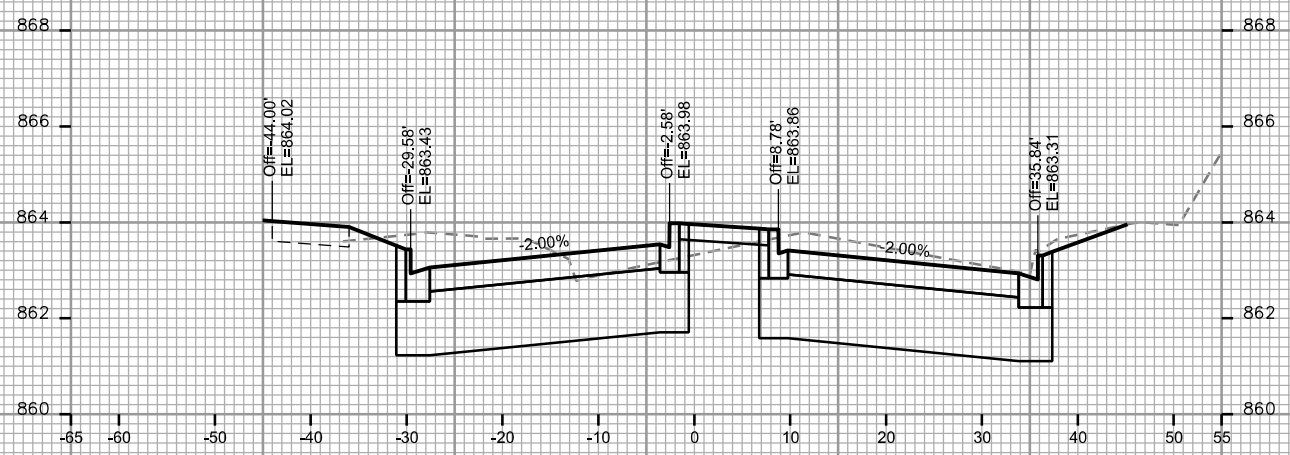
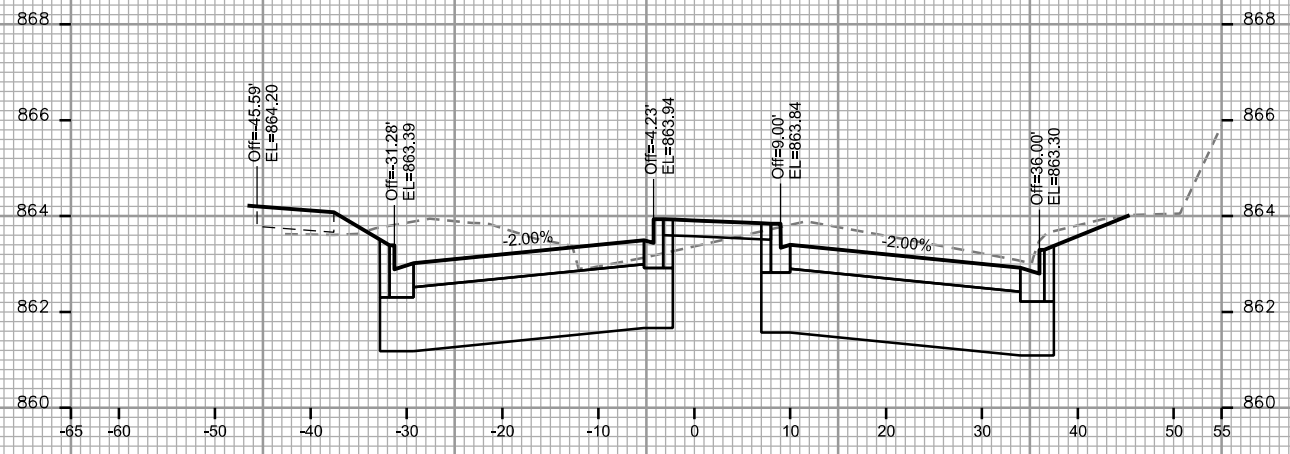
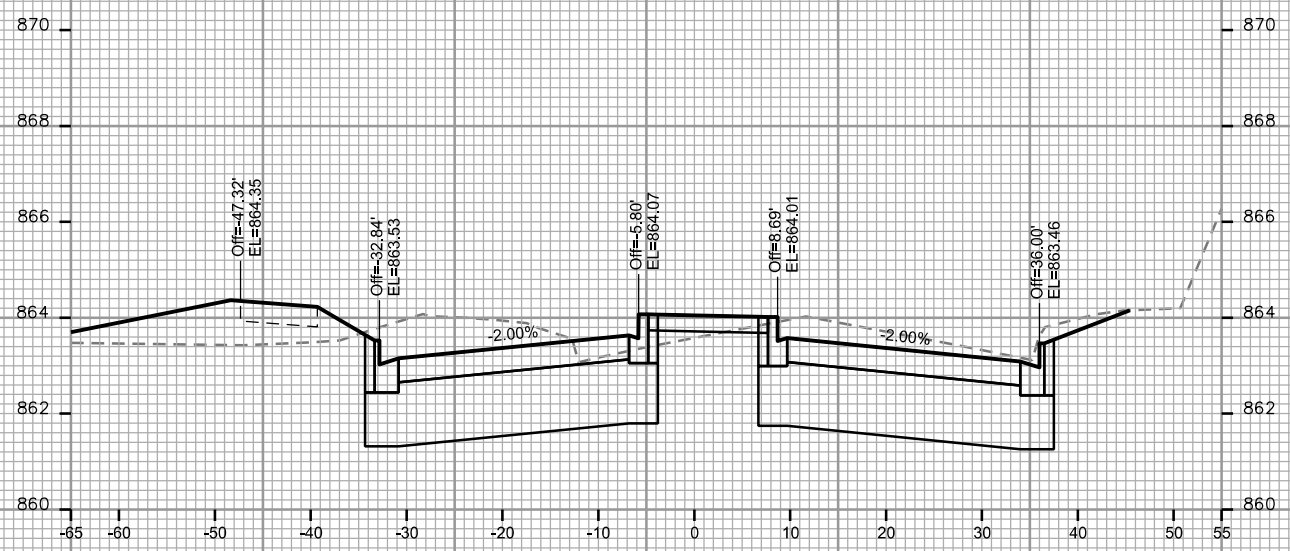

PLOT SCALE: _____

PLOT NAME: _____

REV. DATE: _____

ORIGINATOR: CITY OF MADISON, STREETS DIVISION

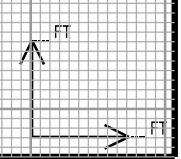
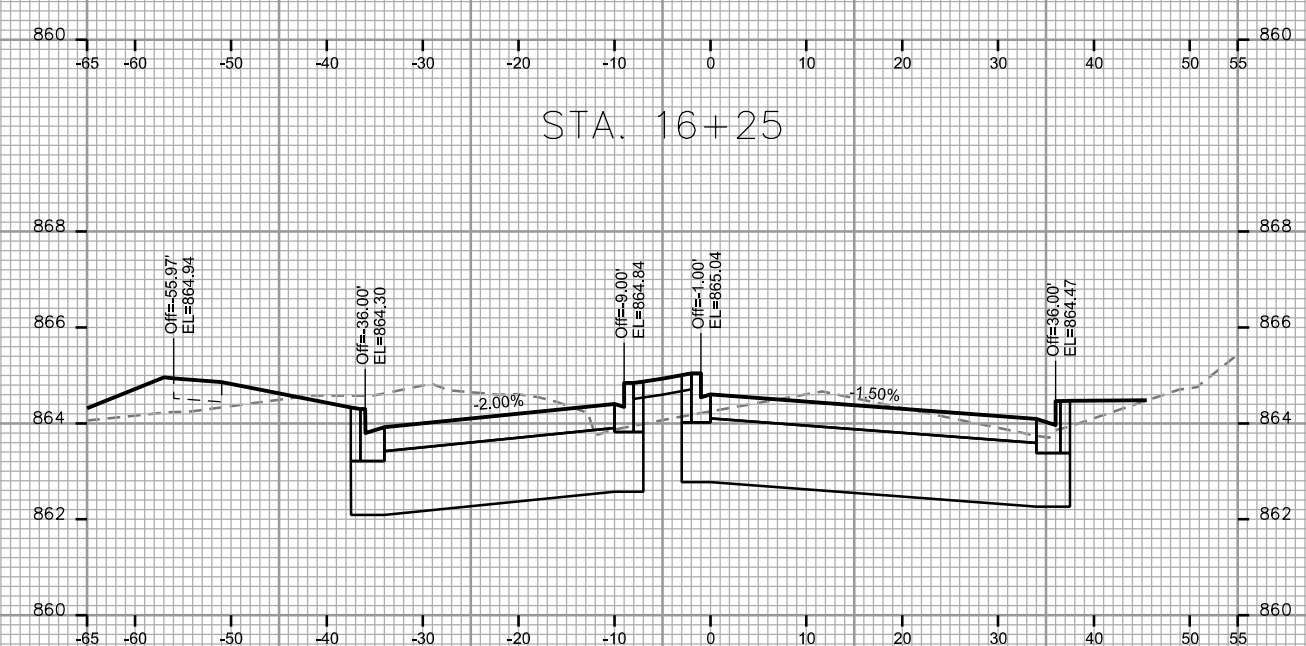
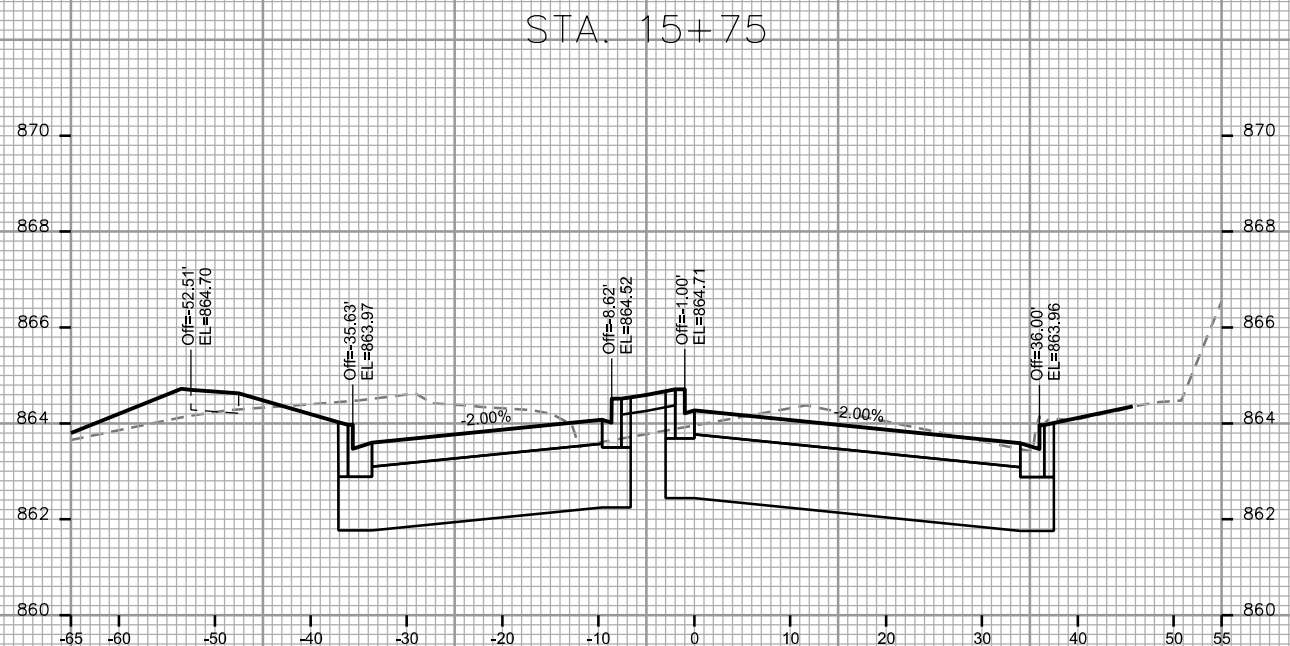
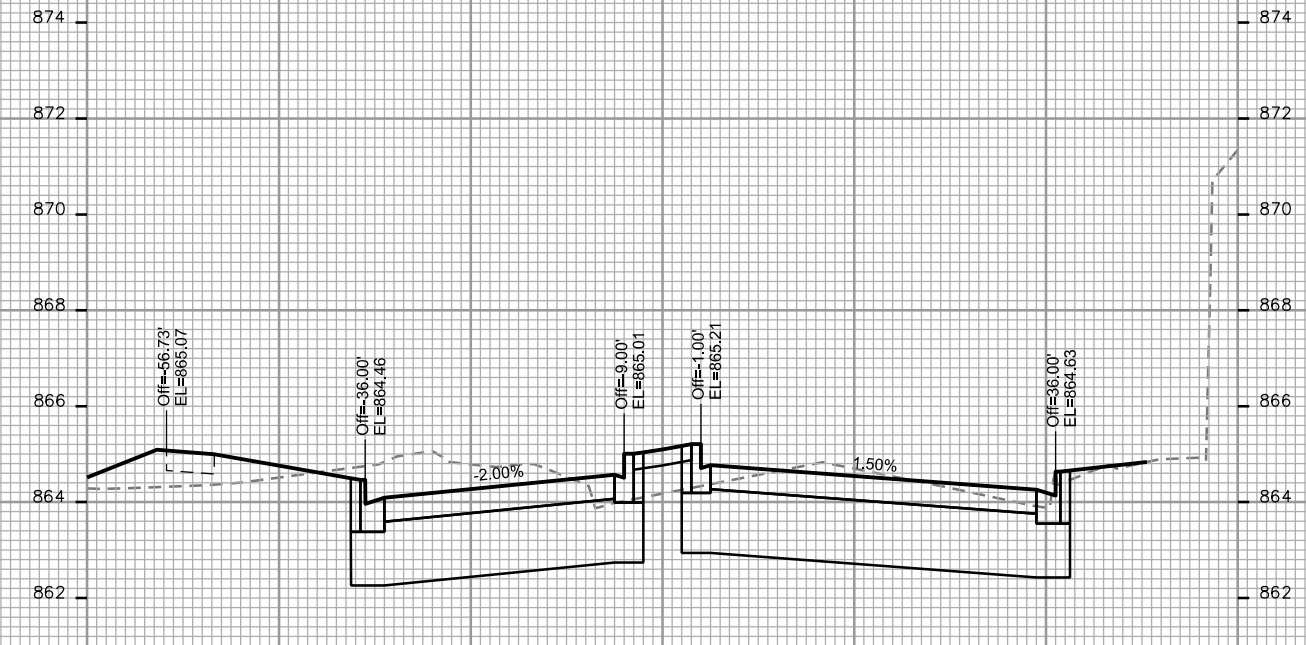
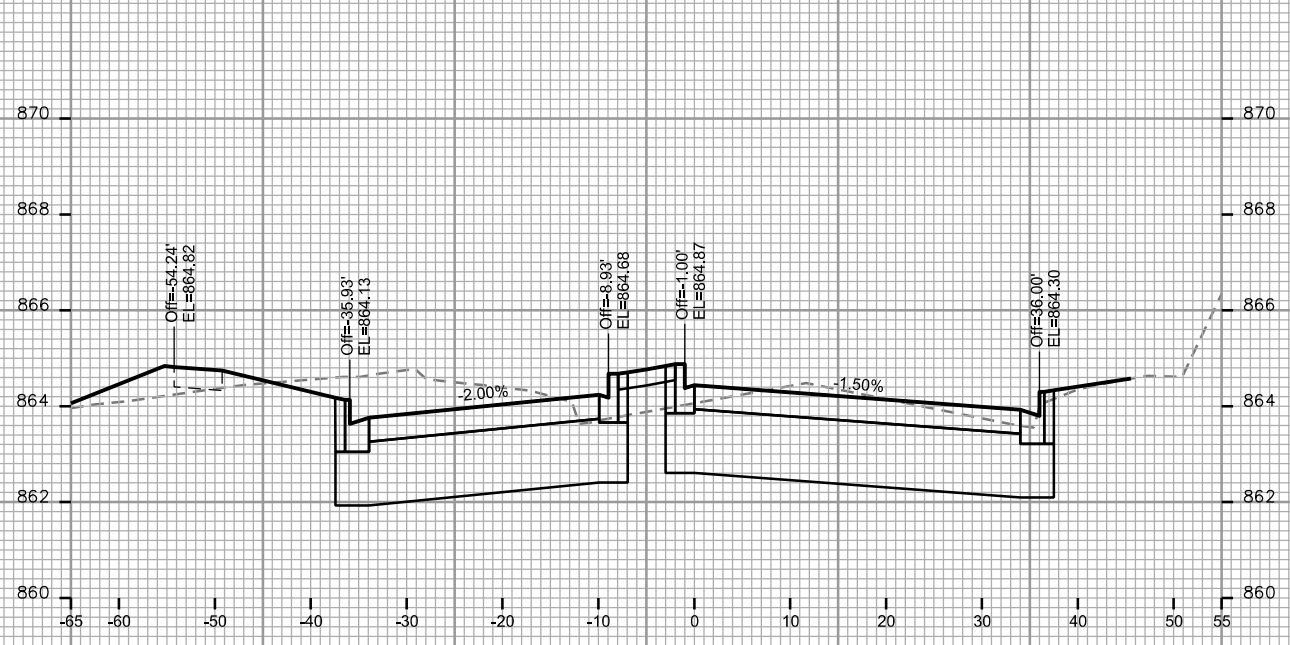

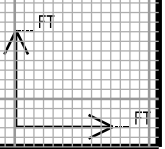
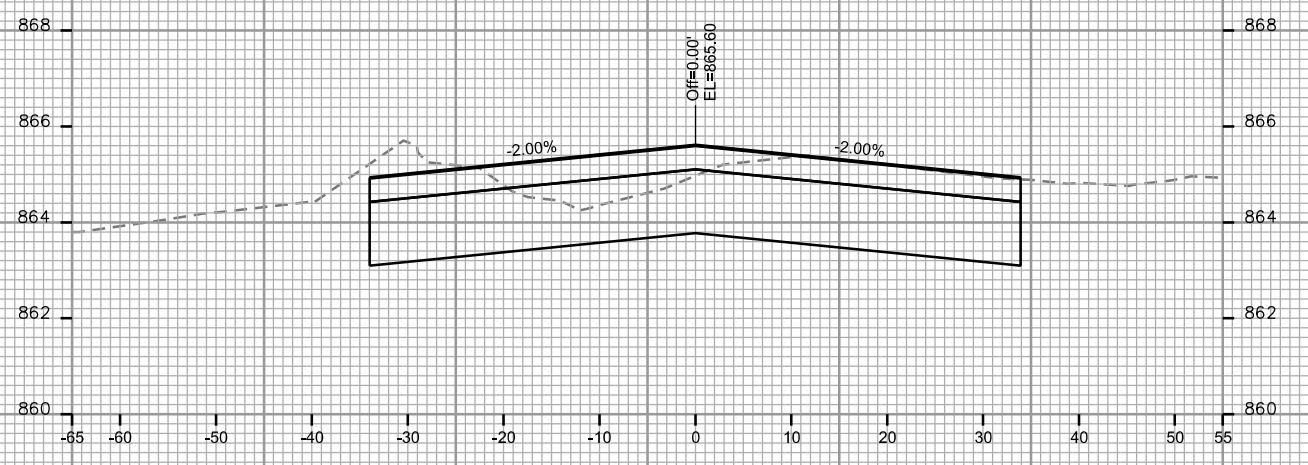
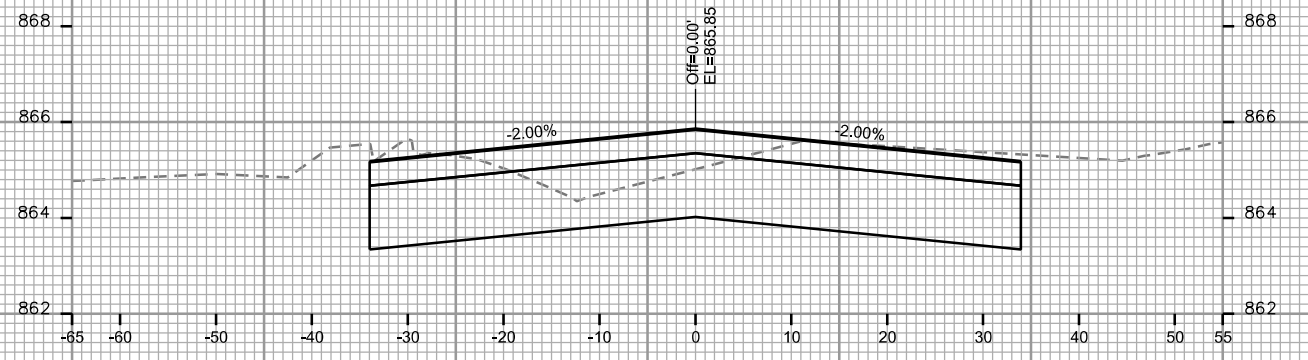
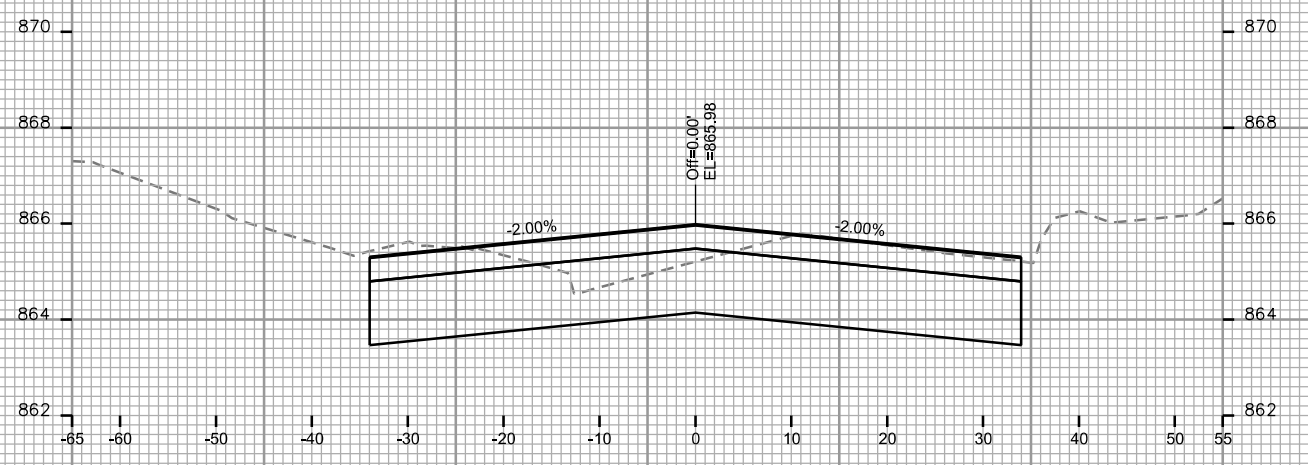
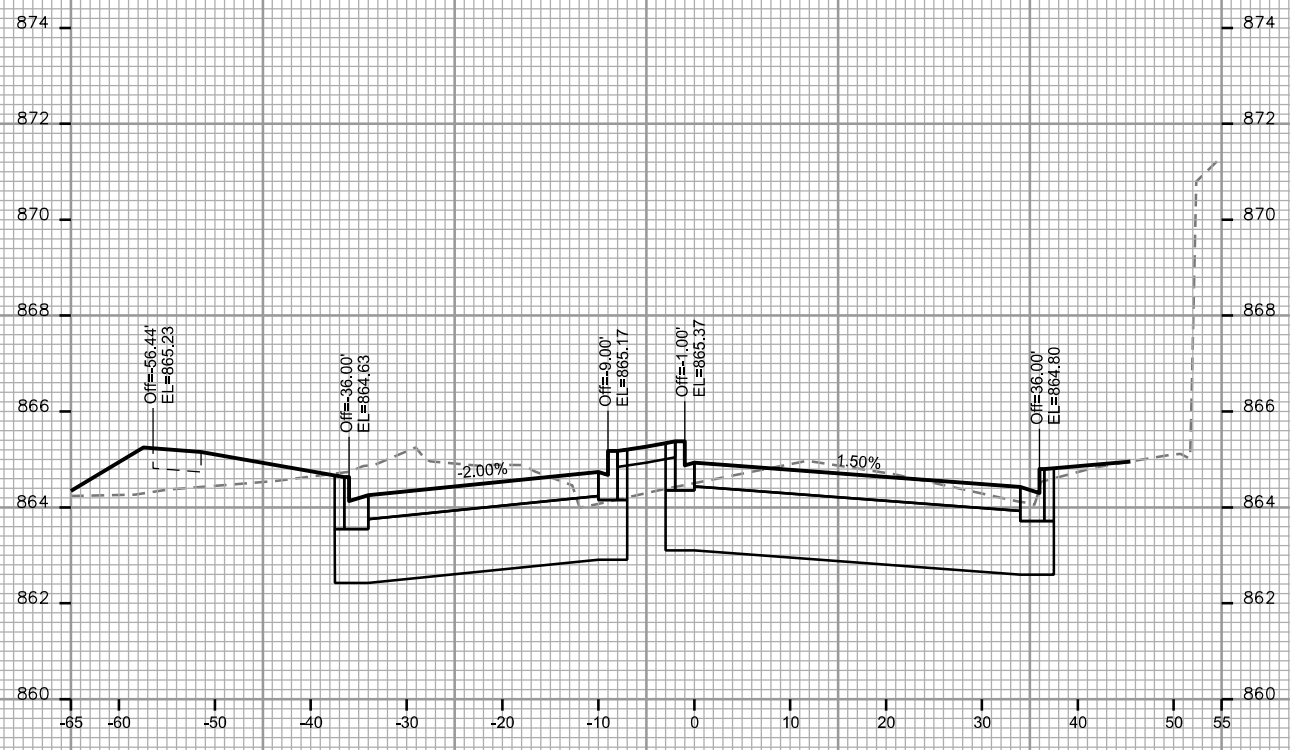

PLOT SCALE: _____

PLOT NAME: _____

REV. DATE: _____

ORIGINATOR: CITY OF MADISON - STREETS DIVISION

CROSS SECTIONS

COTTAGE GROVE ROAD

CITY OF MADISON

PLOT SCALE: _____

PLOT NAME: _____

REV. DATE: _____

ORIGINATOR: CITY OF MADISON - STREETS DIVISION

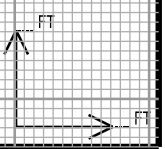
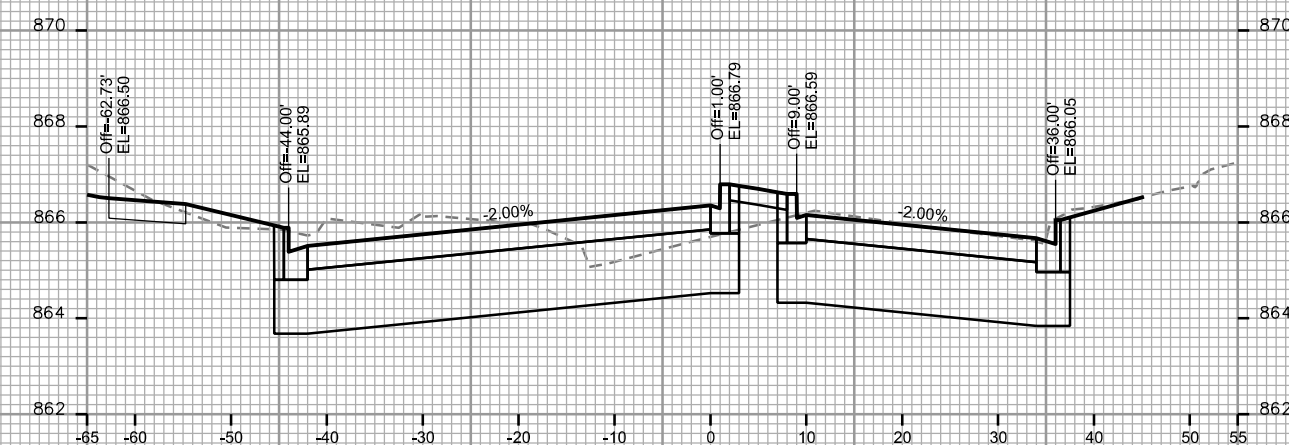
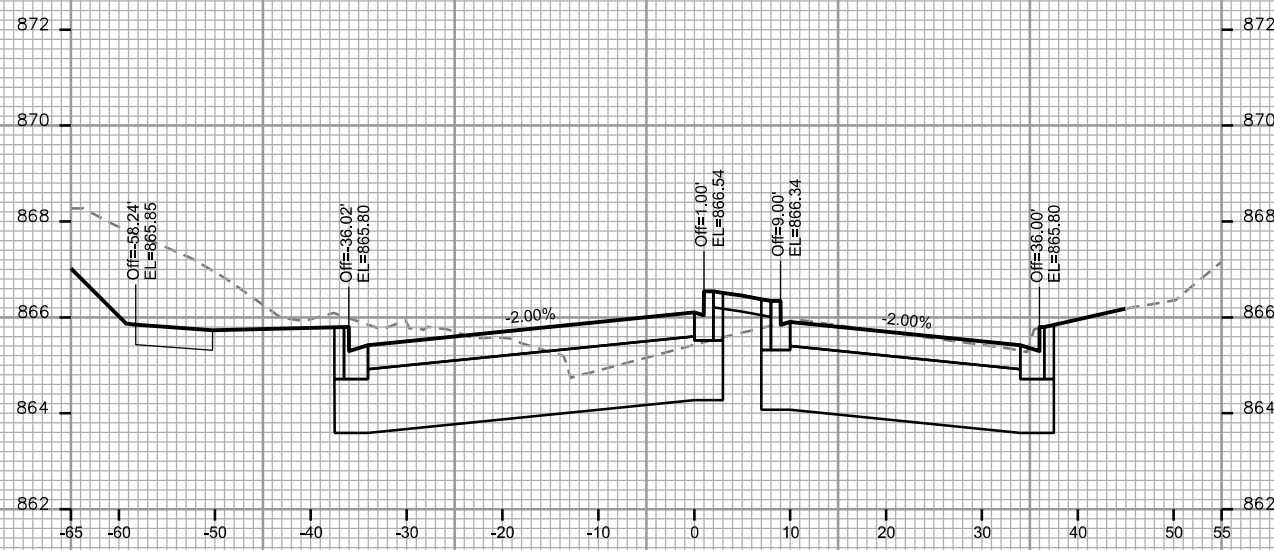
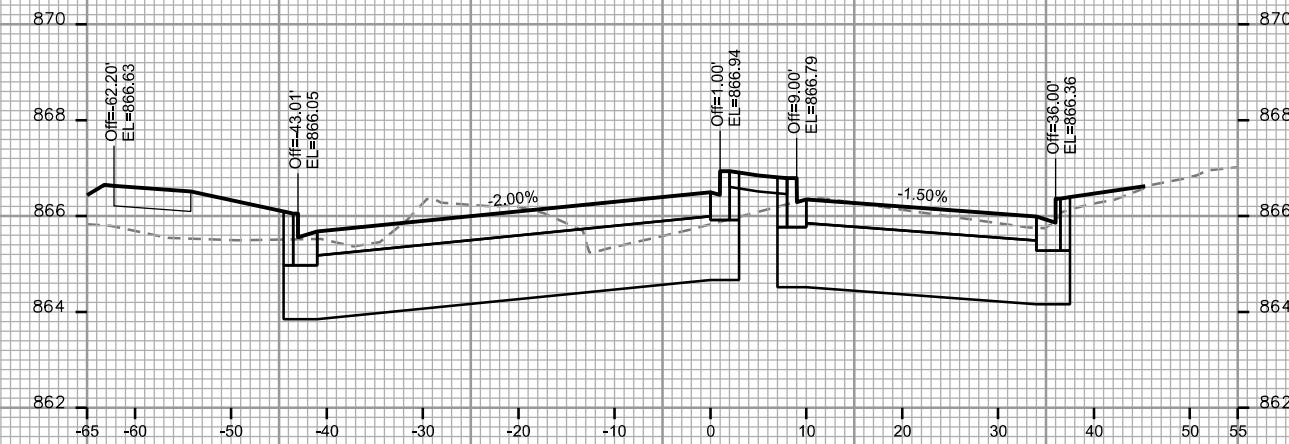
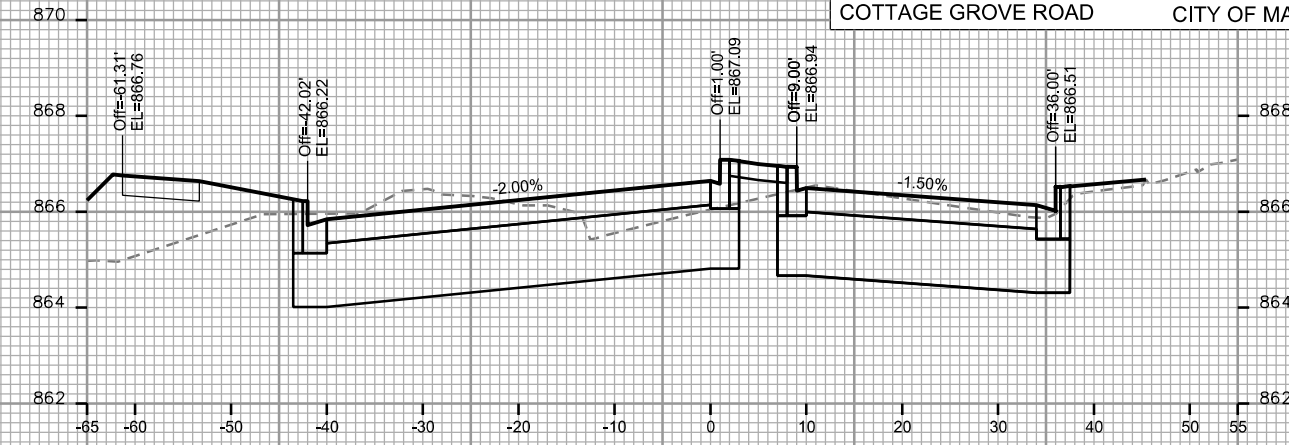
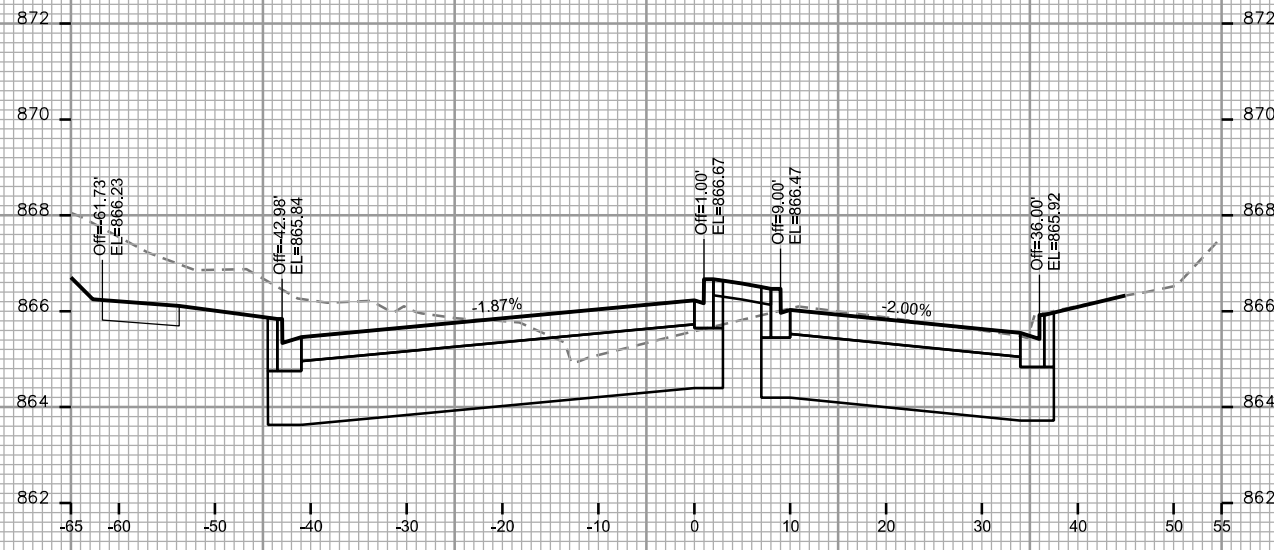

CROSS SECTIONS
COTTAGE GROVE ROAD CITY OF MADISON

PLOT SCALE: _____

REV. DATE: _____

ORIGINATOR: CITY OF MADISON STREETS DIVISION

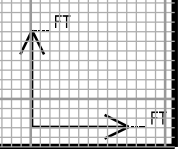
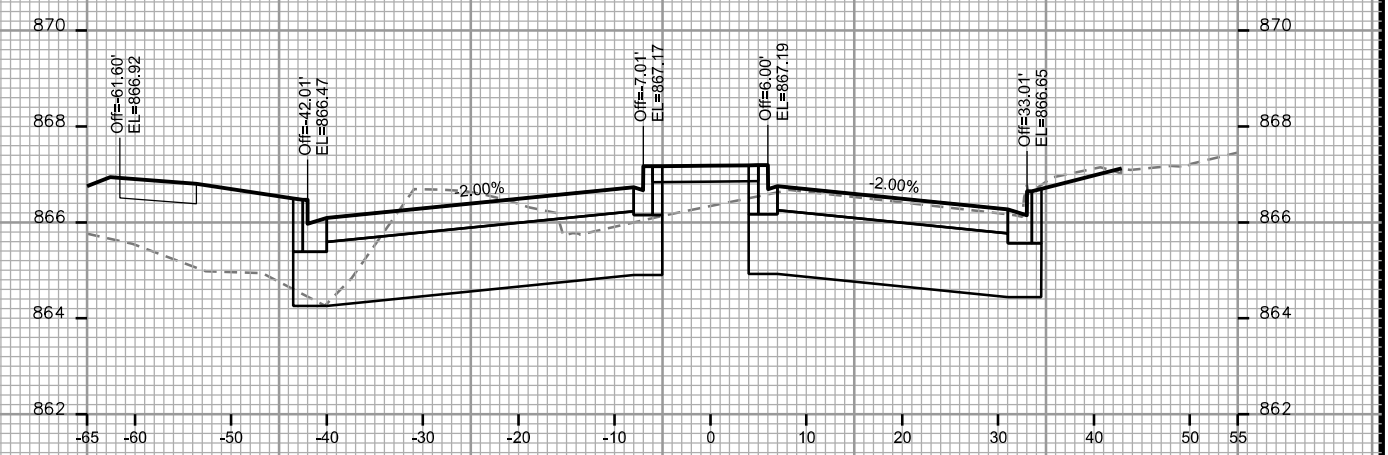
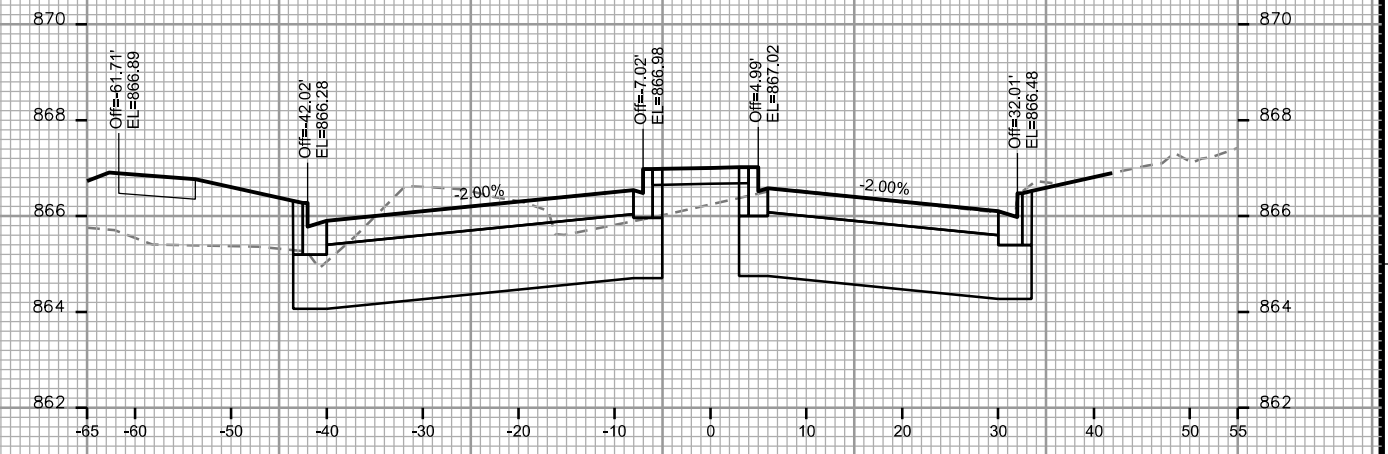
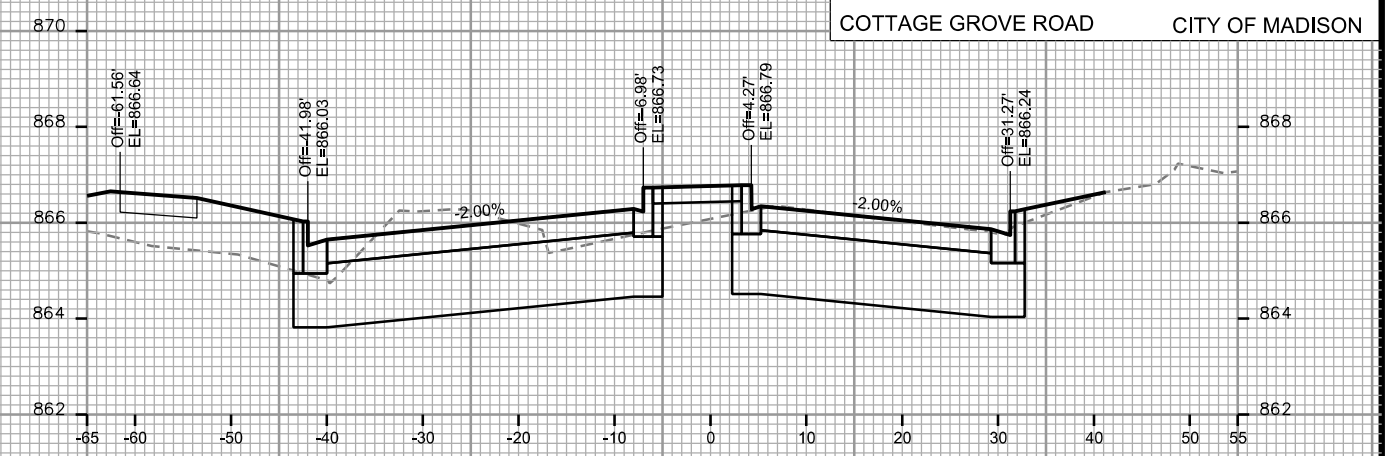
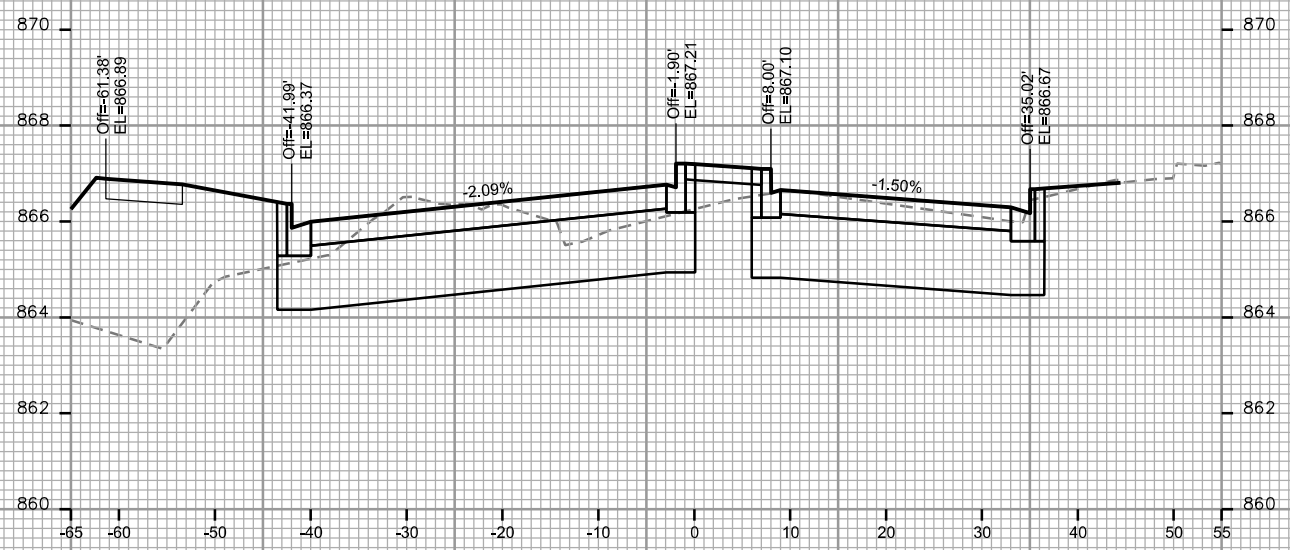
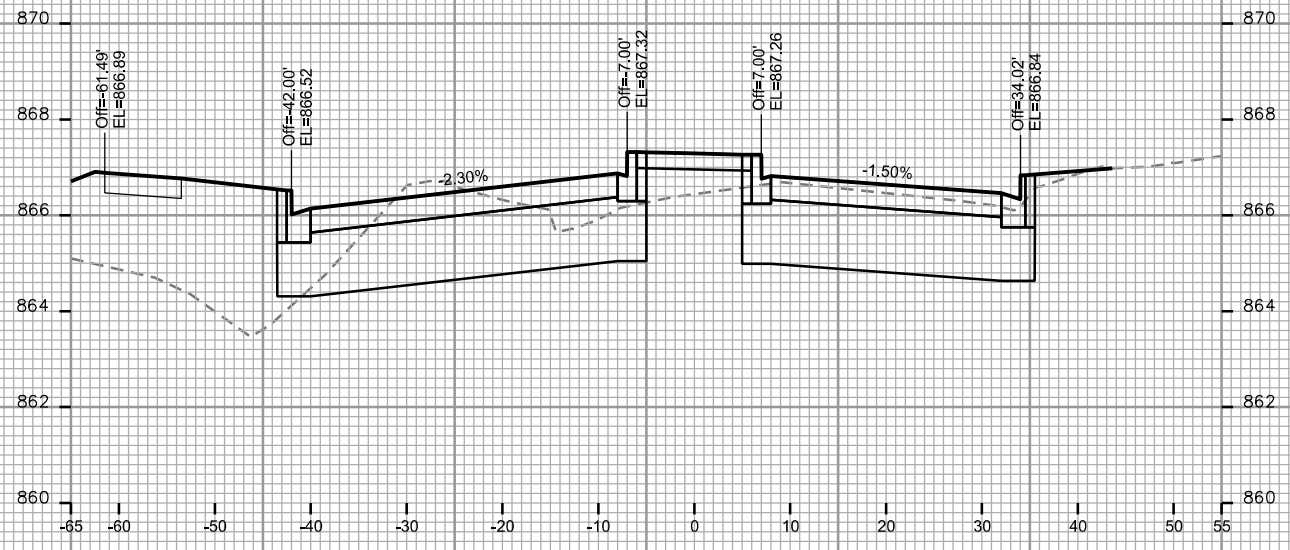

CROSS SECTIONS
COTTAGE GROVE ROAD CITY OF MADISON

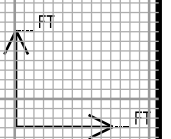
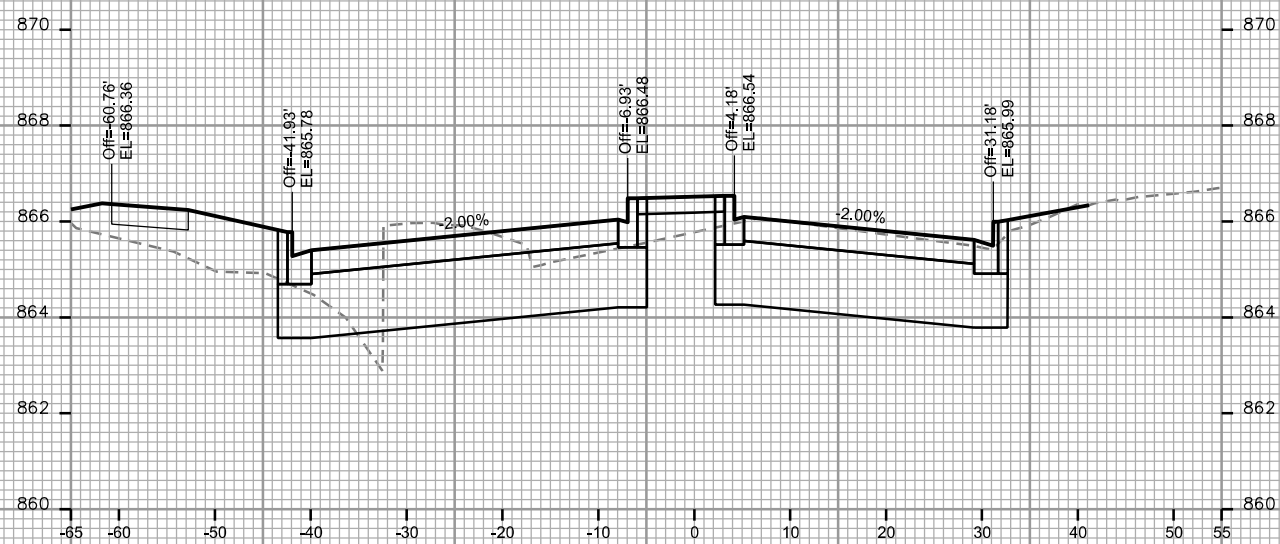
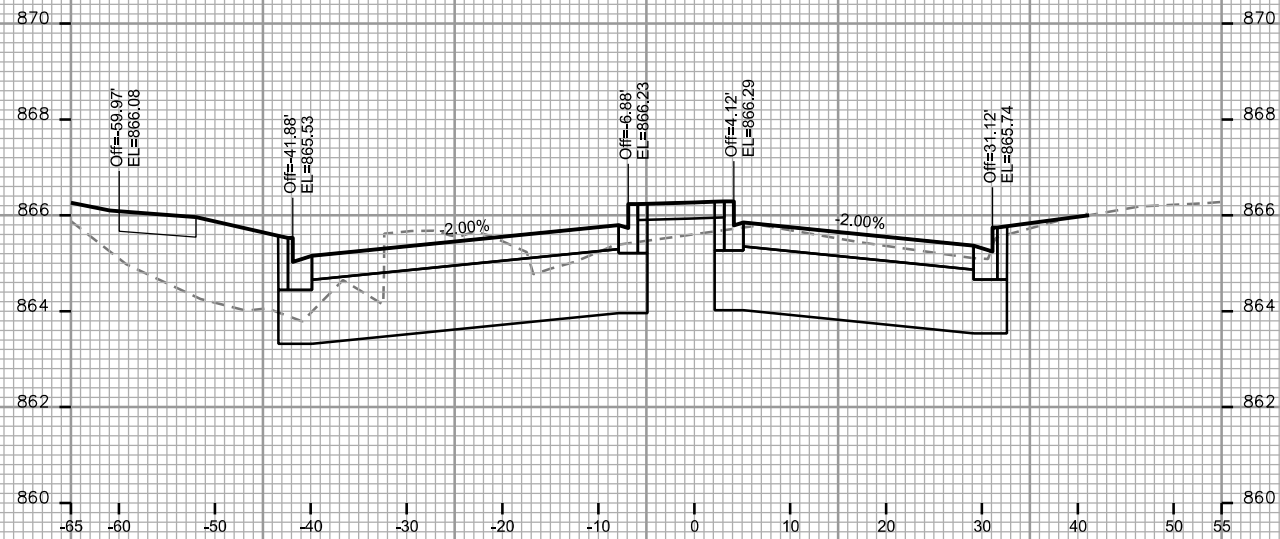
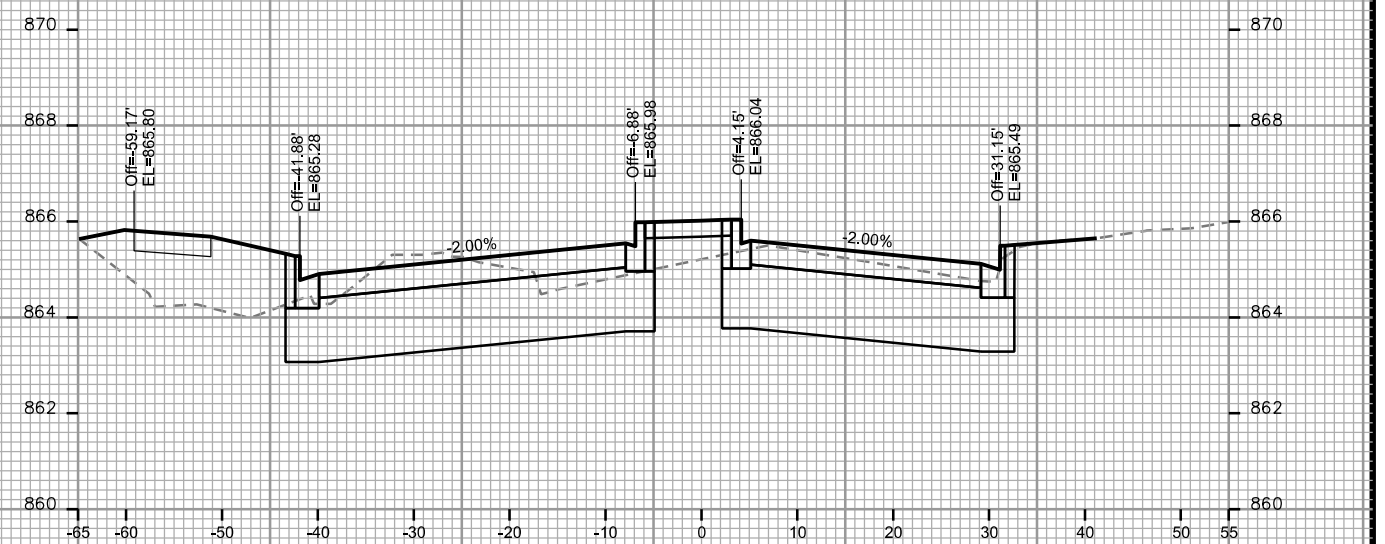
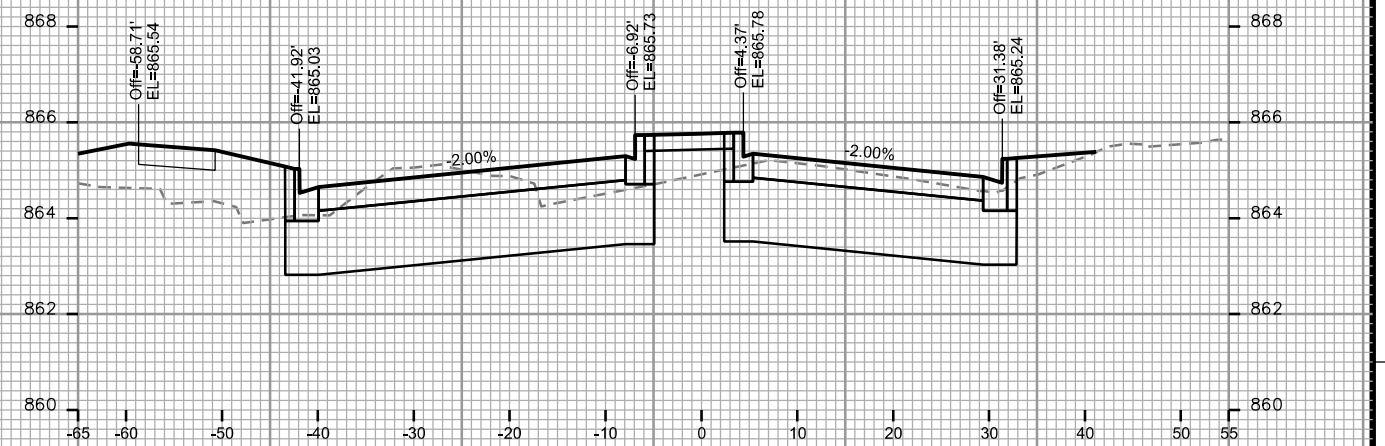
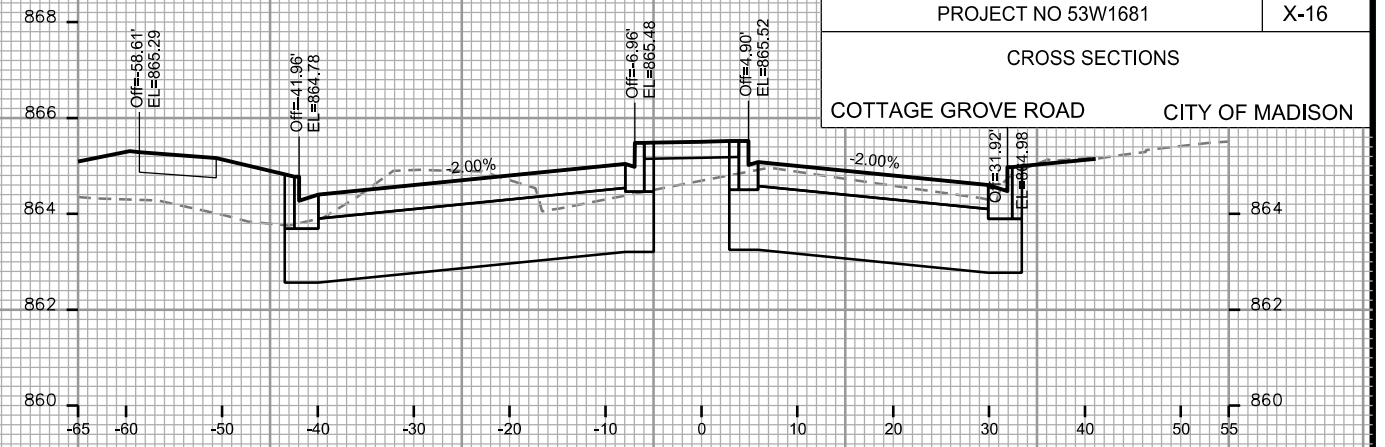

PLOT SCALE: _____

PLOT NAME: _____

REV. DATE: _____

ORIGINATOR: CITY OF MADISON - STREETS DIVISION

CROSS SECTIONS

COTTAGE GROVE ROAD

CITY OF MADISON

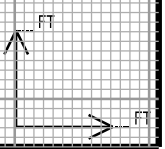
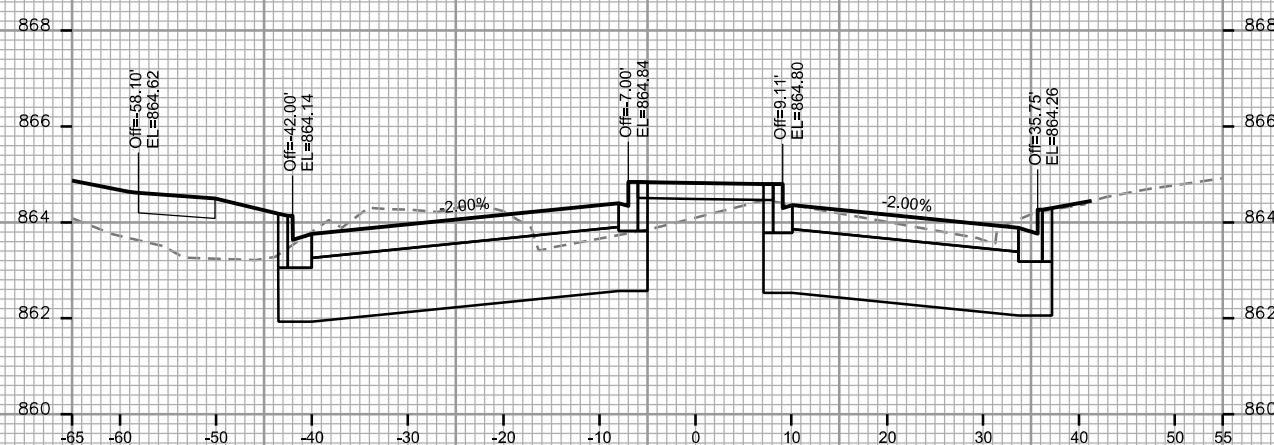
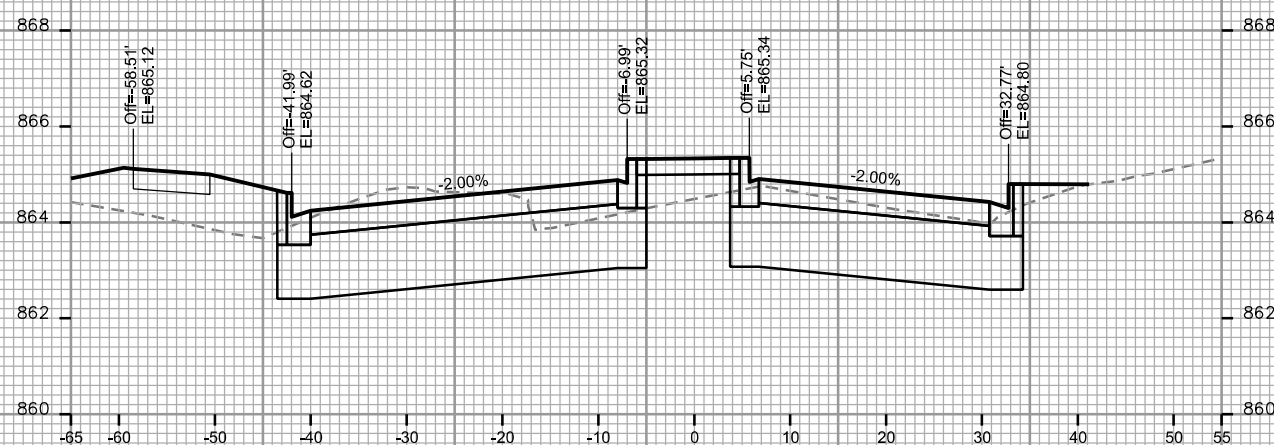
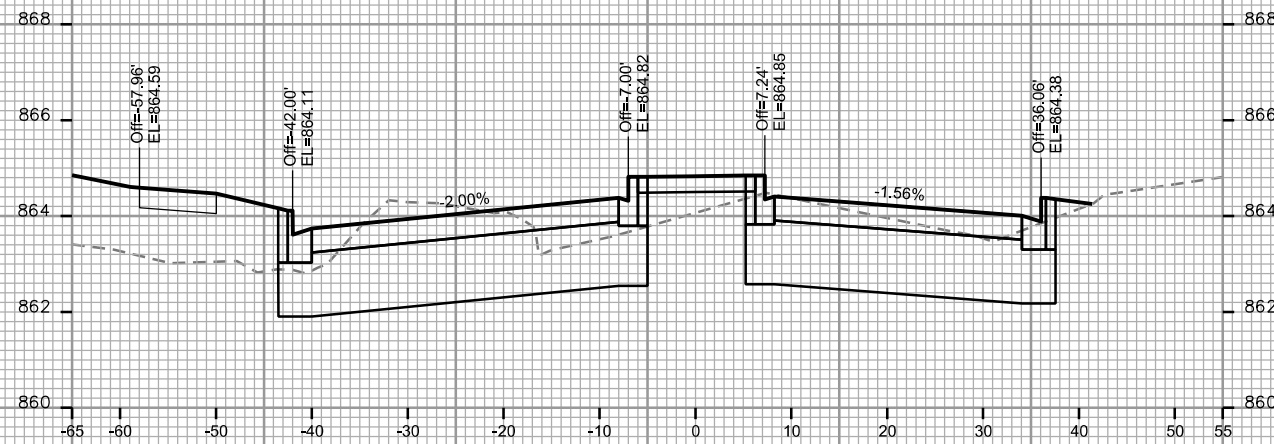
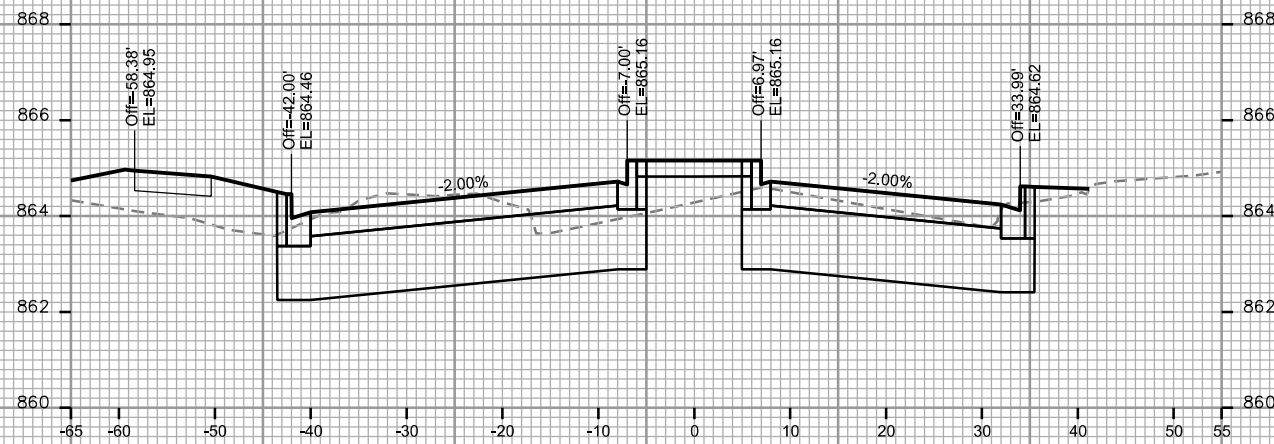
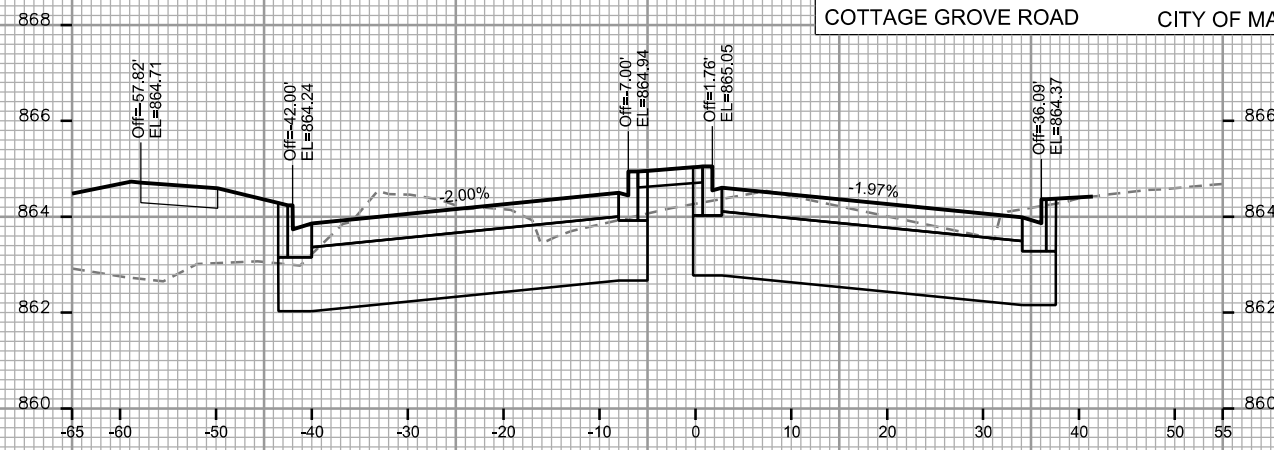
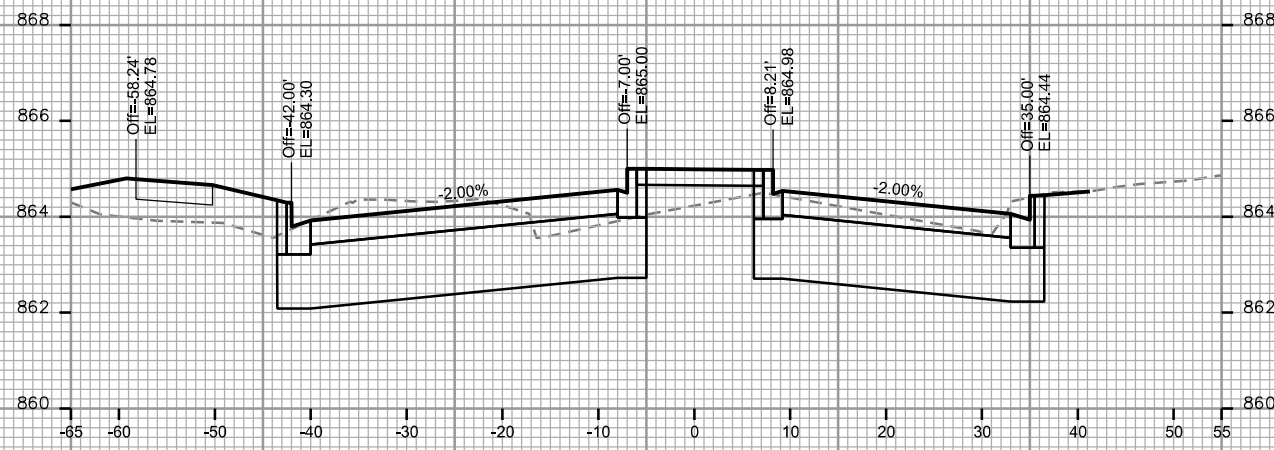

PLOT SCALE: _____

PLOT NAME: _____

REV. DATE: _____

ORIGINATOR: CITY OF MADISON - STREETS DIVISION

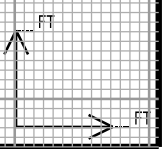
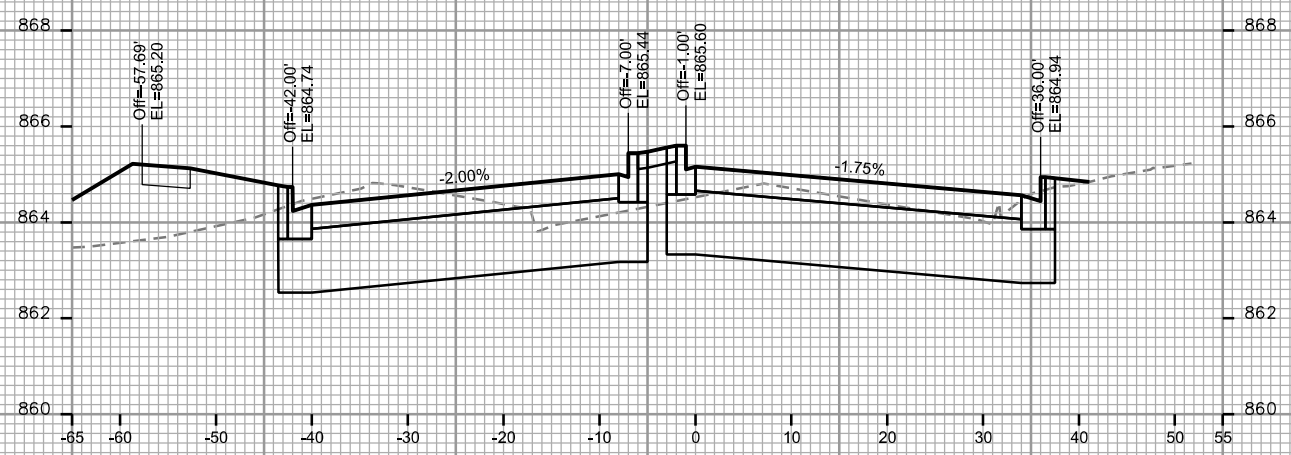
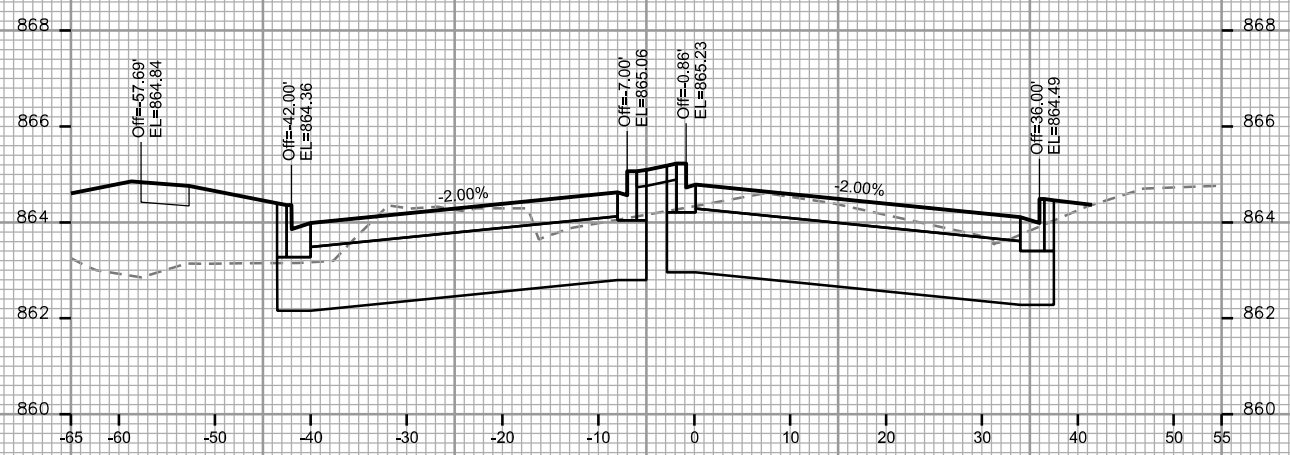
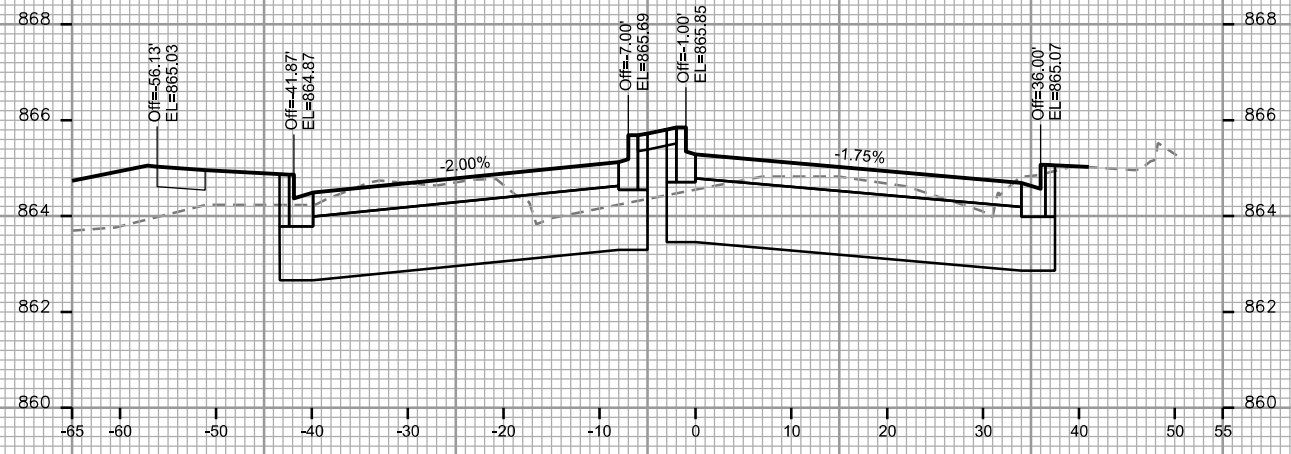
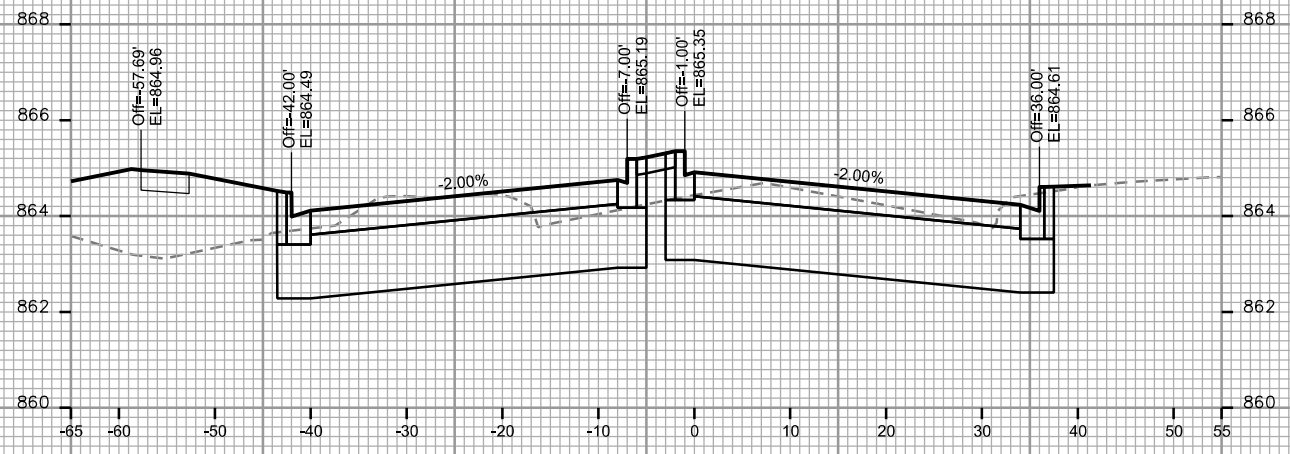
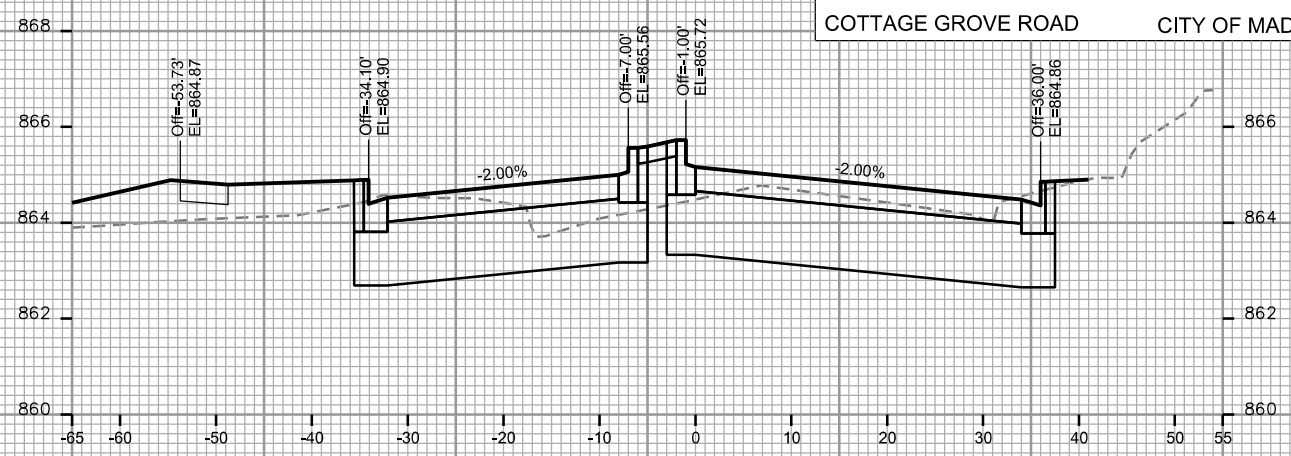
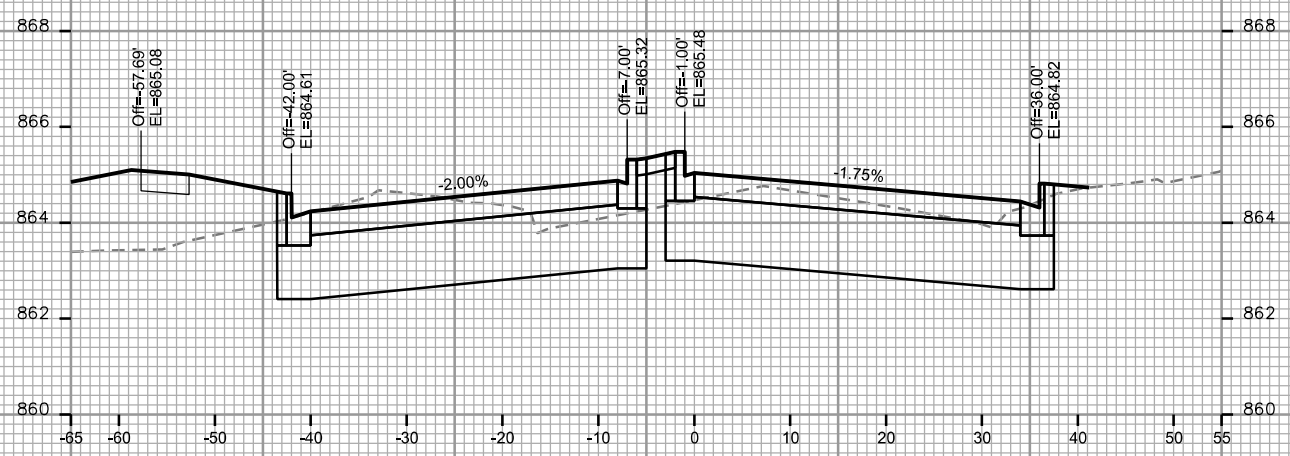

PLOT SCALE: _____

PLOT NAME: _____

REV. DATE: _____

ORIGINATOR: CITY OF MADISON - STREETS DIVISION

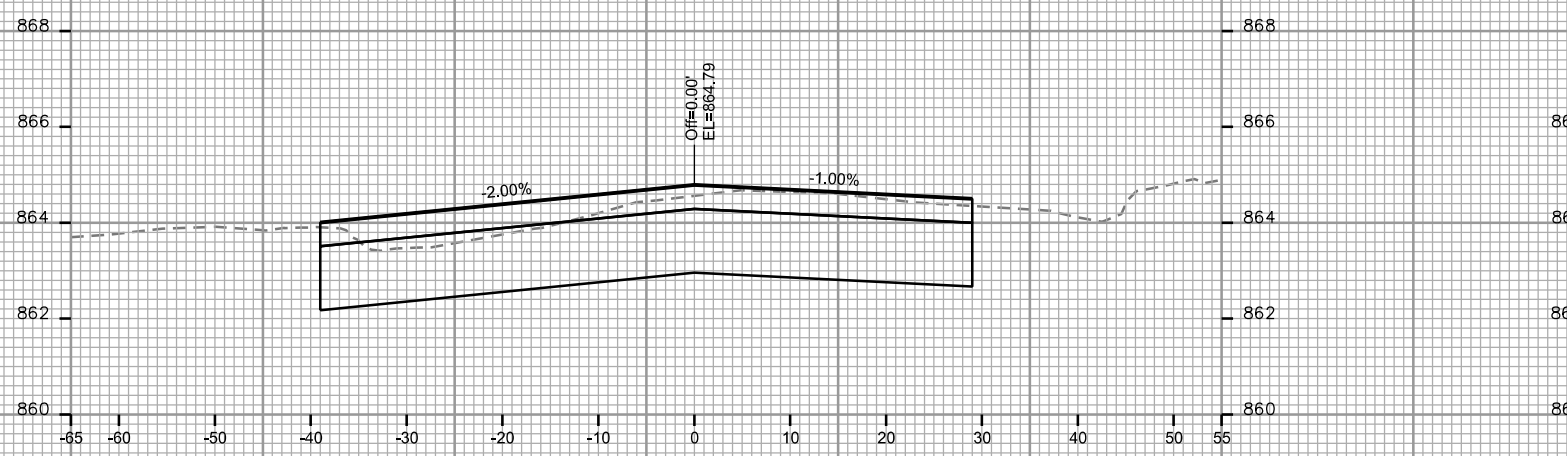

STA. 25+00

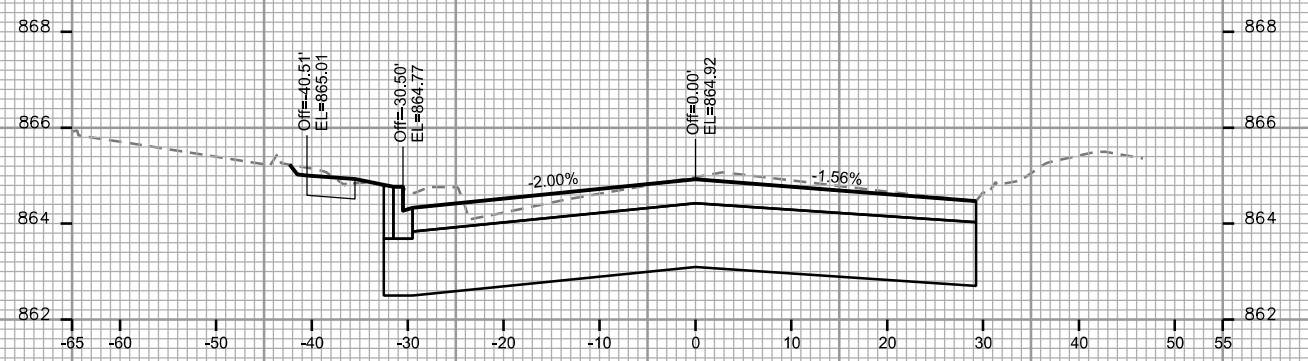

STA. 25+75

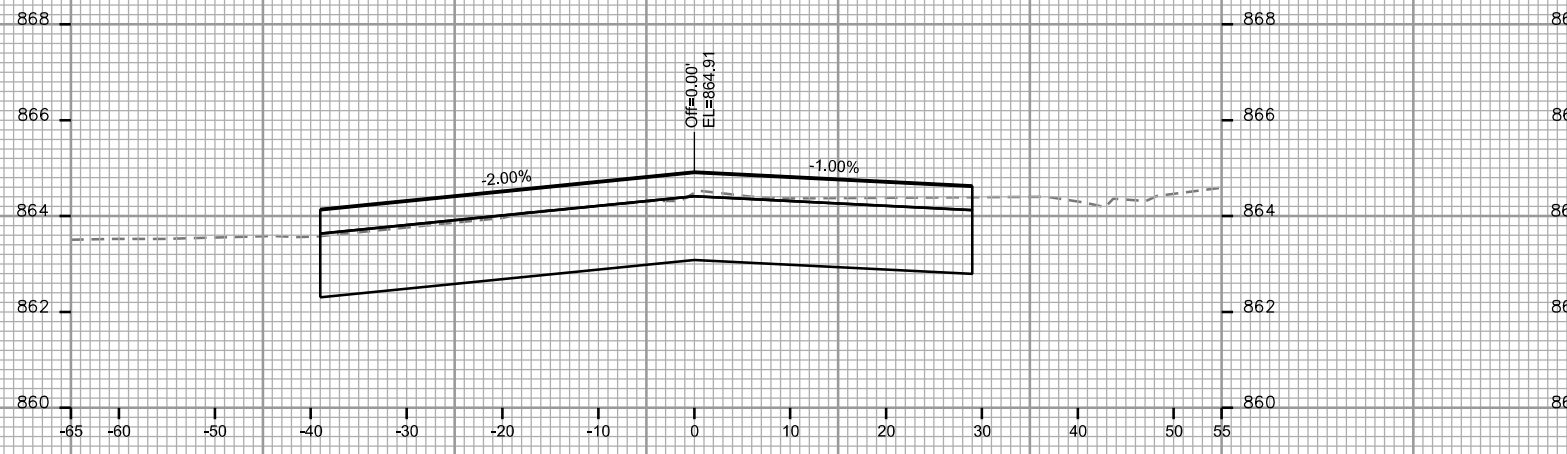

STA. 24+75

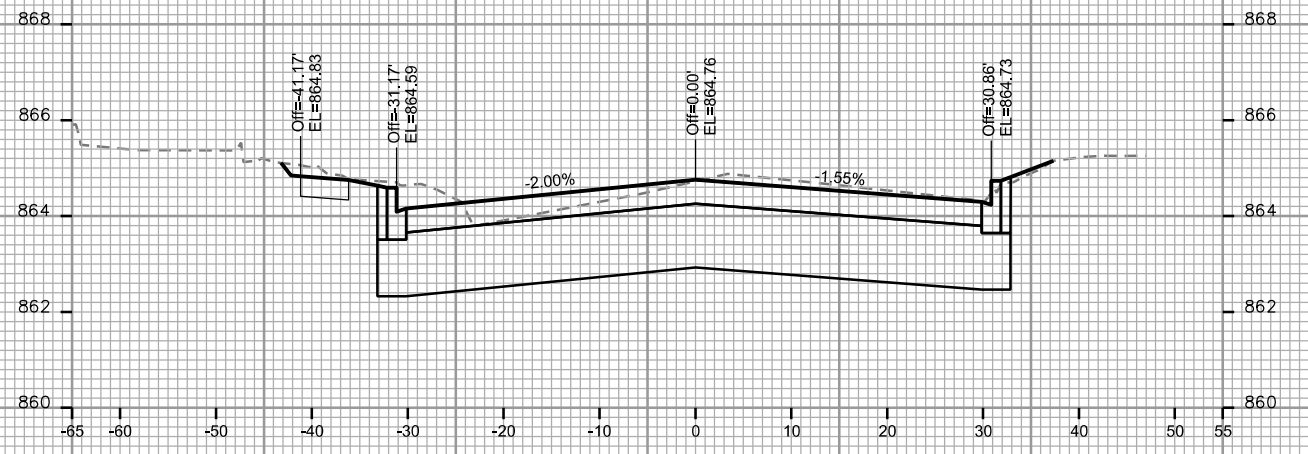

STA. 25+50

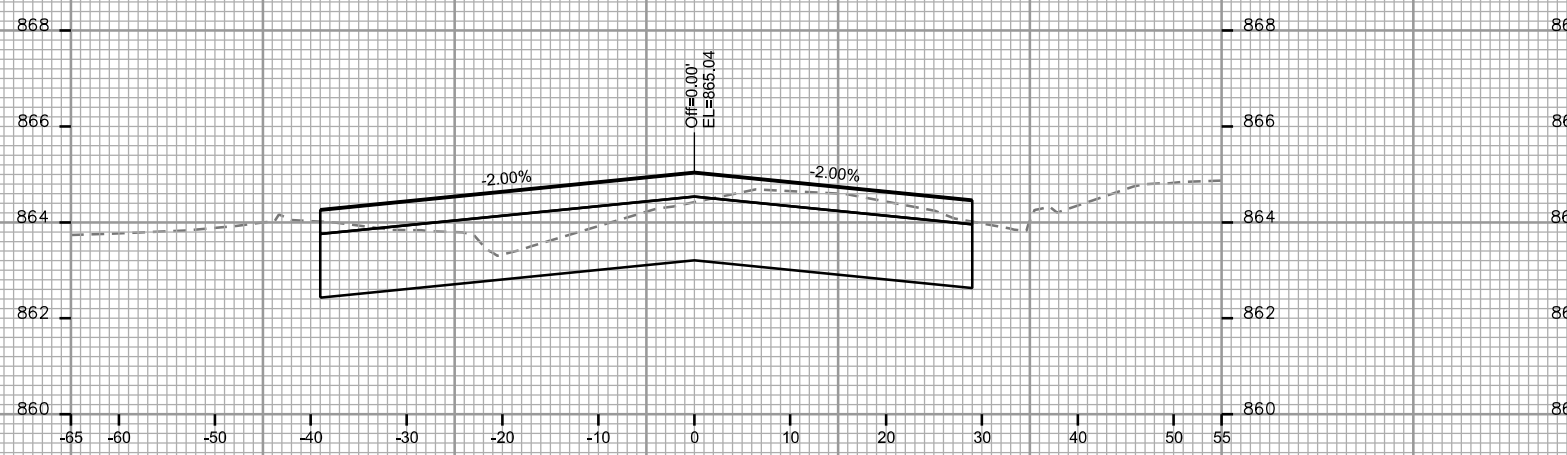

STA. 24+50

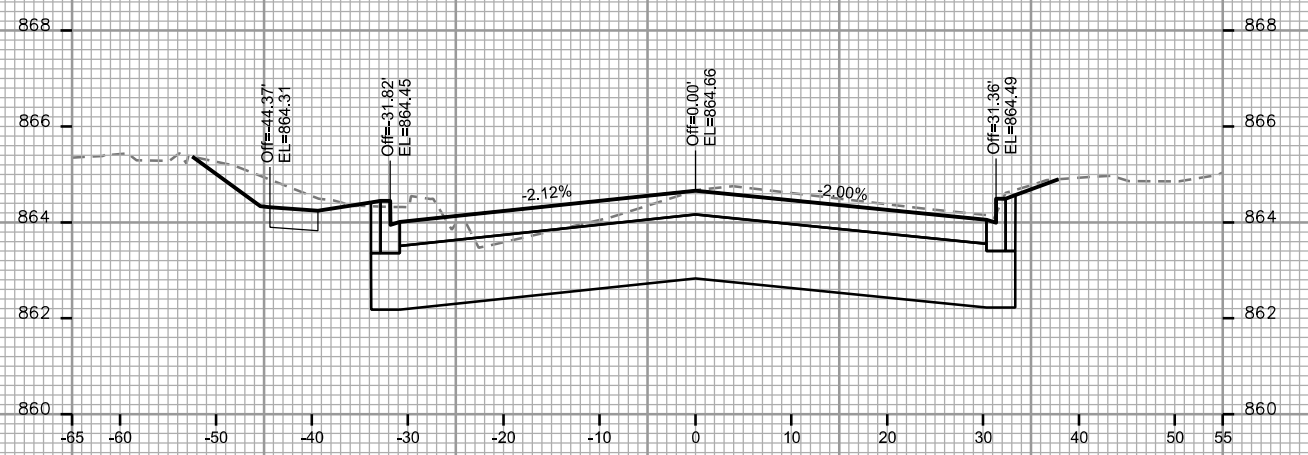

STA. 25+25

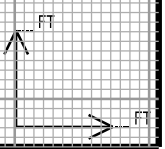

PLOT SCALE: _____

PLOT NAME: _____

REV. DATE: _____

ORIGINATOR: CITY OF MADISON - STREETS DIVISION

PLOT SCALE: _____

PLOT NAME: _____

REV. DATE: _____

ORIGINATOR: CITY OF MADISON, STREETS DIVISION

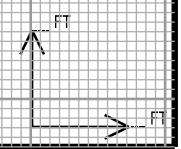
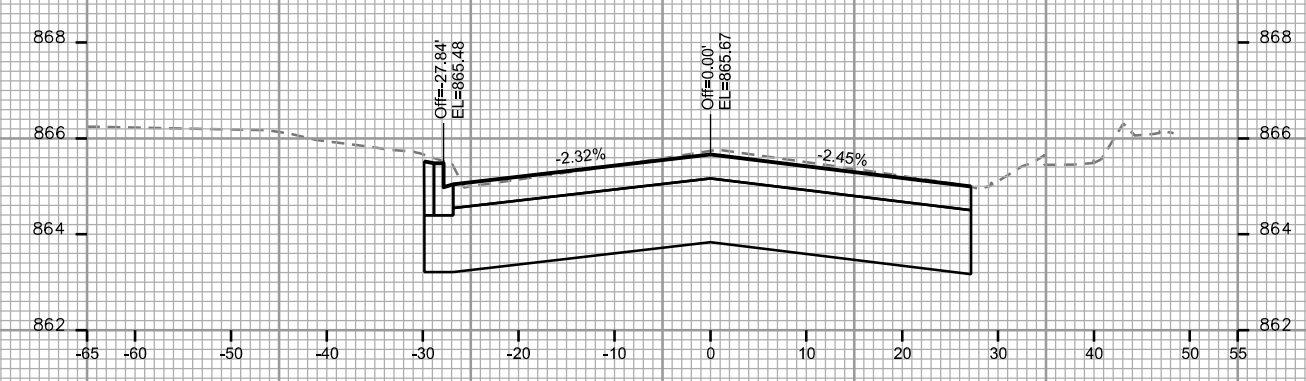
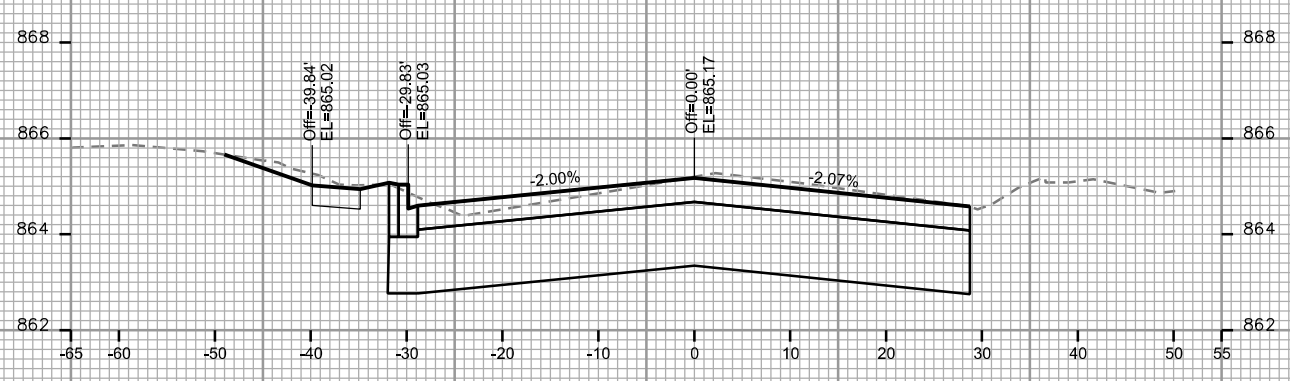
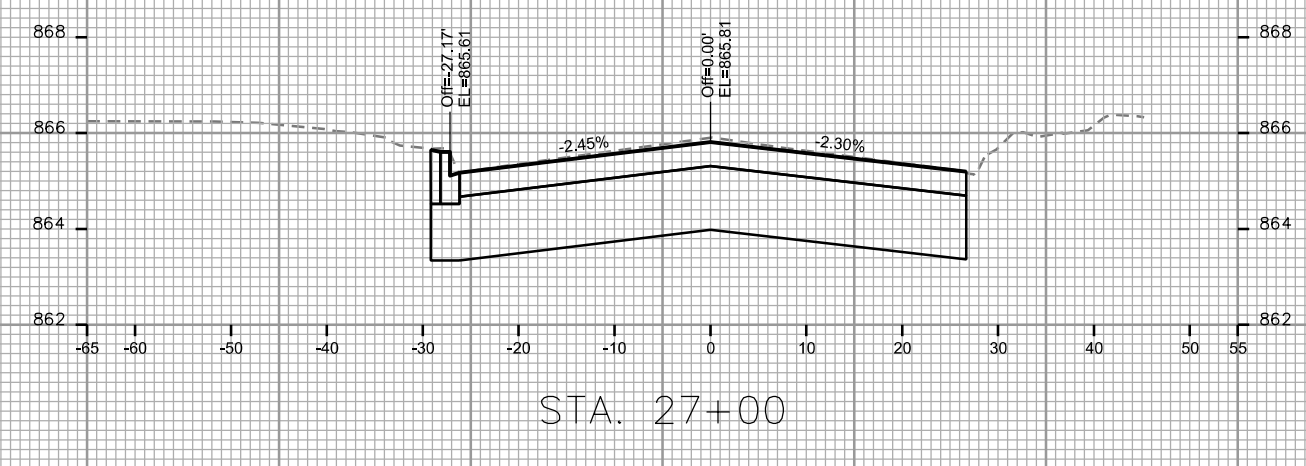
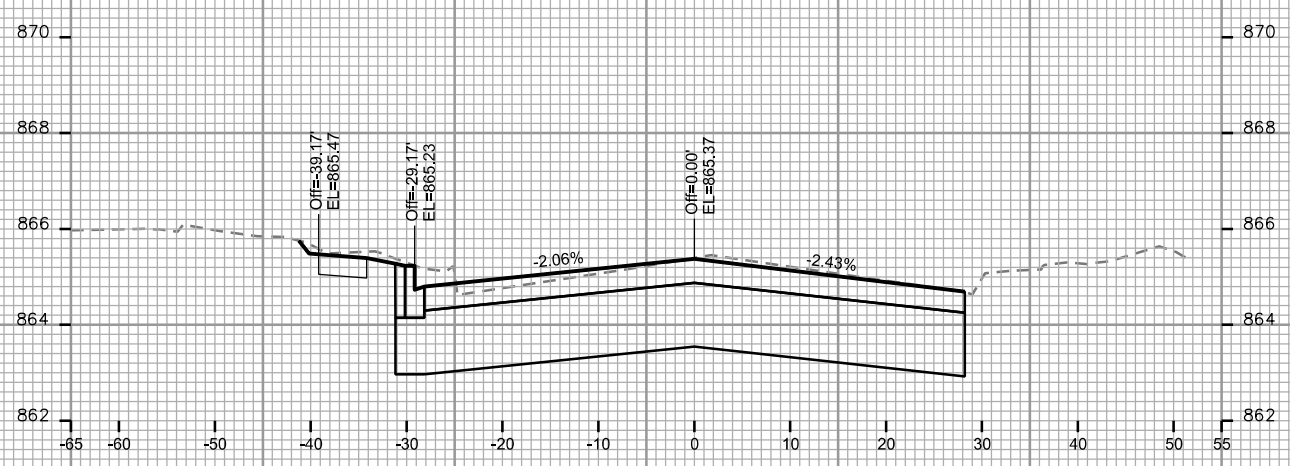
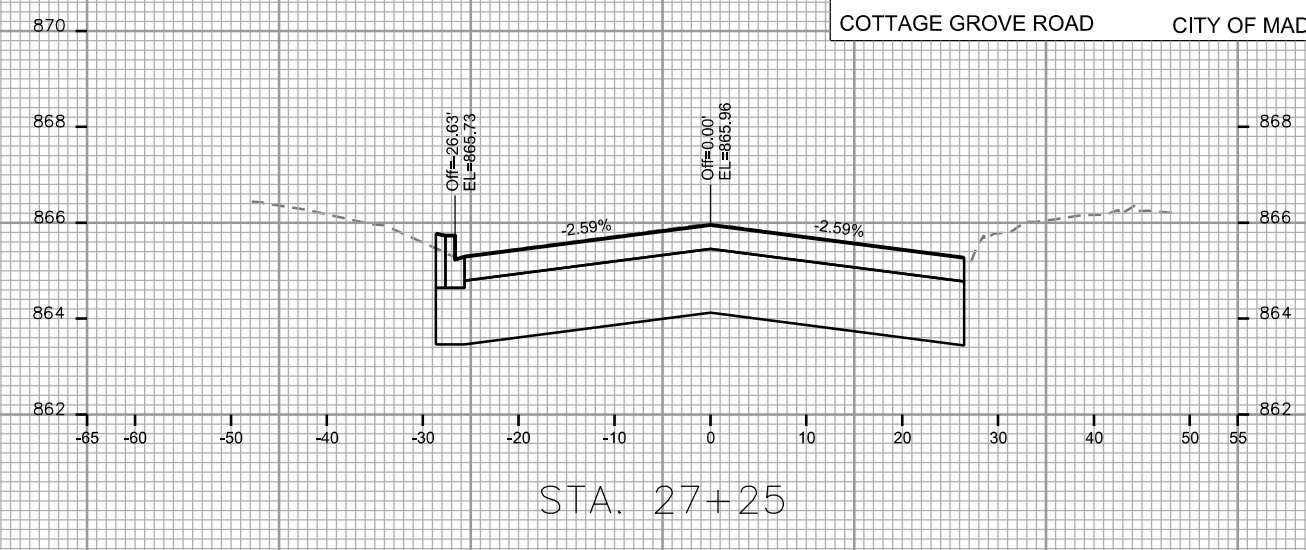
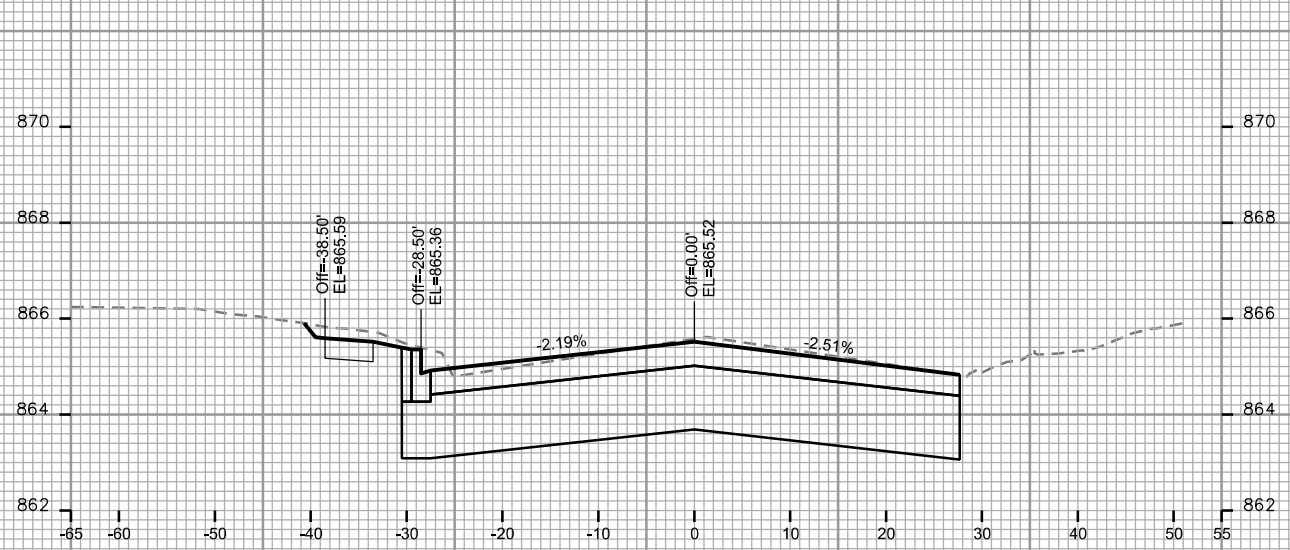

PLOT SCALE: _____

PLOT NAME: _____

REV. DATE: _____

ORIGINATOR: CITY OF MADISON, STREETS DIVISION

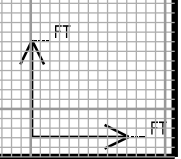
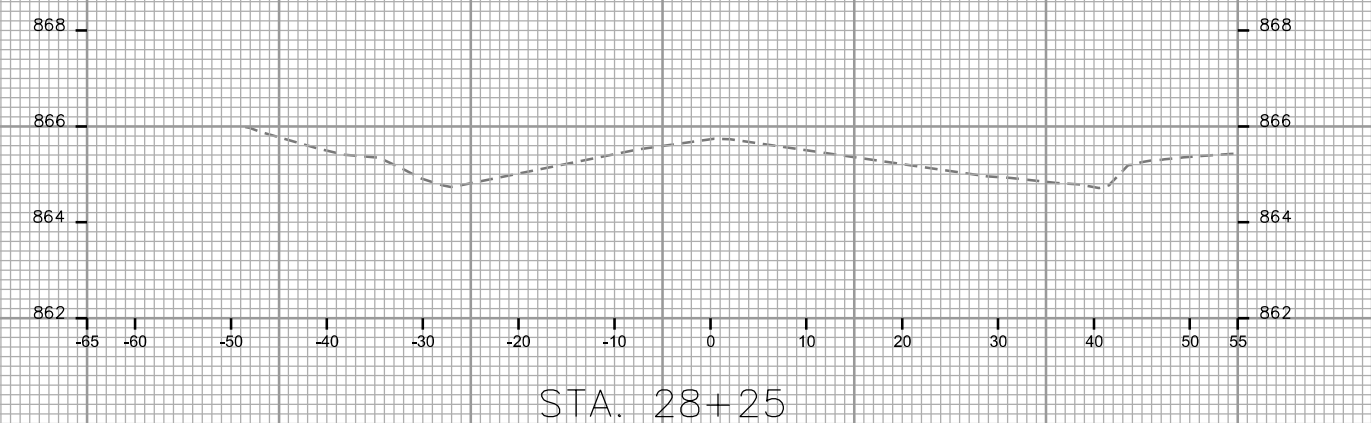
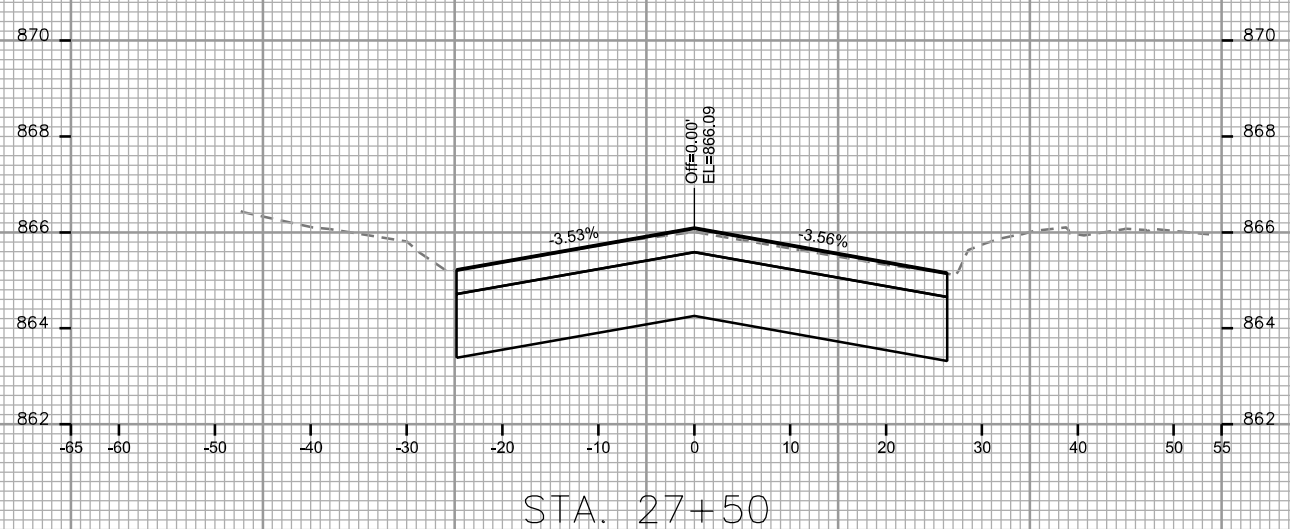
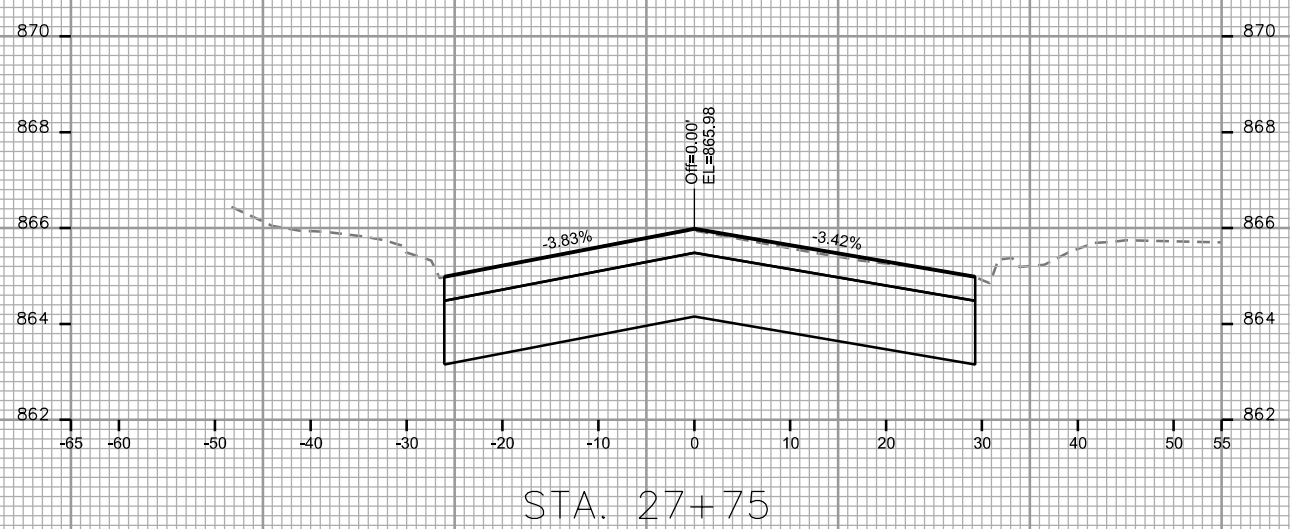
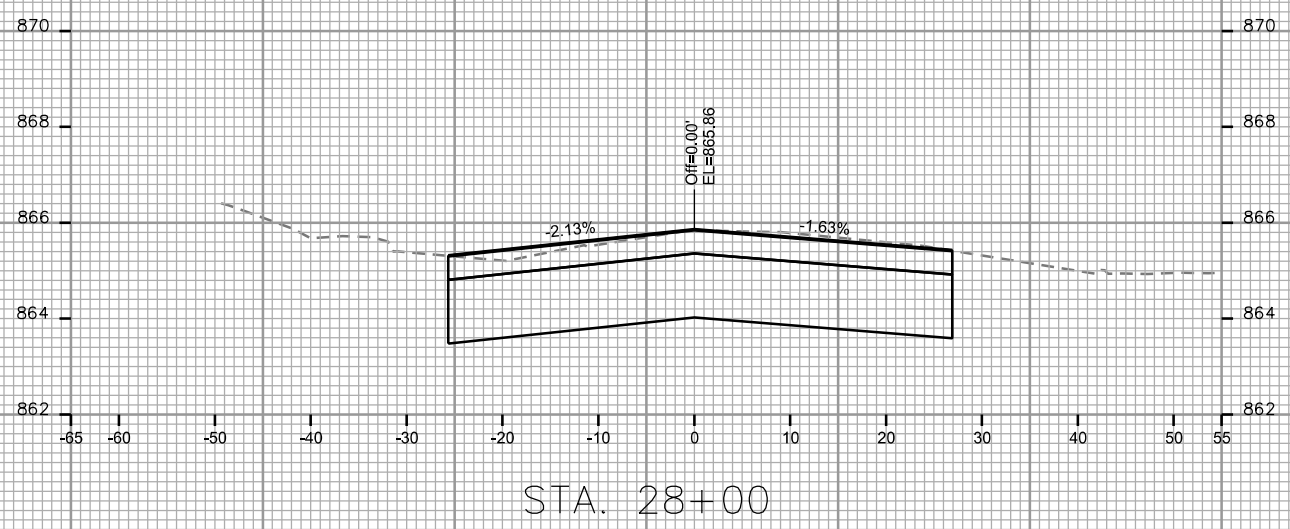

CROSS SECTIONS
DEMPSEY ROAD CITY OF MADISON

PLOT SCALE: _____

PLOT NAME: _____

REV. DATE: _____

ORIGINATOR: CITY OF MADISON - STREETS DIVISION

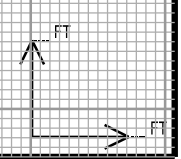
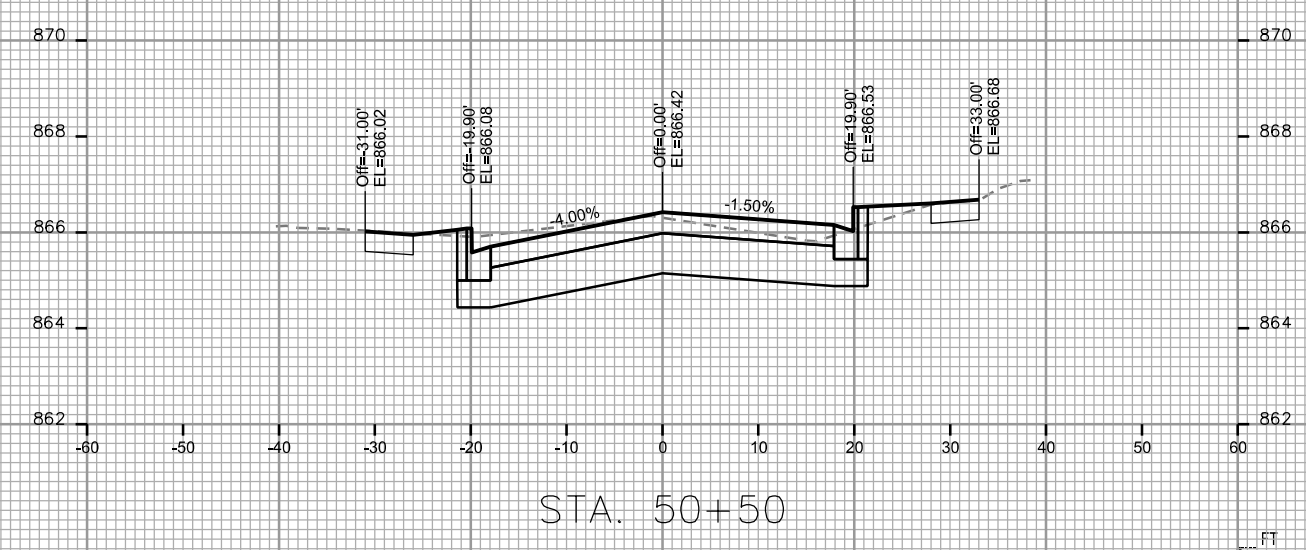
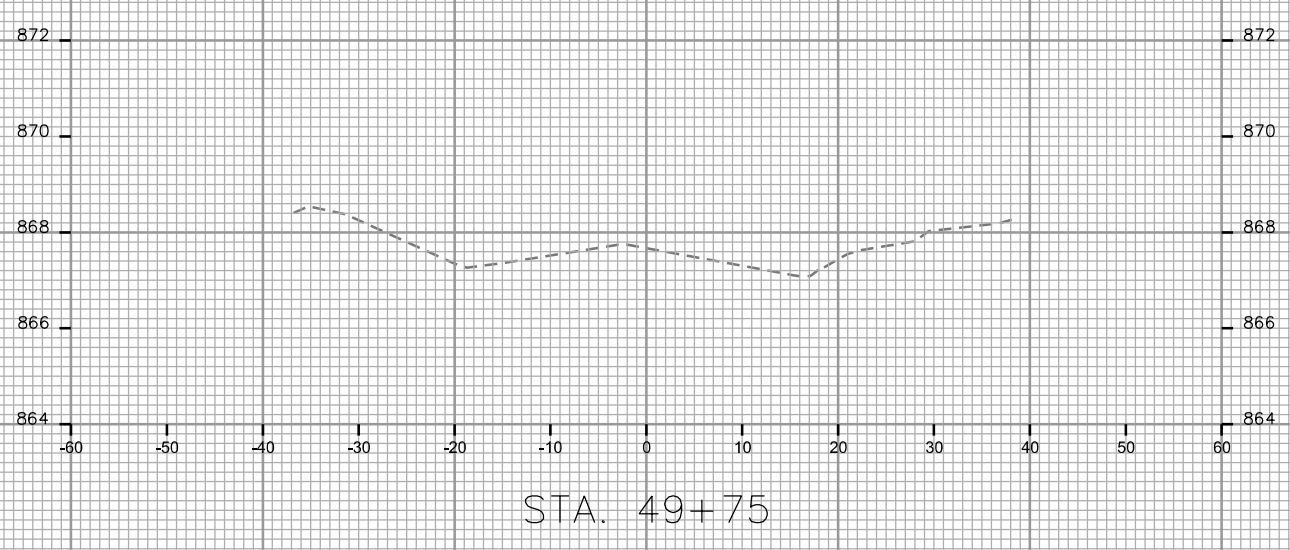
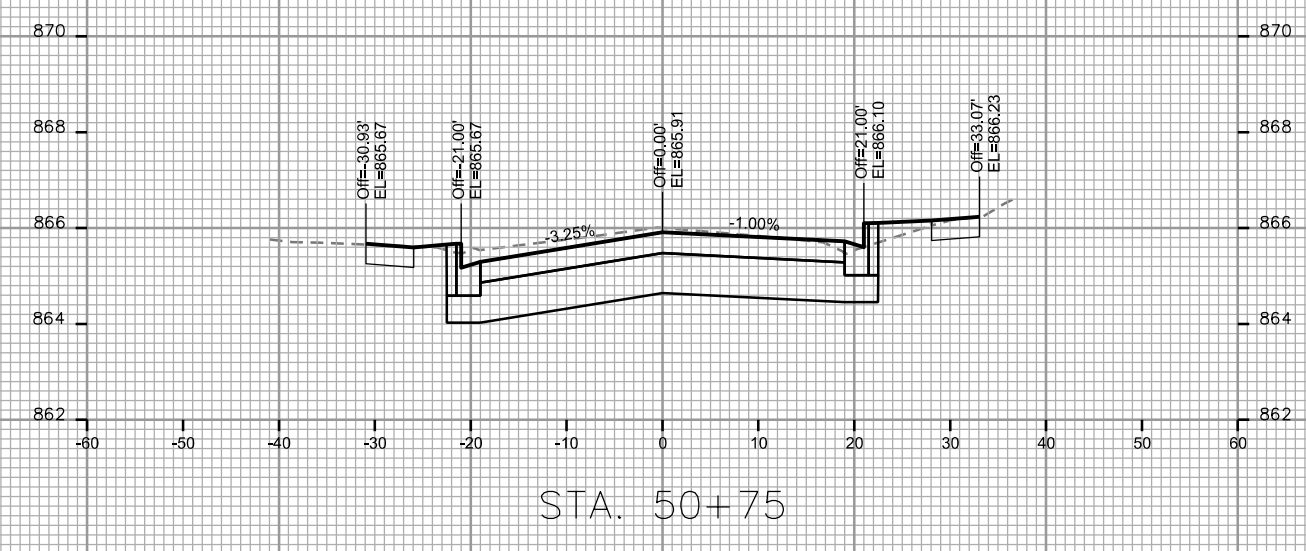
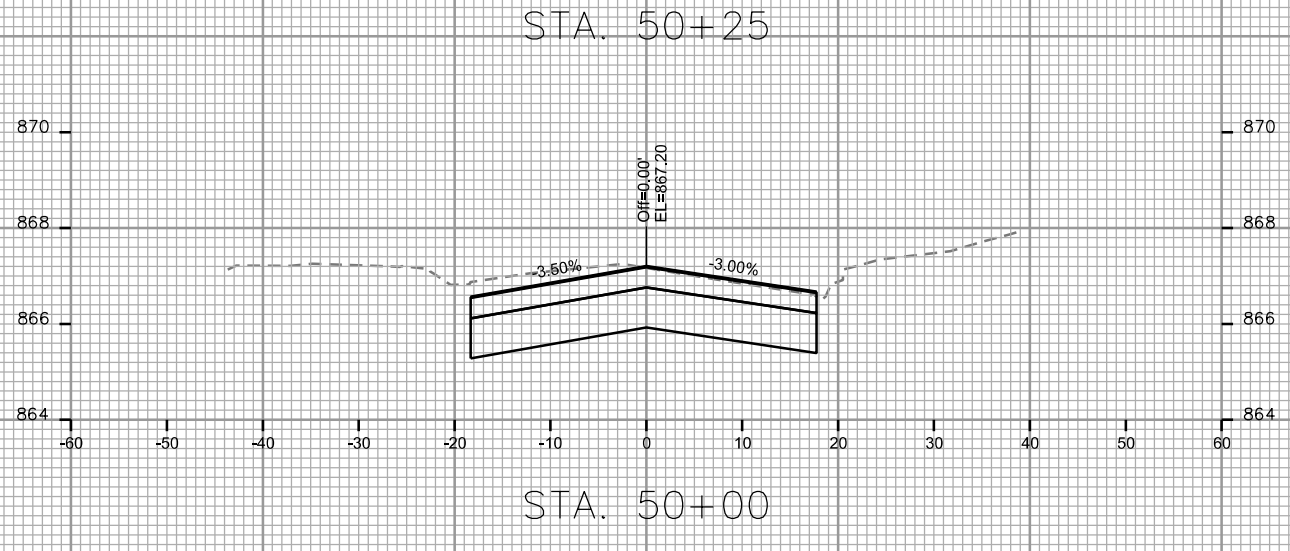
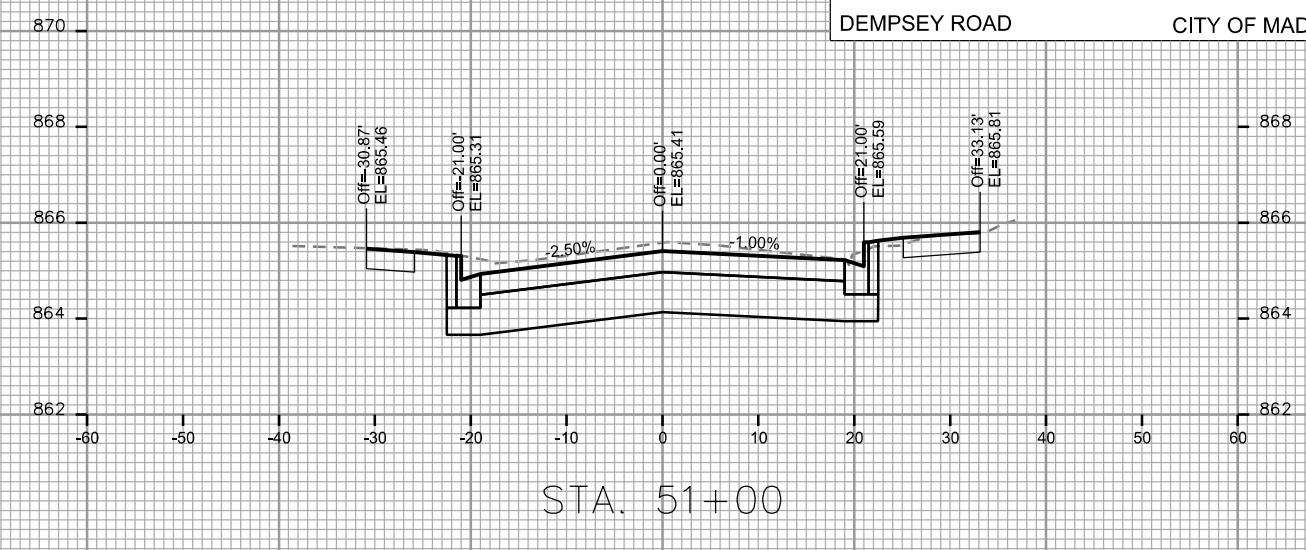
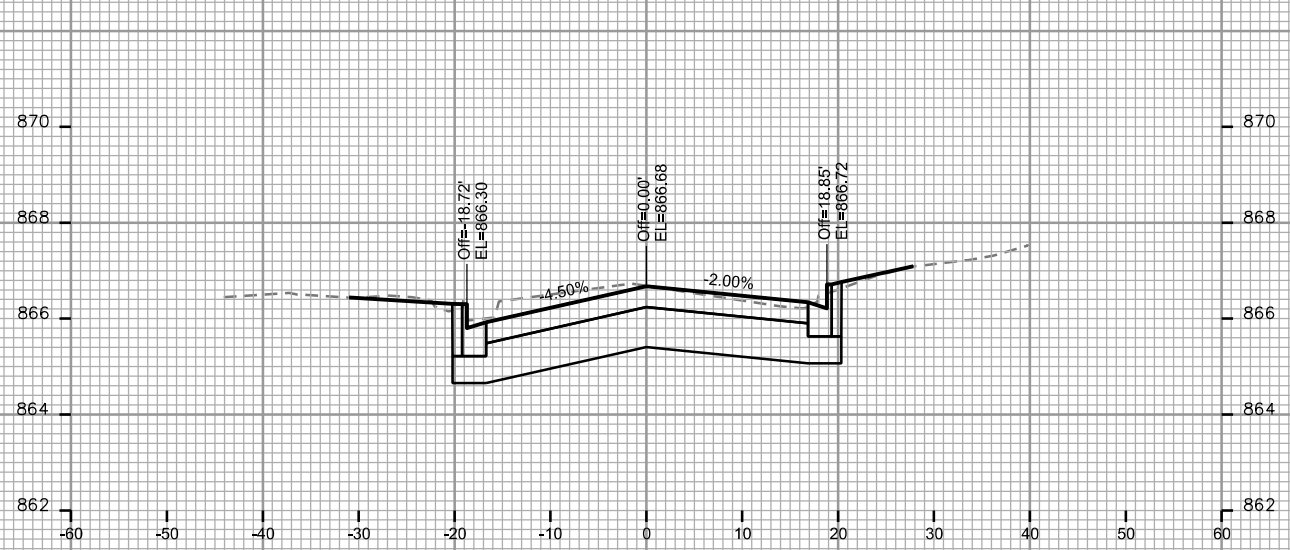

PLOT SCALE: _____

PLOT NAME: _____

REV. DATE: _____

ORIGINATOR: CITY OF MADISON, STREETS DIVISION

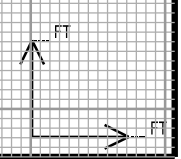
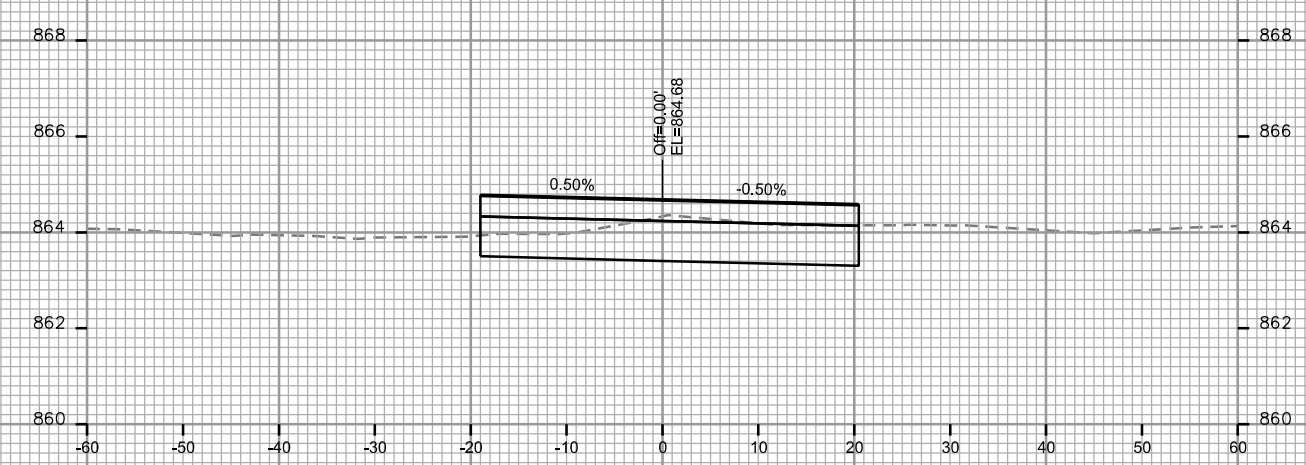
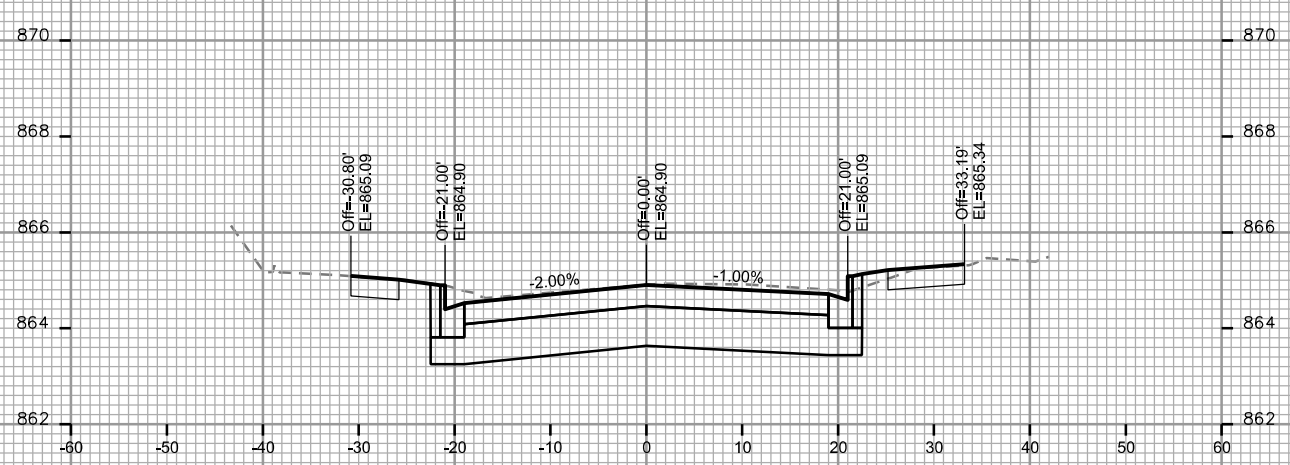
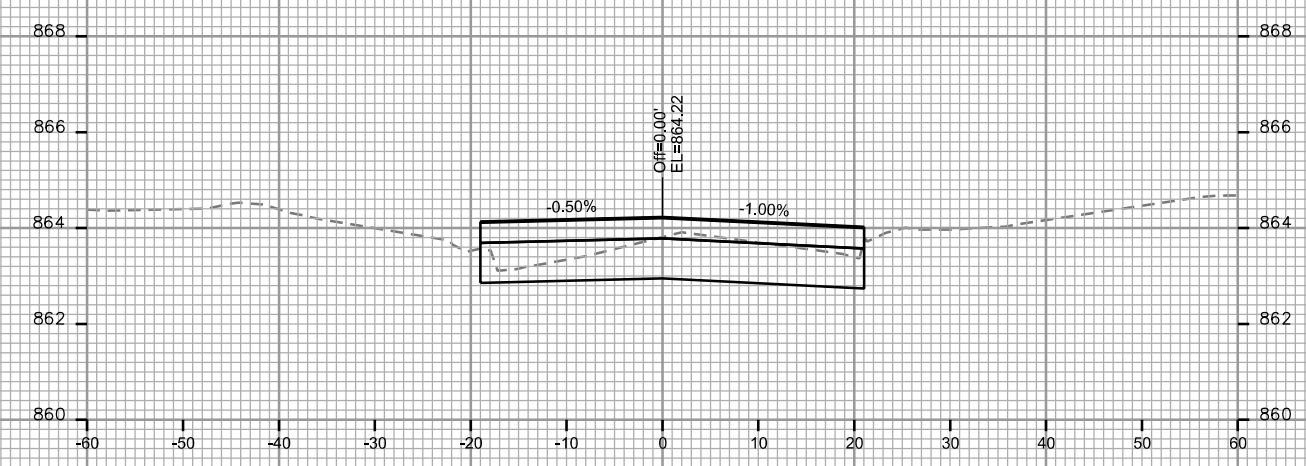
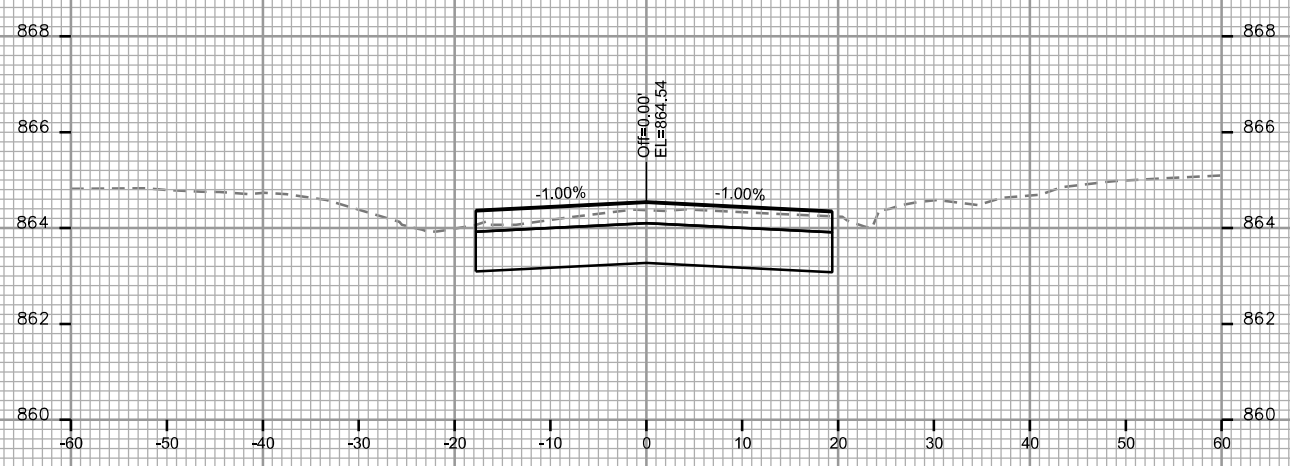
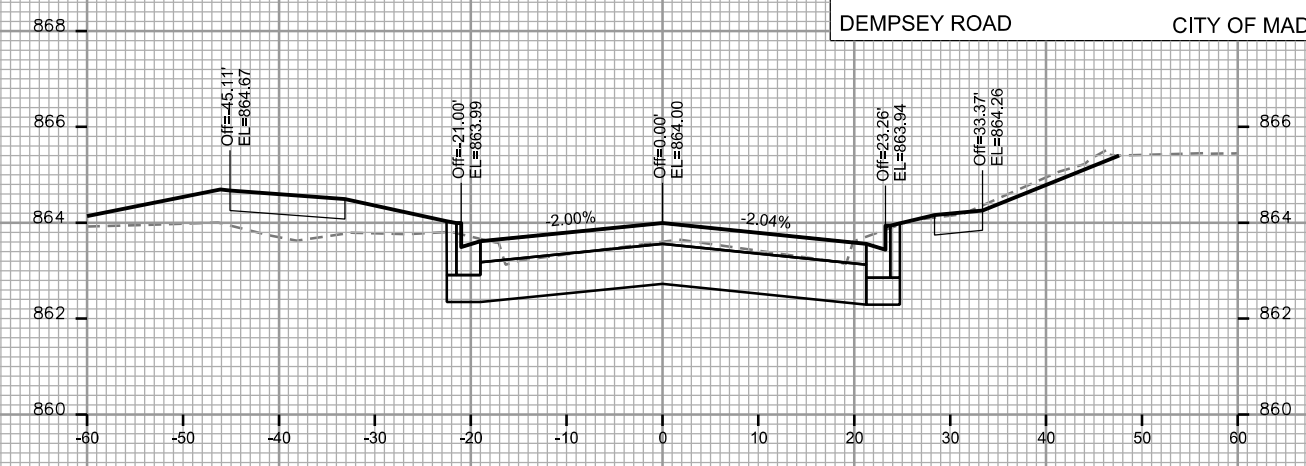
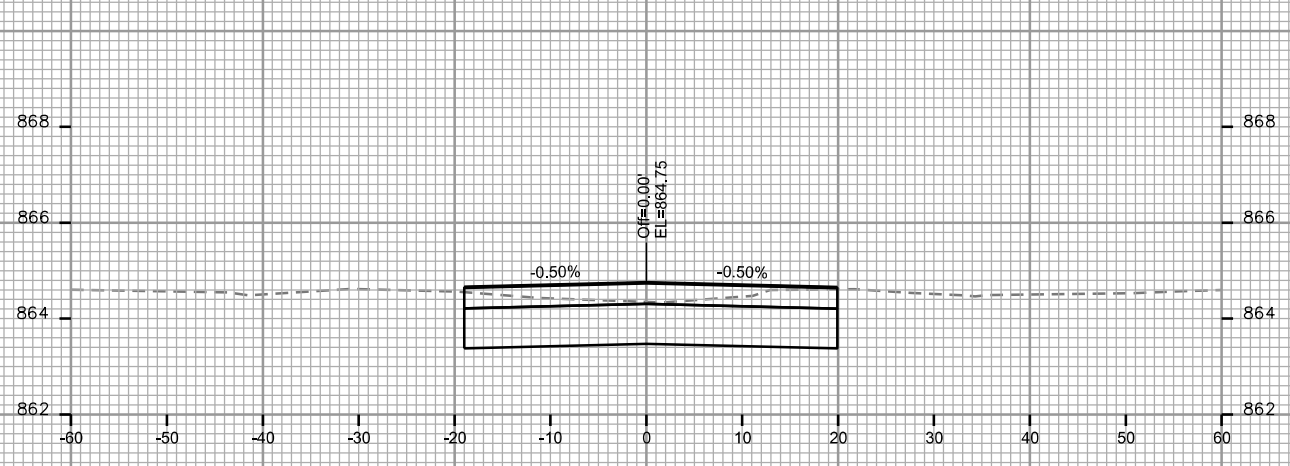

PLOT SCALE: _____

PLOT NAME: _____

REV. DATE: _____

ORIGINATOR: CITY OF MADISON, STREETS DIVISION

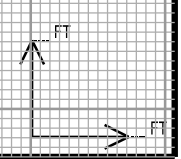
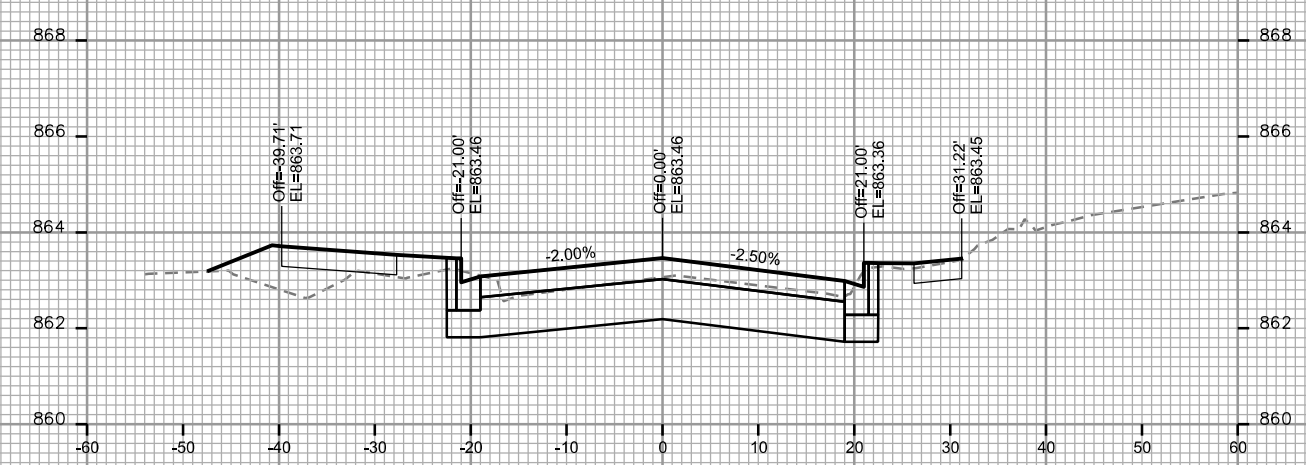
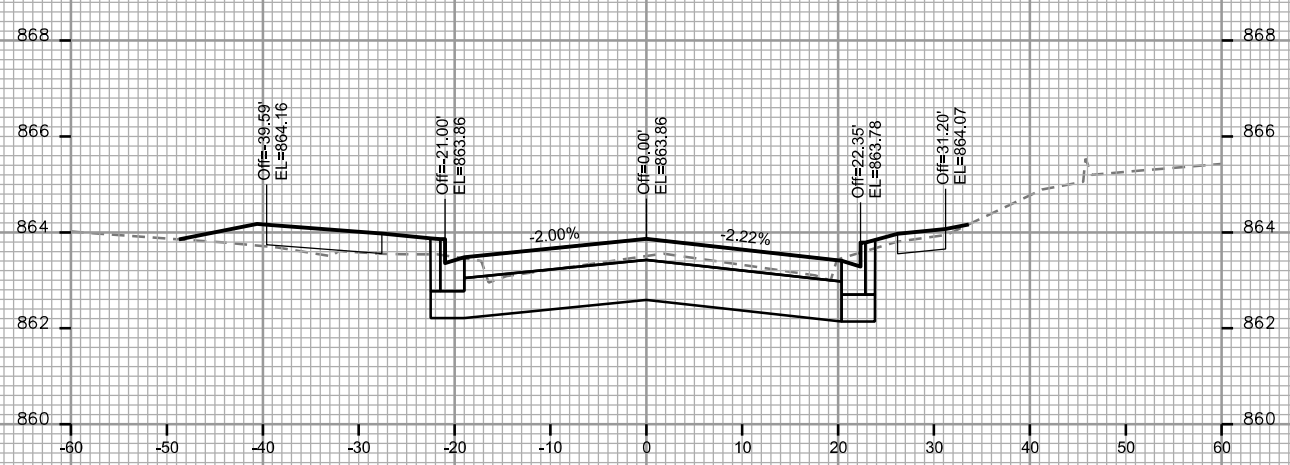
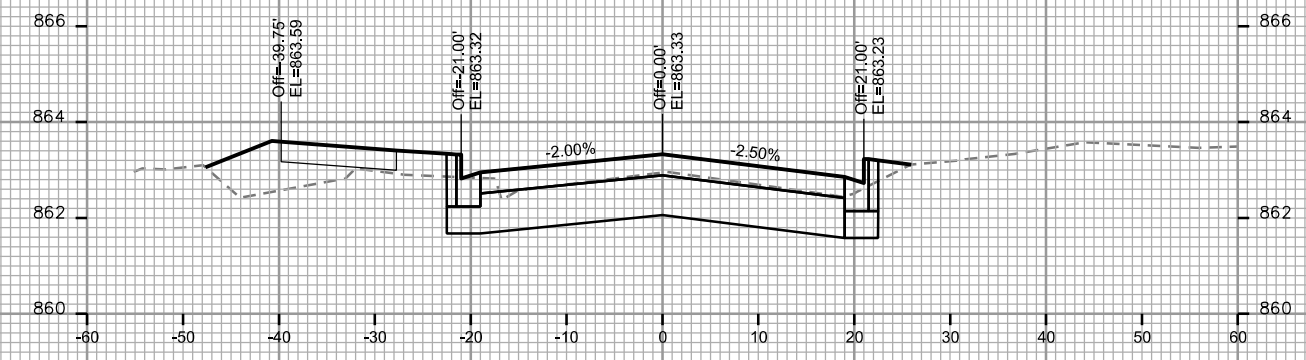
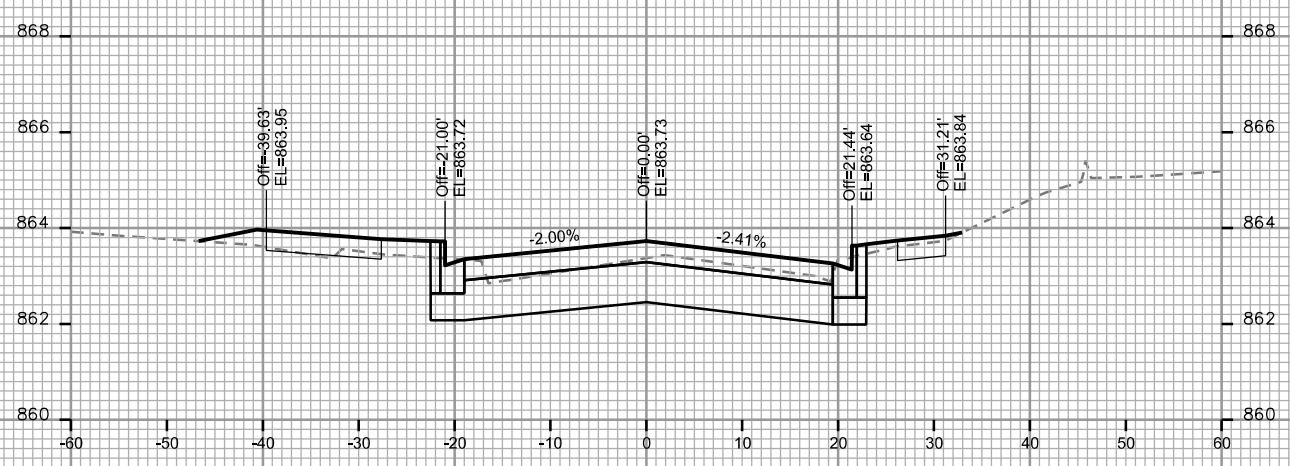
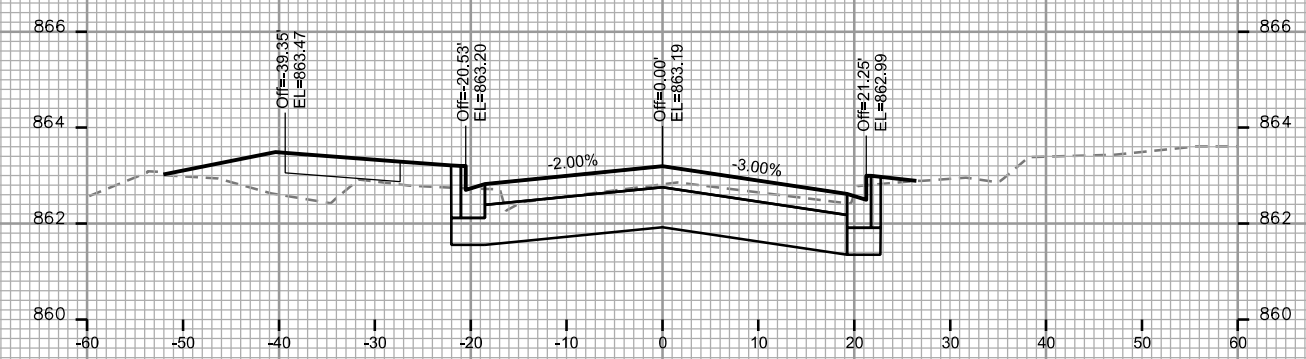
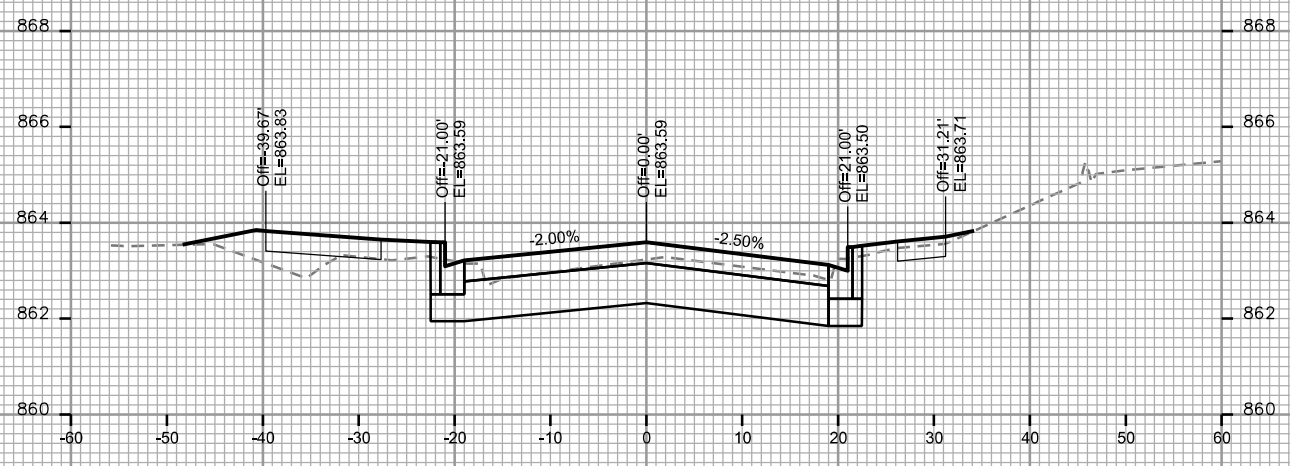

CROSS SECTIONS
DEMPSEY ROAD CITY OF MADISON

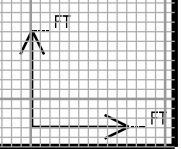
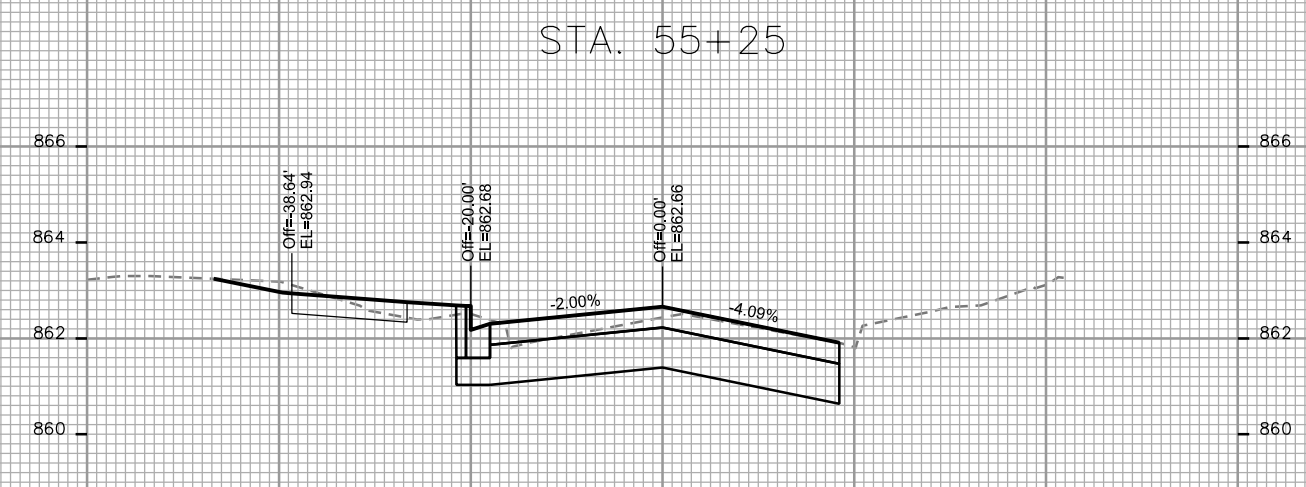
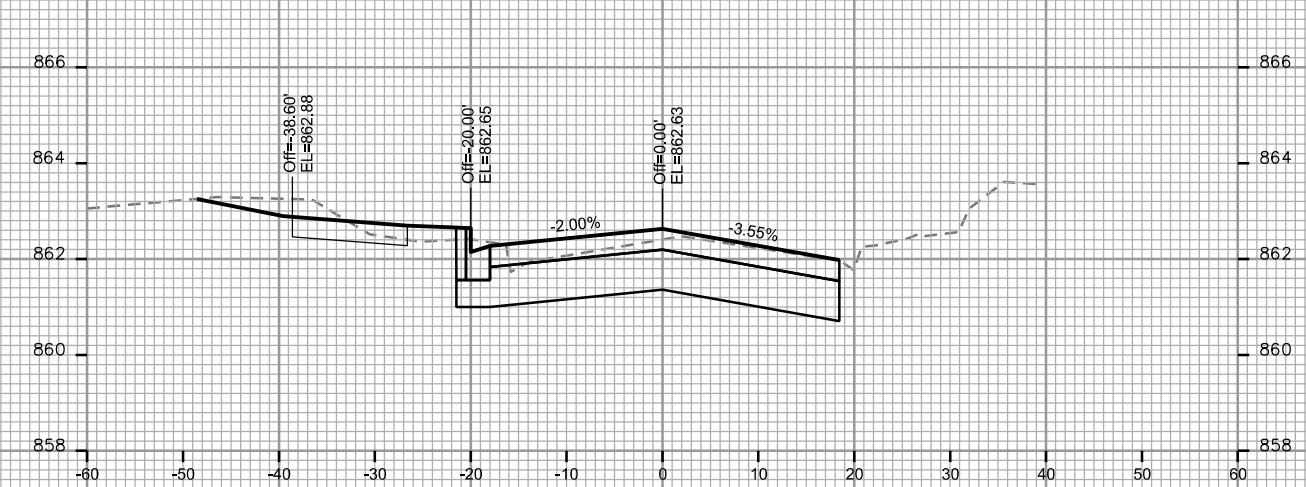
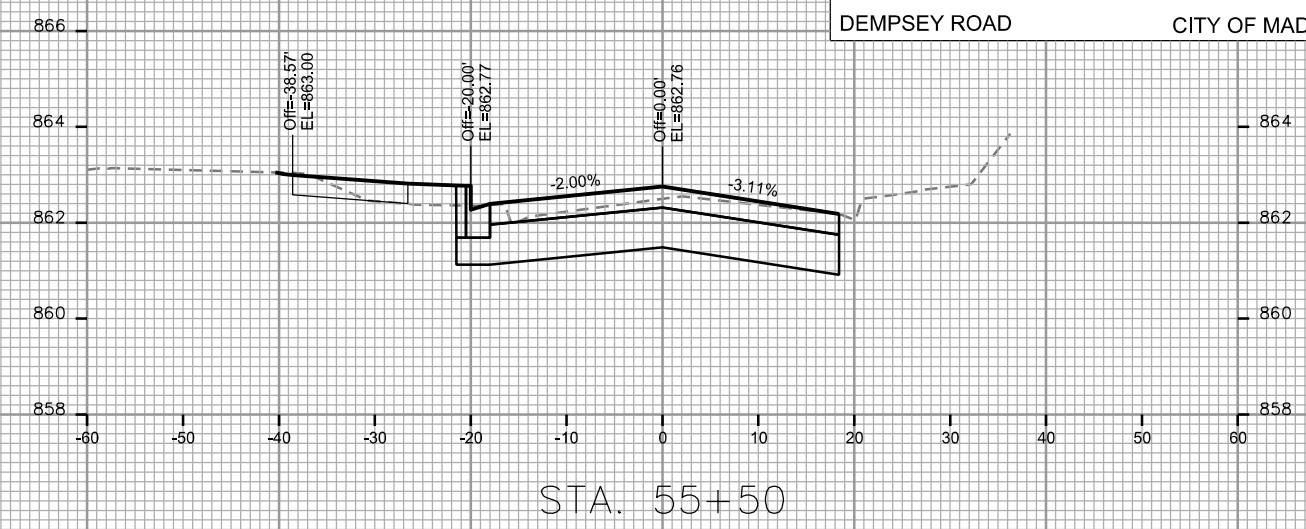
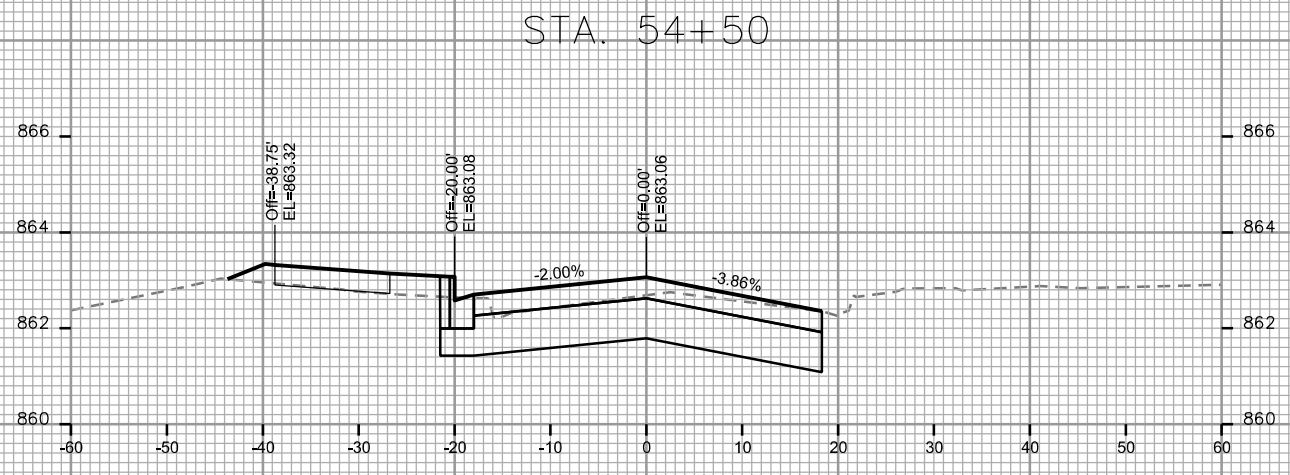
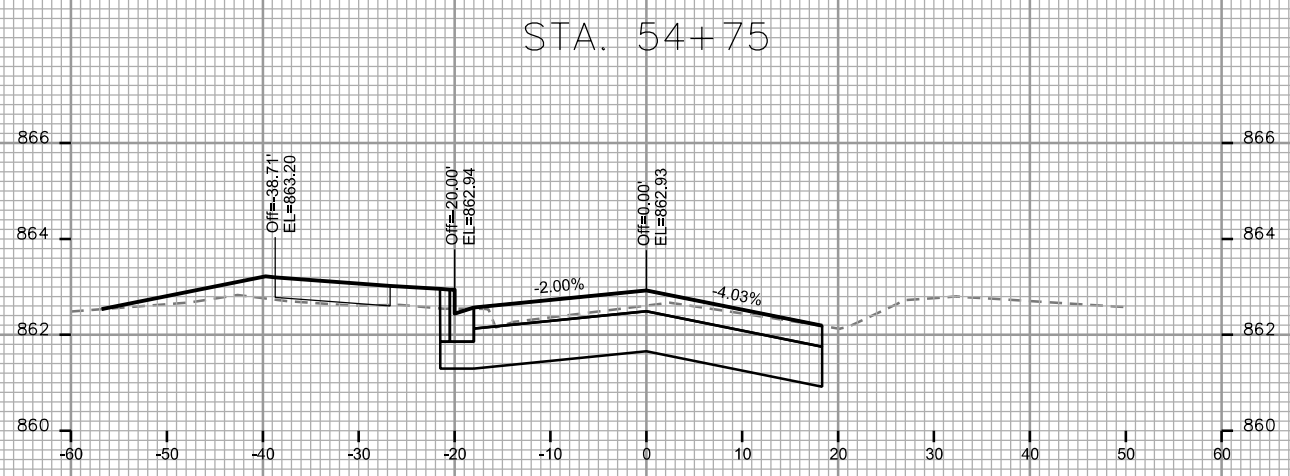
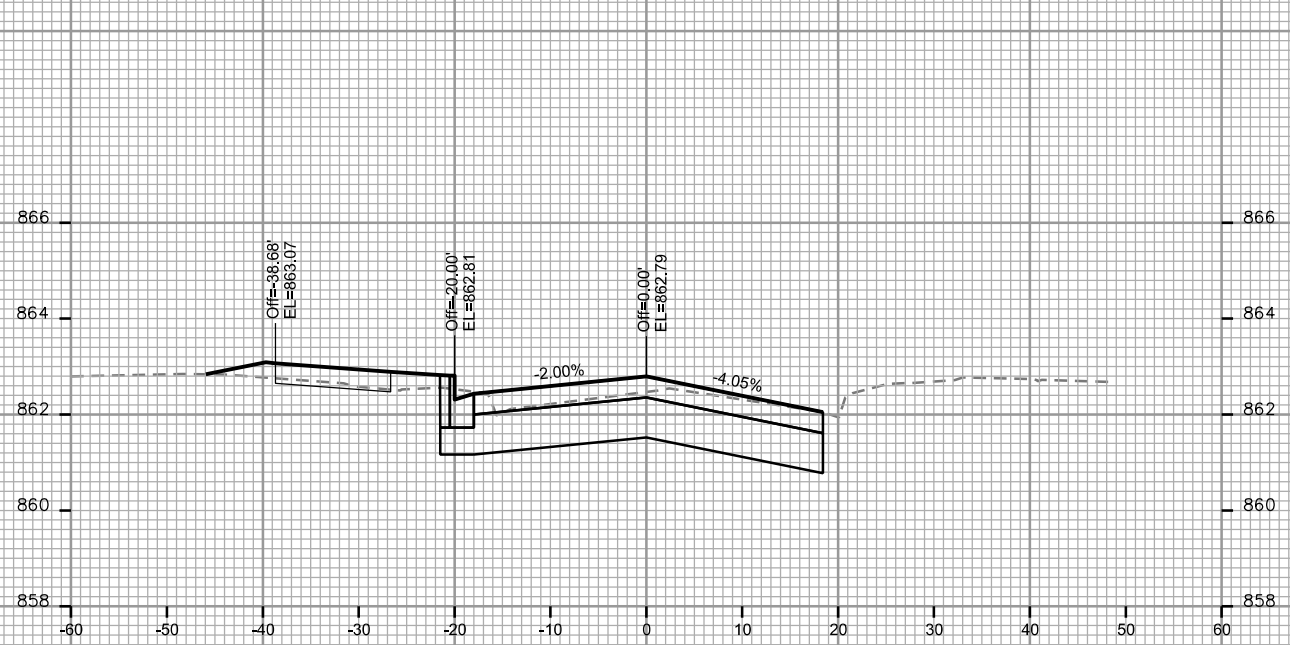

PLOT SCALE: _____

PLOT NAME: _____

REV. DATE: _____

ORIGINATOR: CITY OF MADISON - STREETS DIVISION

CROSS SECTIONS
DEMPSEY ROAD CITY OF MADISON

PLOT SCALE: _____

PLOT NAME: _____

REV. DATE: _____

ORIGINATOR: CITY OF MADISON - STREETS DIVISION

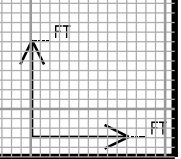
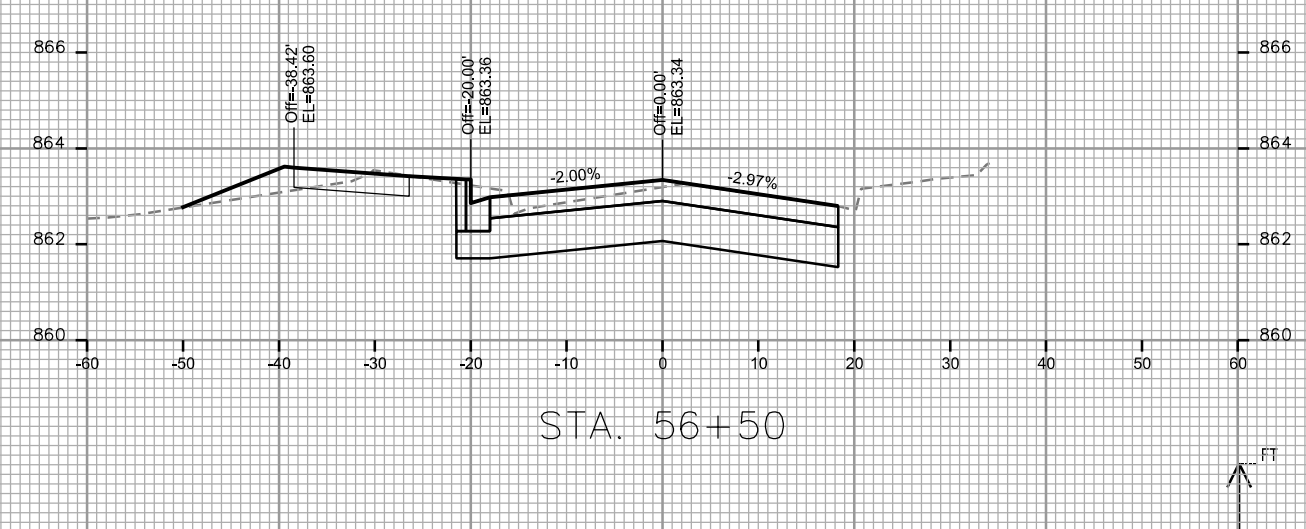
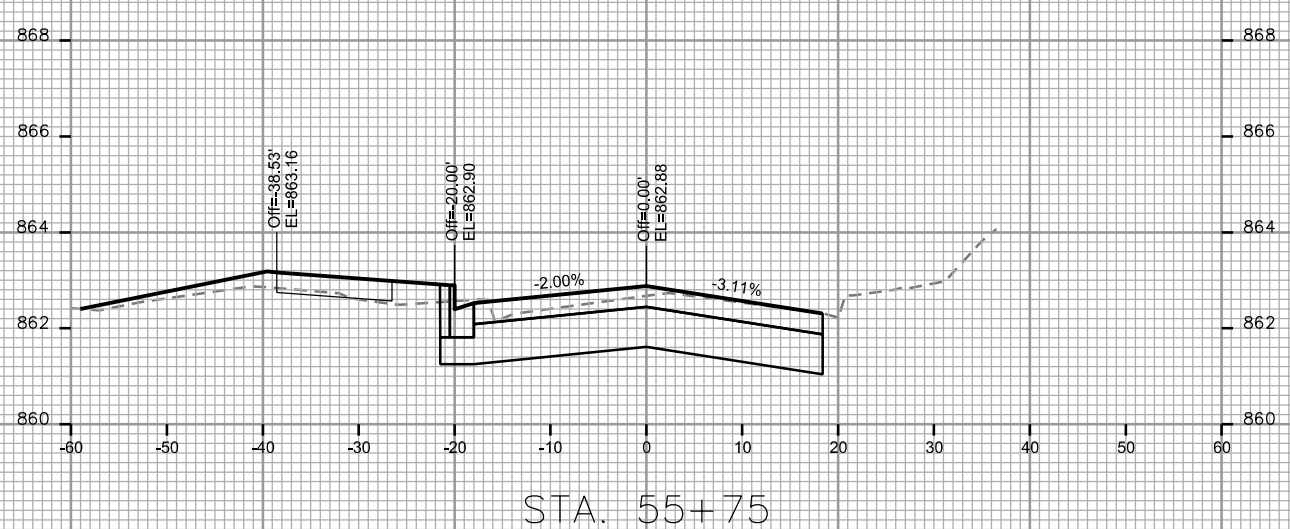
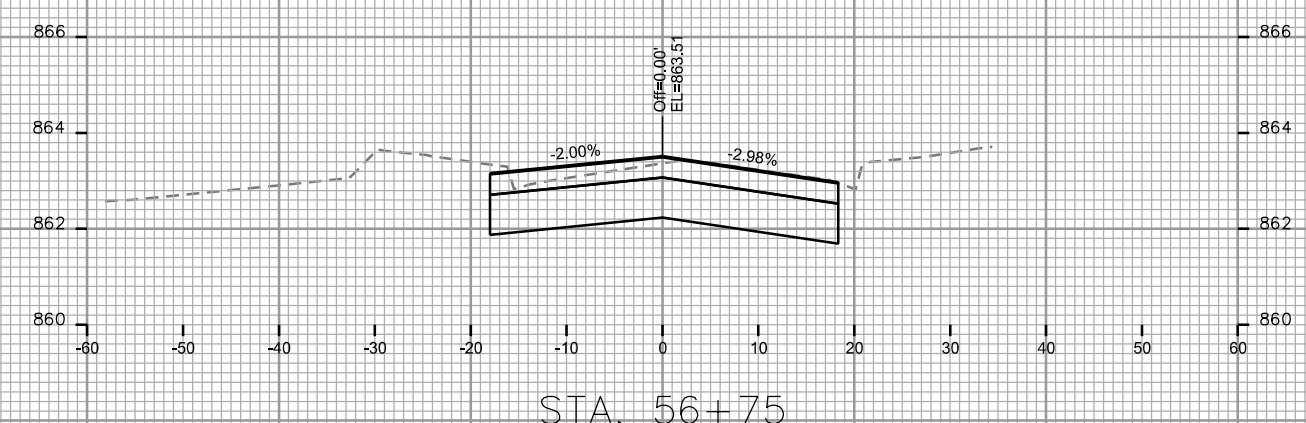
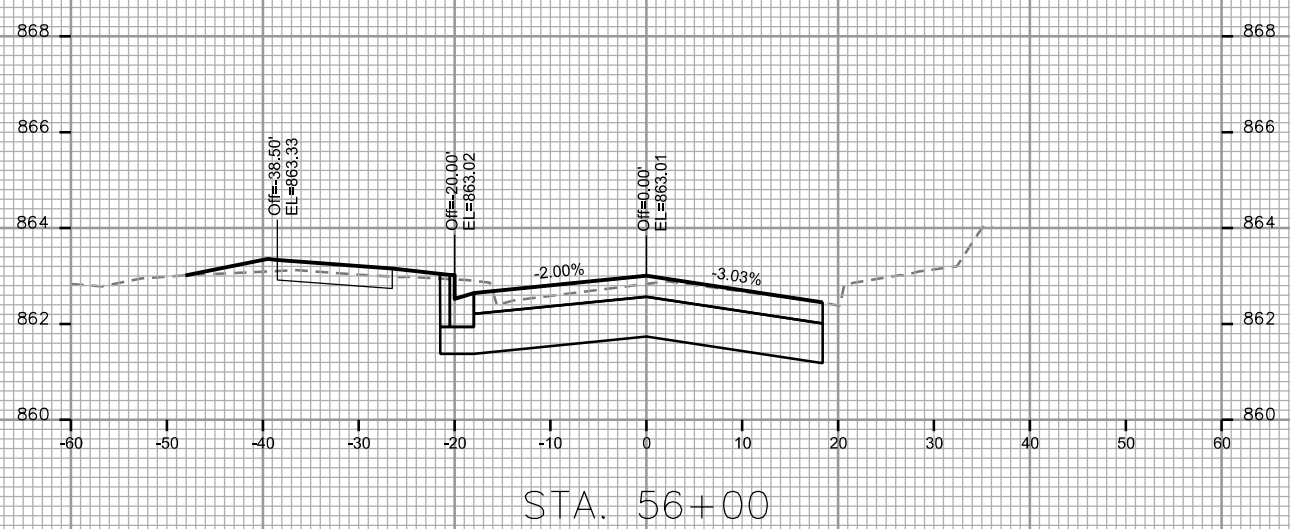
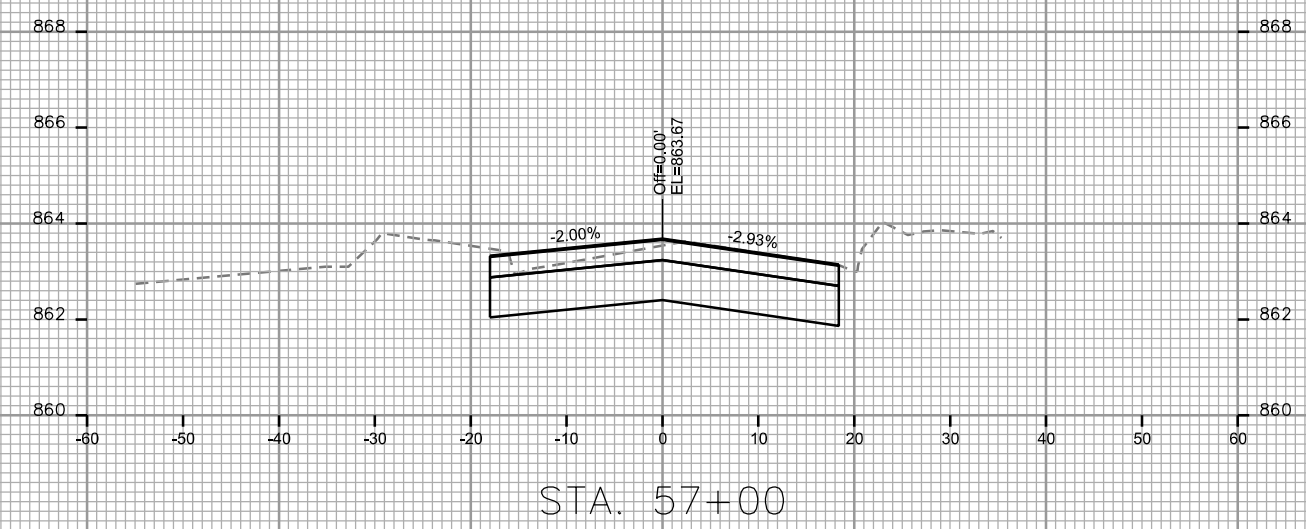
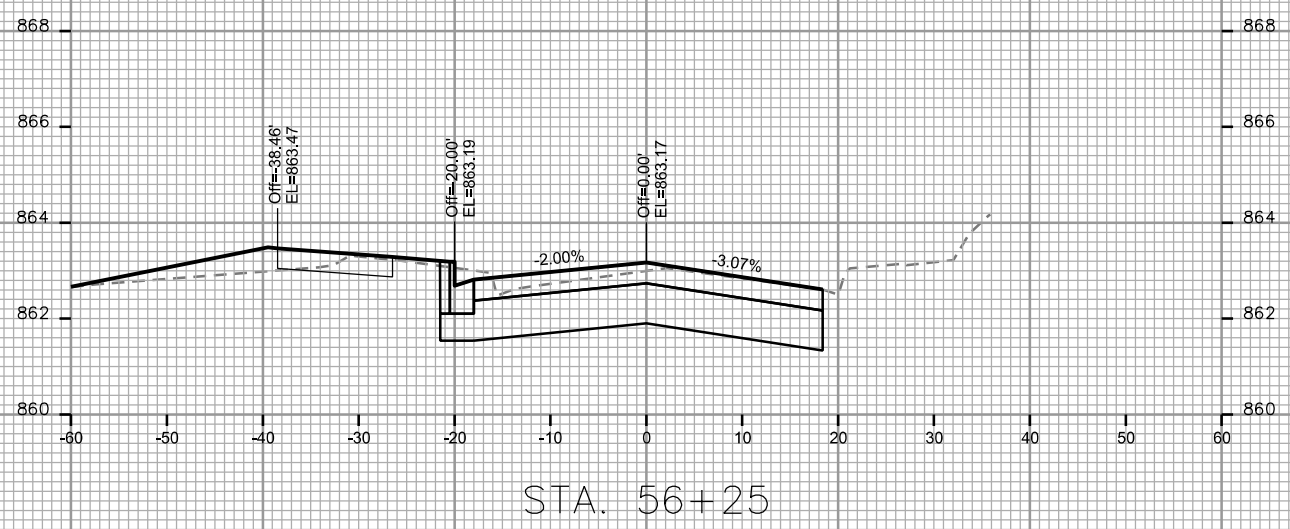

CROSS SECTIONS
DEMPSEY ROAD CITY OF MADISON

PLOT SCALE: _____

PLOT NAME: _____

REV. DATE: _____

ORIGINATOR: CITY OF MADISON, STREETS DIVISION

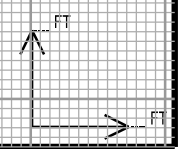
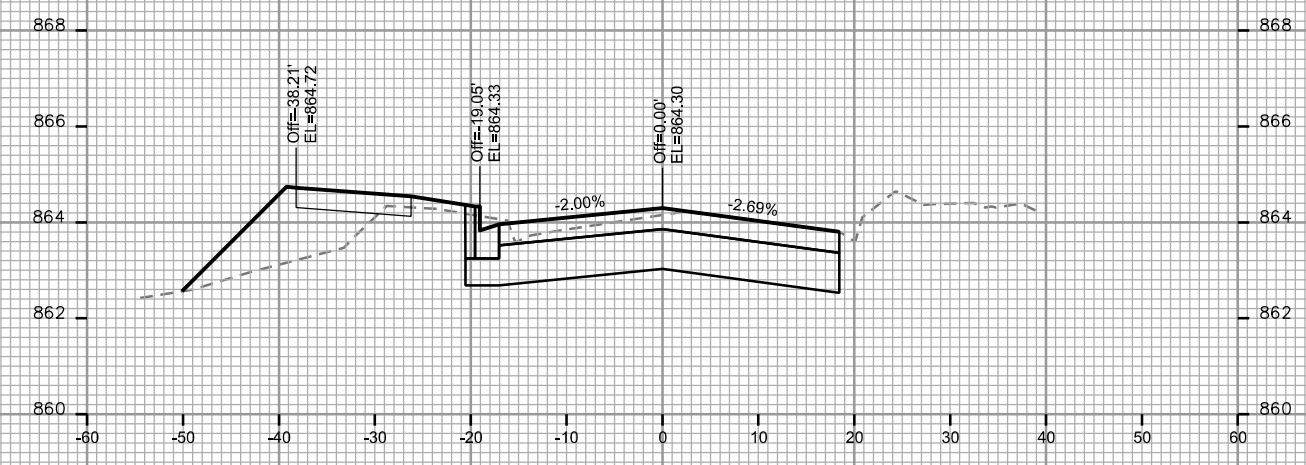
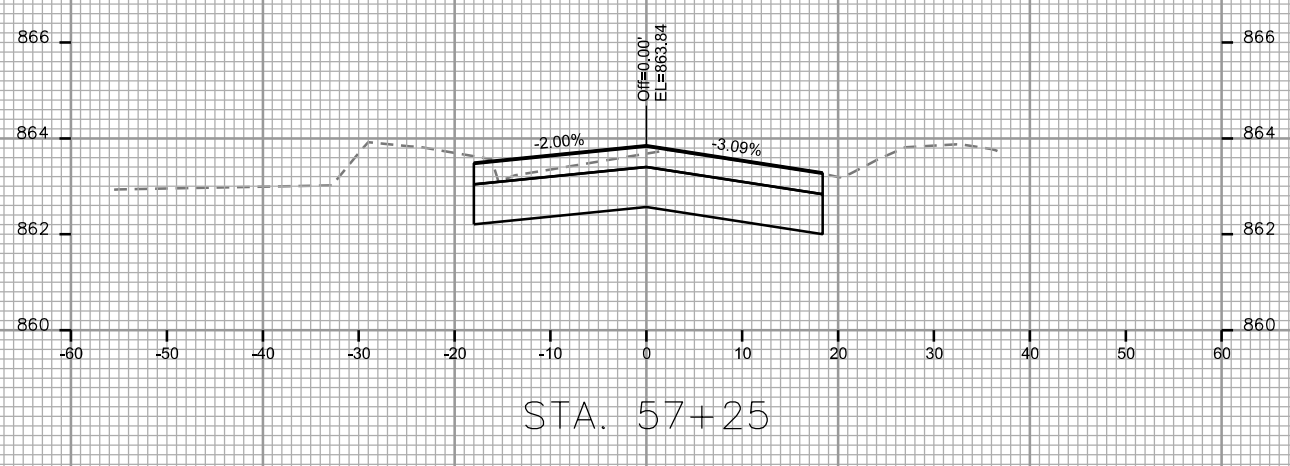
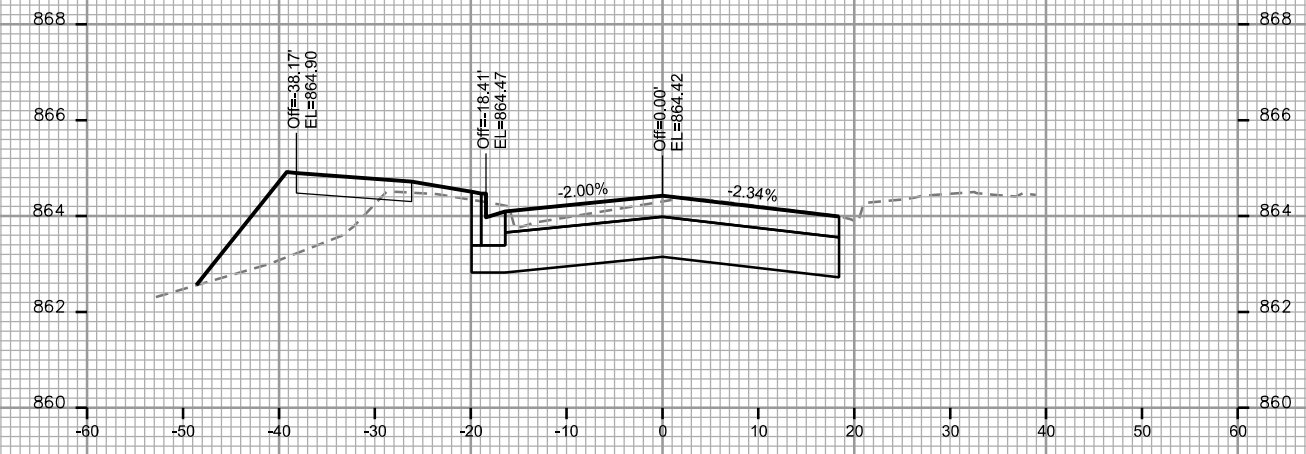
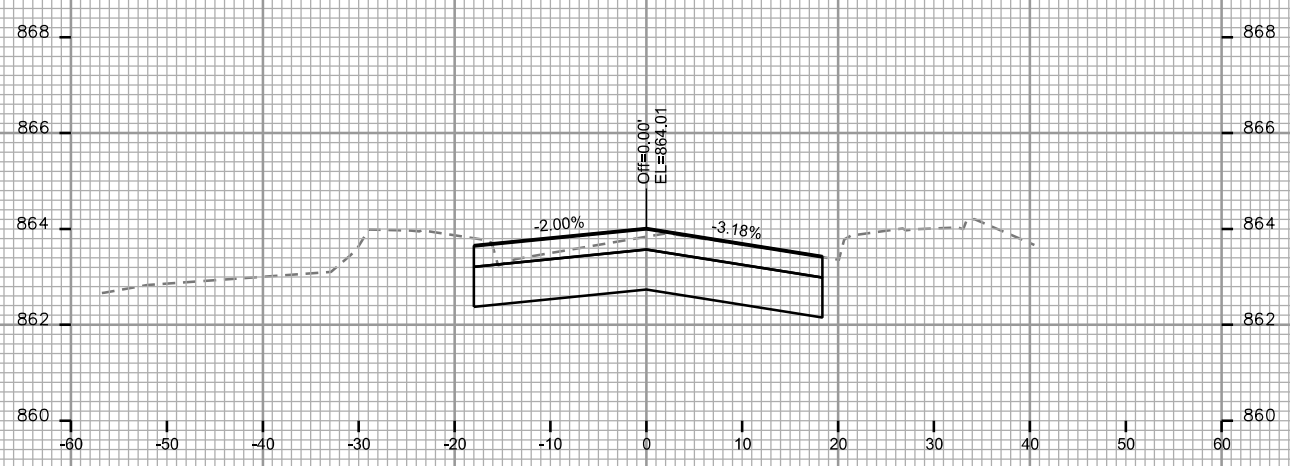
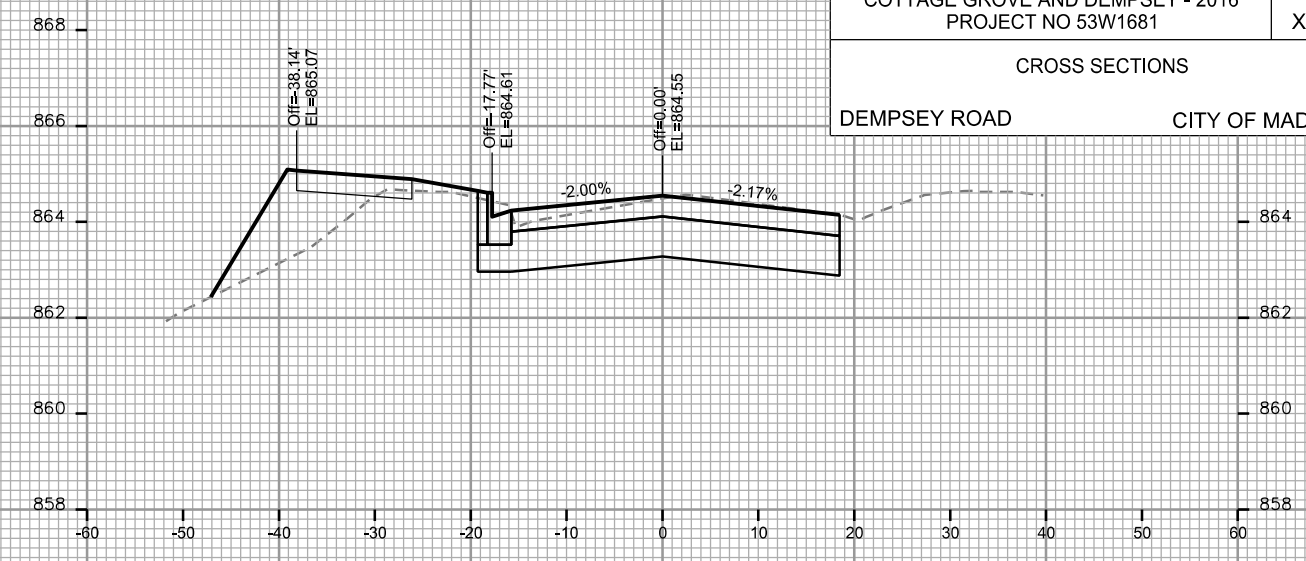
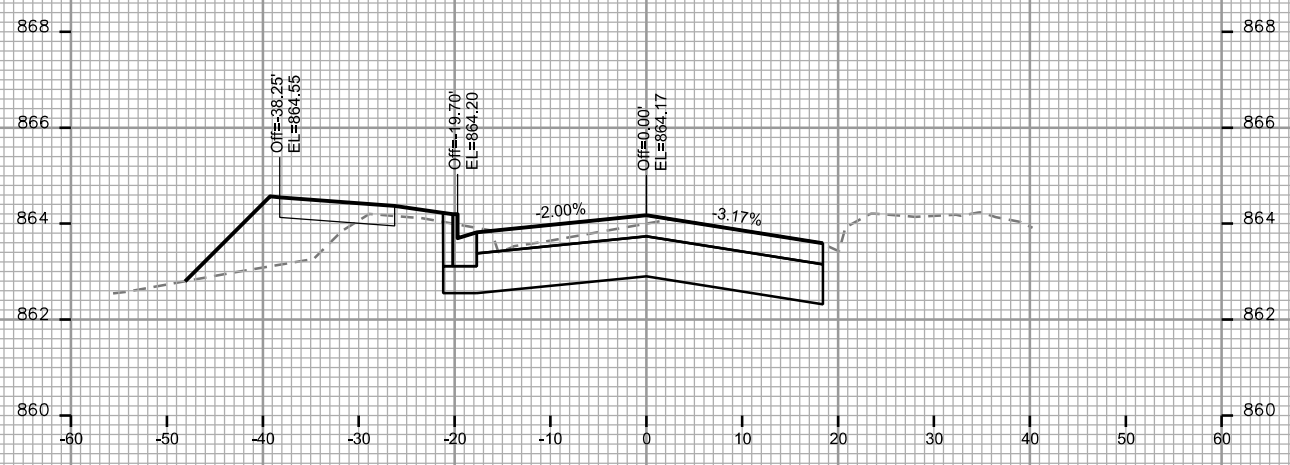

PLOT SCALE: _____

PLOT NAME: _____

REV. DATE: _____

ORIGINATOR: CITY OF MADISON STREETS DIVISION

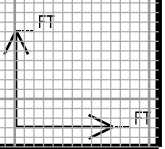
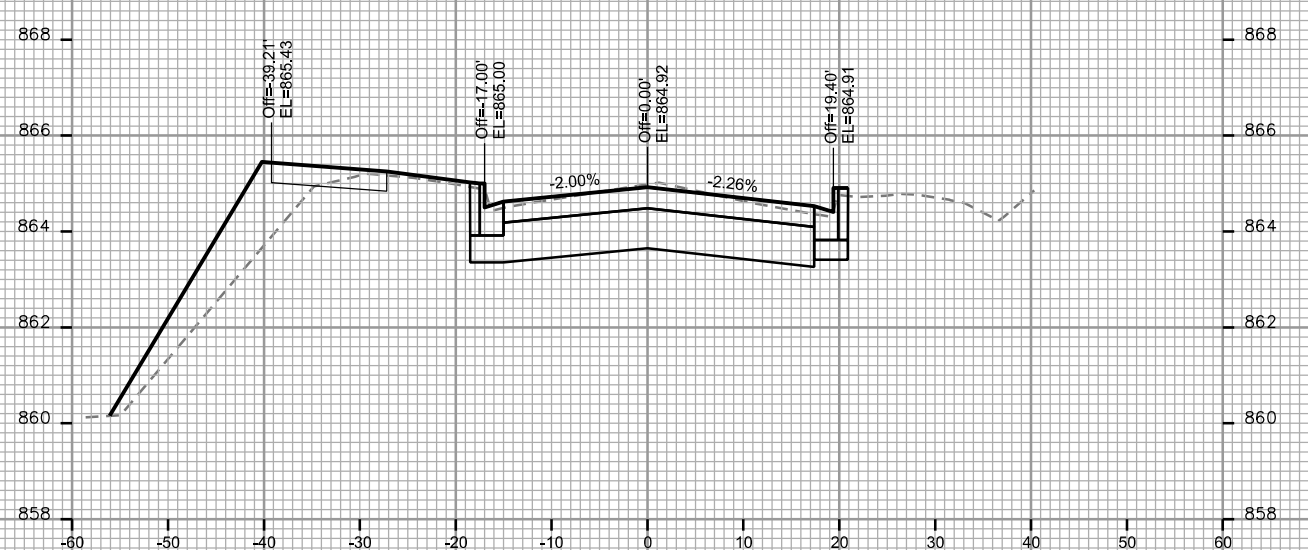
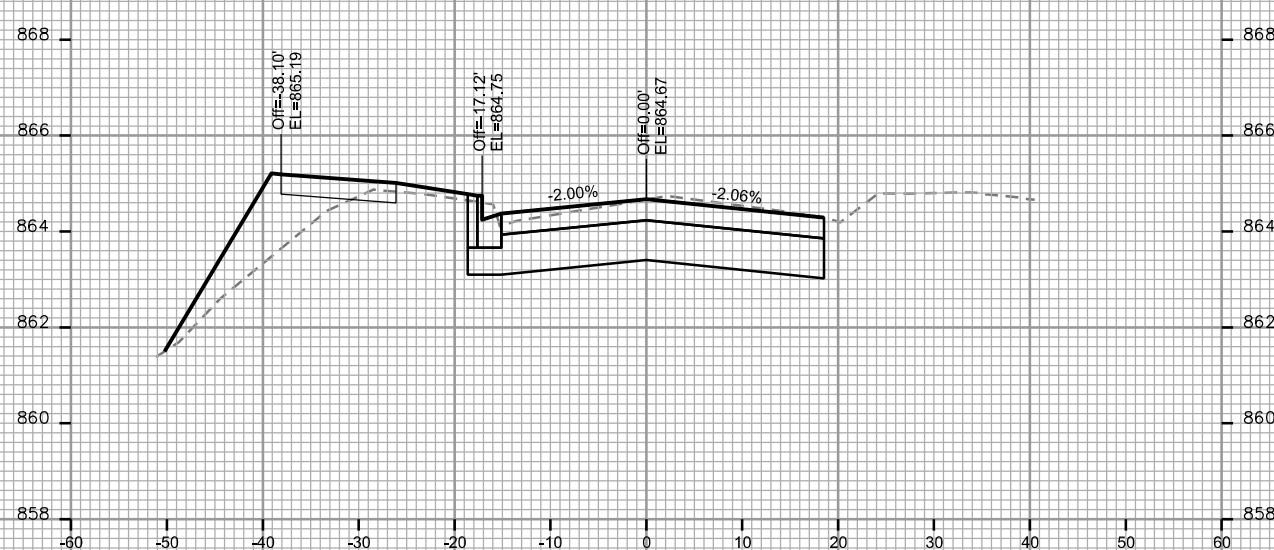
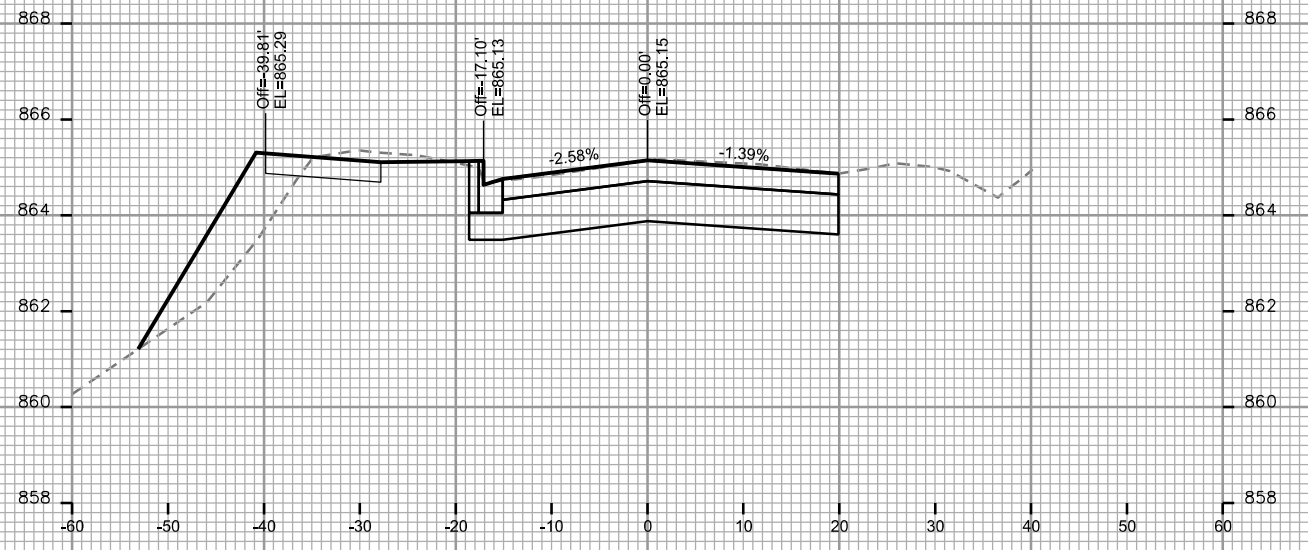
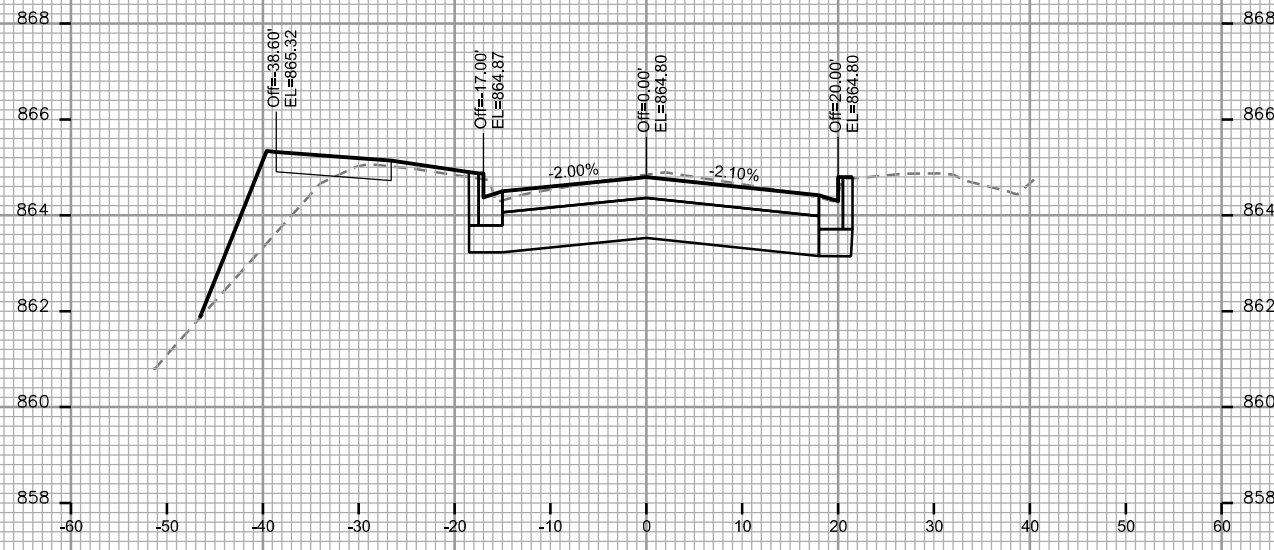

CROSS SECTIONS
DEMPSEY ROAD CITY OF MADISON

PLOT SCALE: _____

PLOT NAME: _____

REV. DATE: _____

ORIGINATOR: CITY OF MADISON - STREETS DIVISION

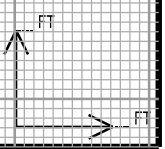
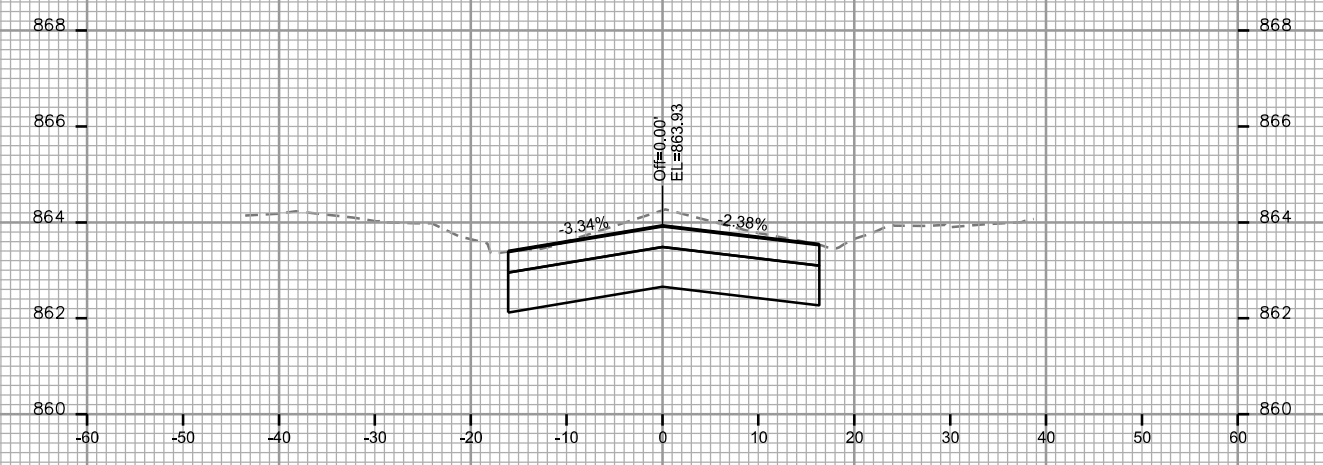
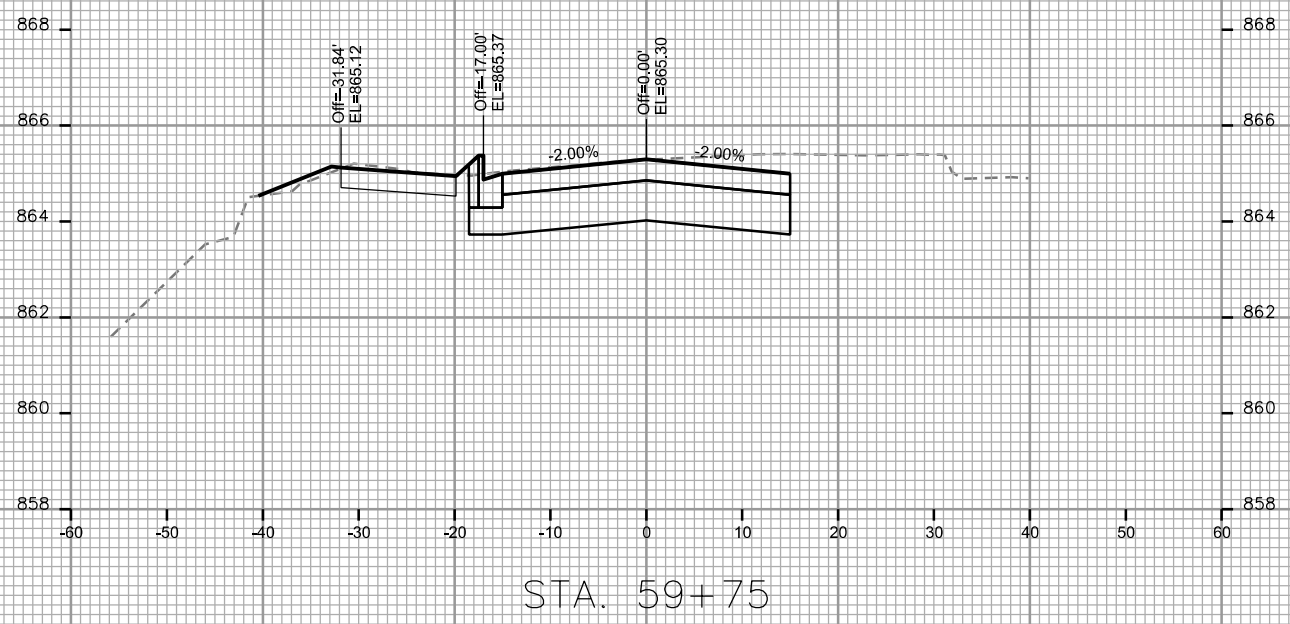
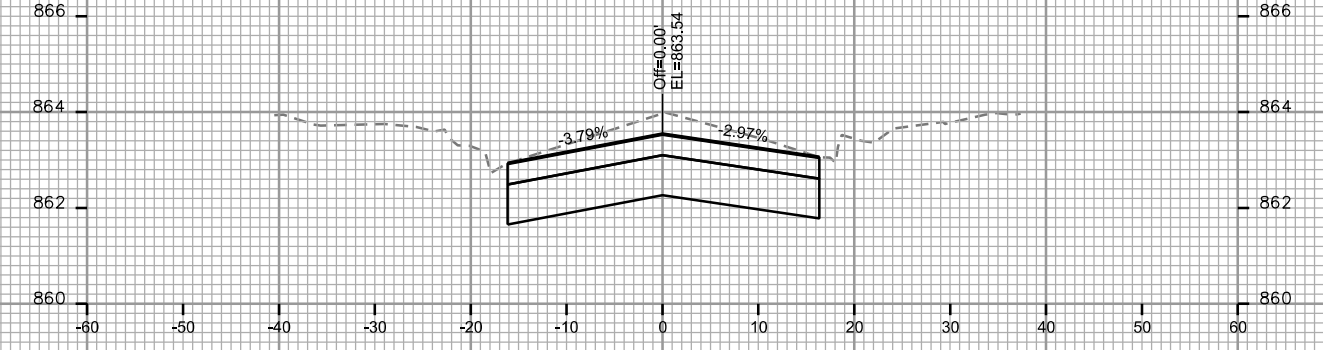
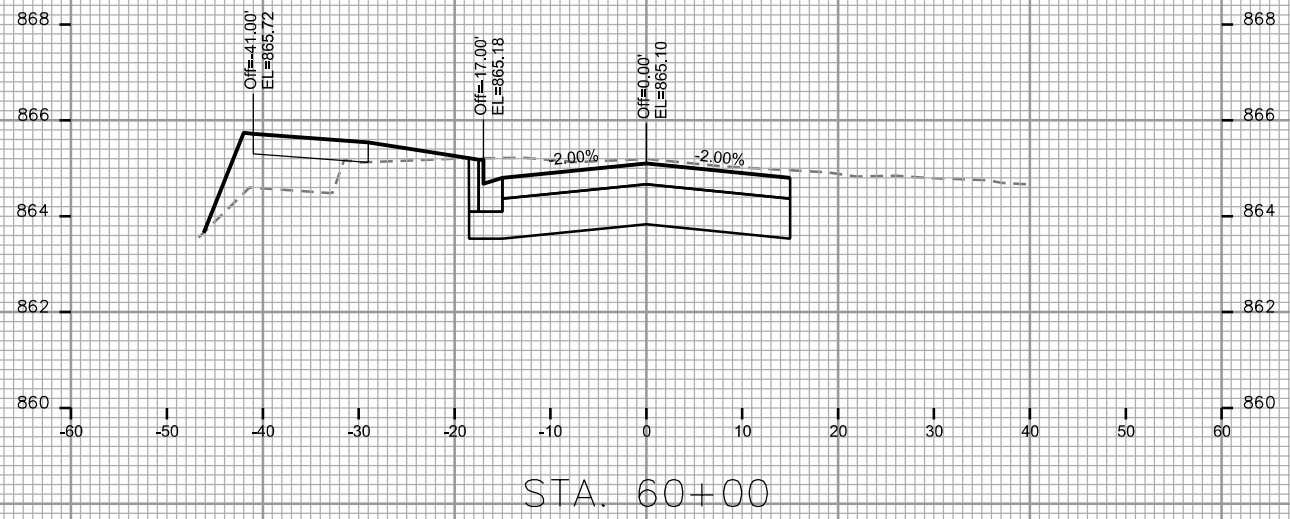
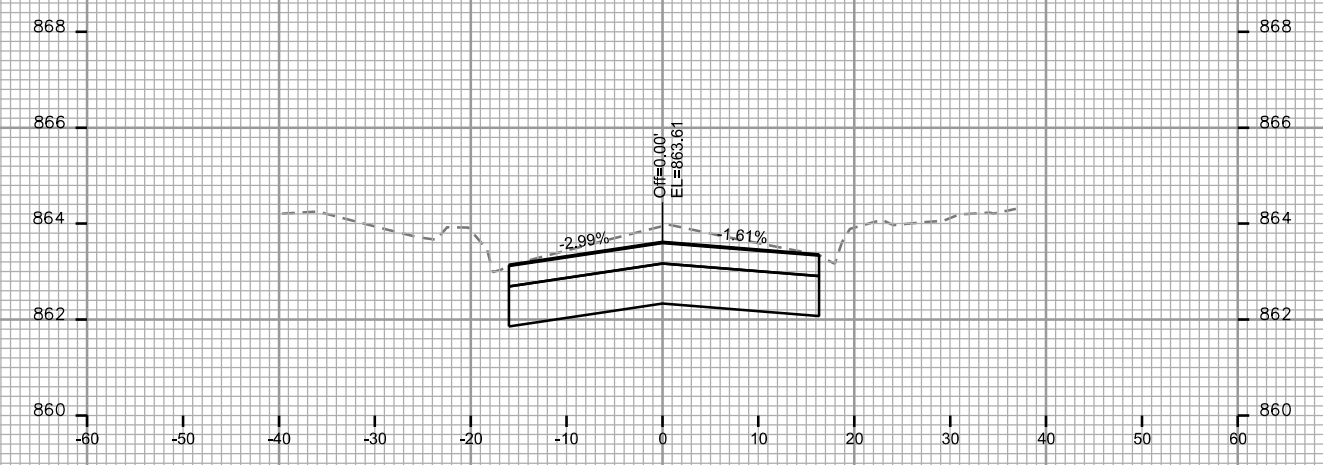
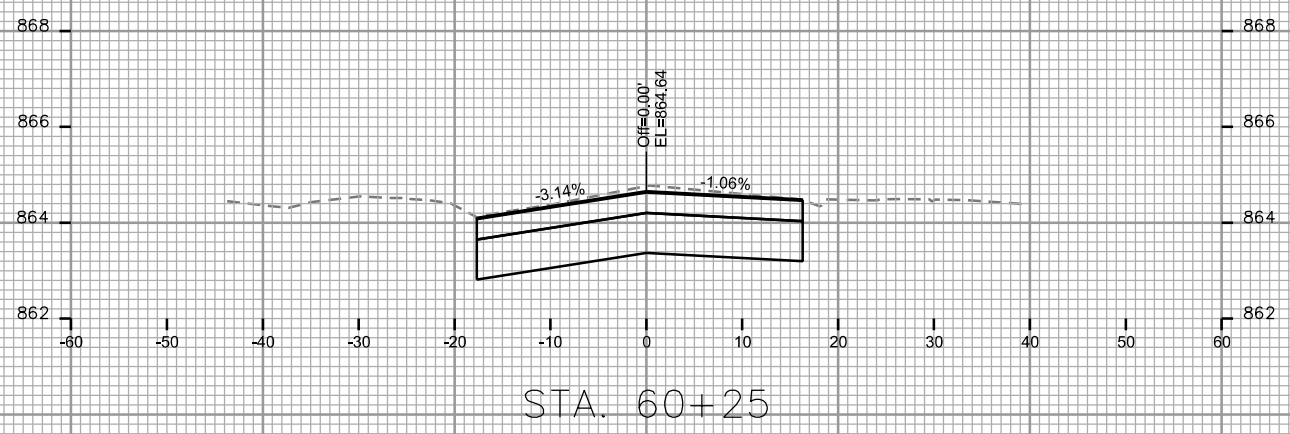

CROSS SECTIONS
DEMPSEY ROAD CITY OF MADISON

PLOT SCALE: _____

PLOT NAME: _____

REV. DATE: _____

ORIGINATOR: CITY OF MADISON - STREETS DIVISION

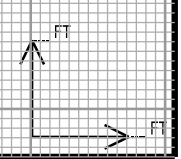
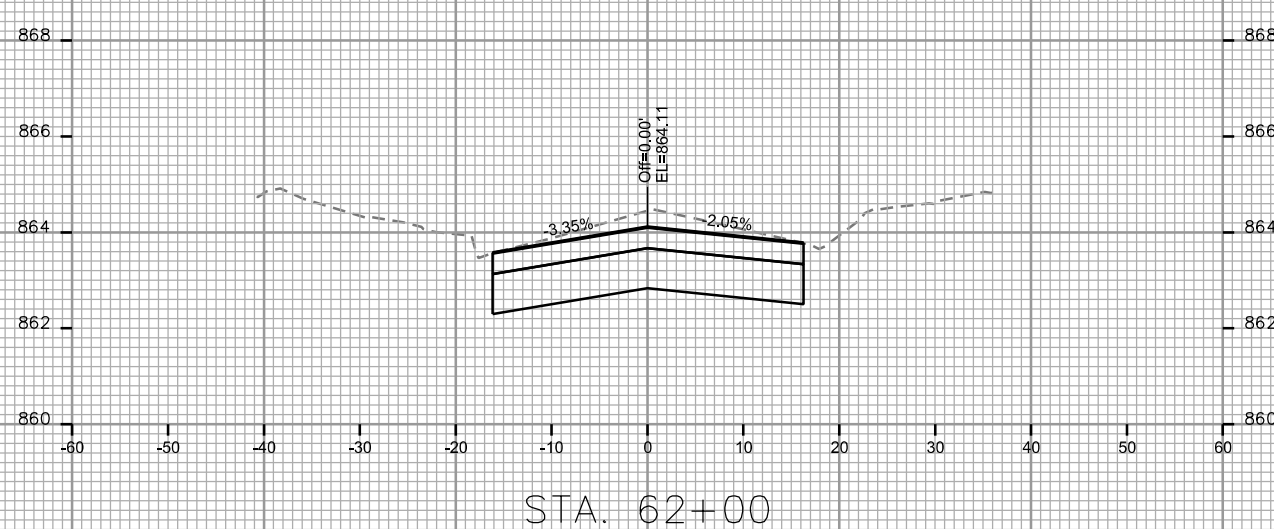
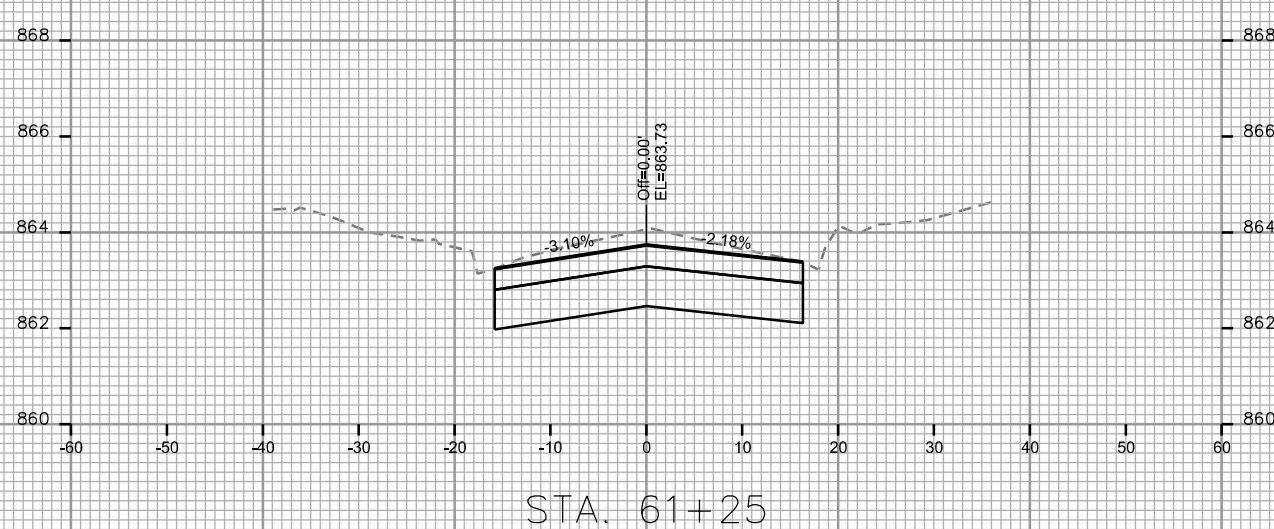
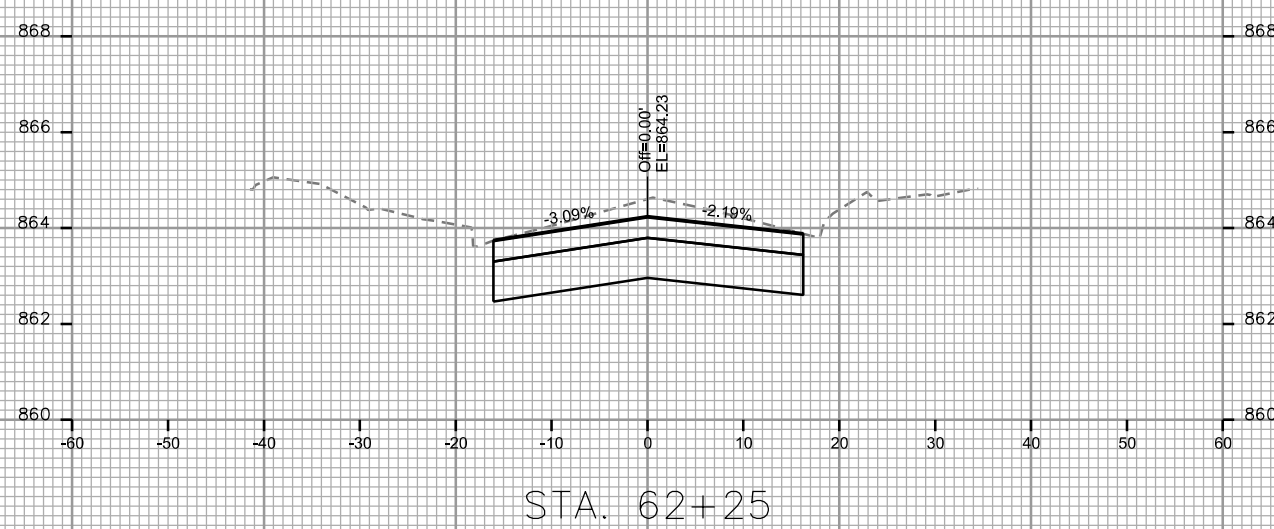
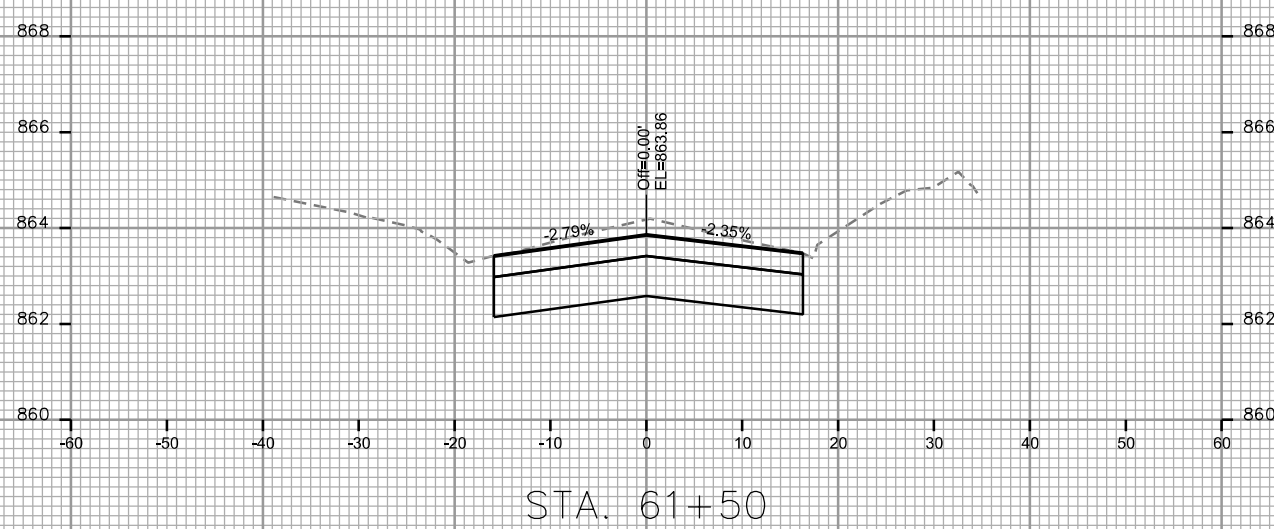
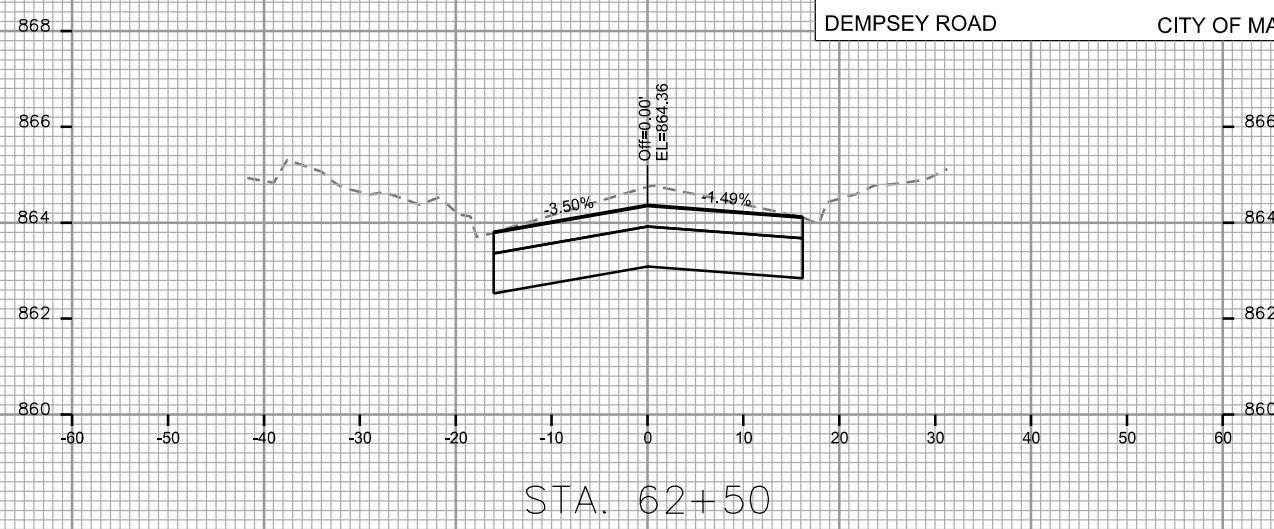
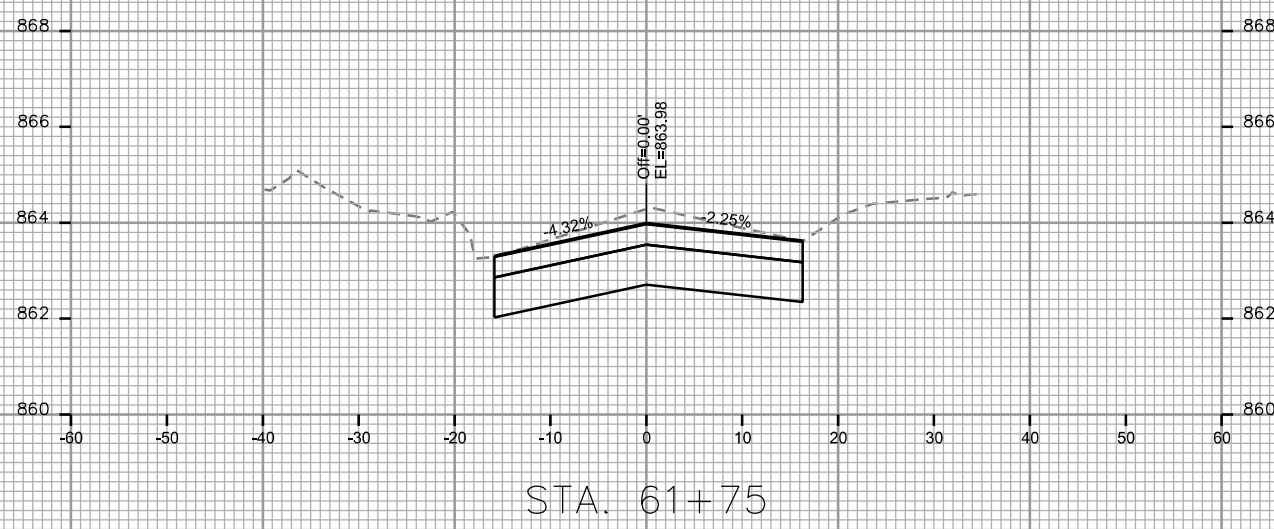

CROSS SECTIONS

DEMPSEY ROAD CITY OF MADISON

PLOT SCALE: _____

PLOT NAME: _____

REV. DATE: _____

ORIGINATOR: CITY OF MADISON, STREETS DIVISION

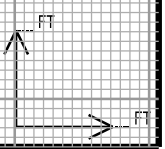
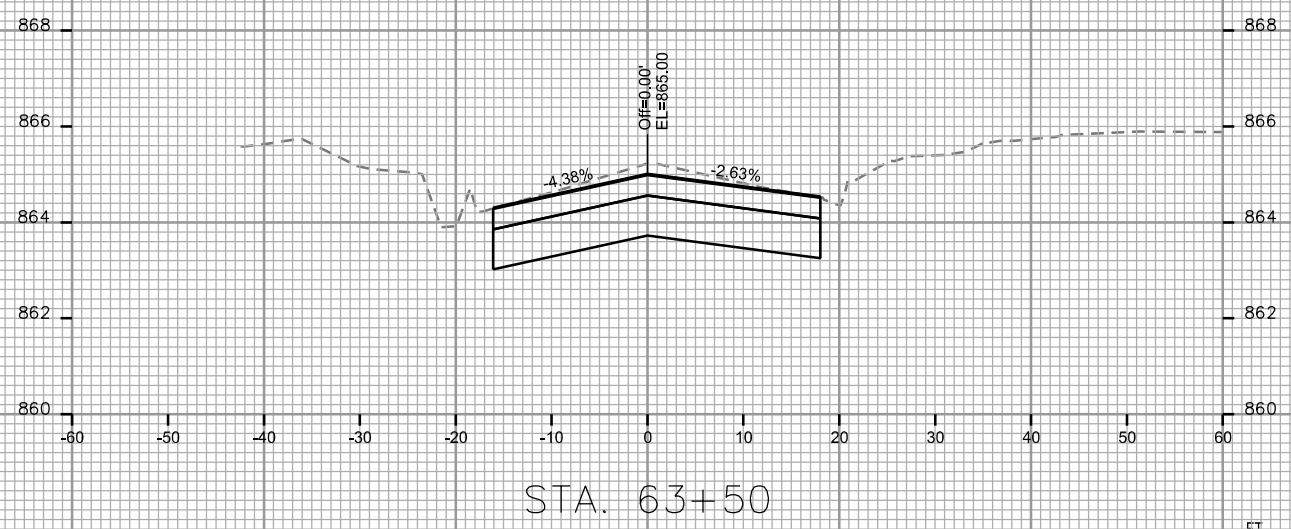
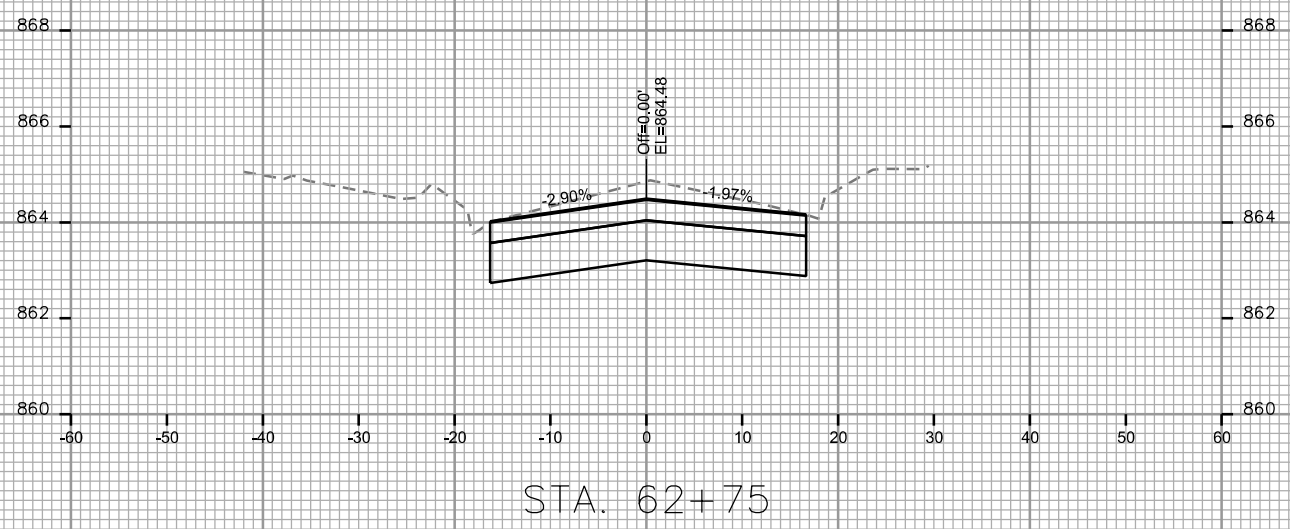
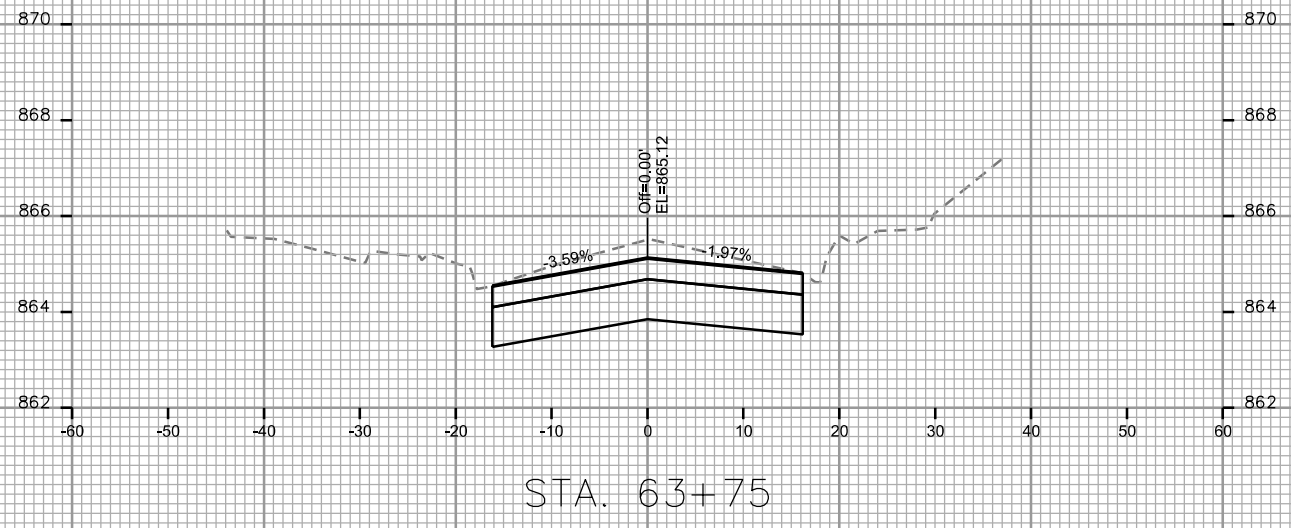
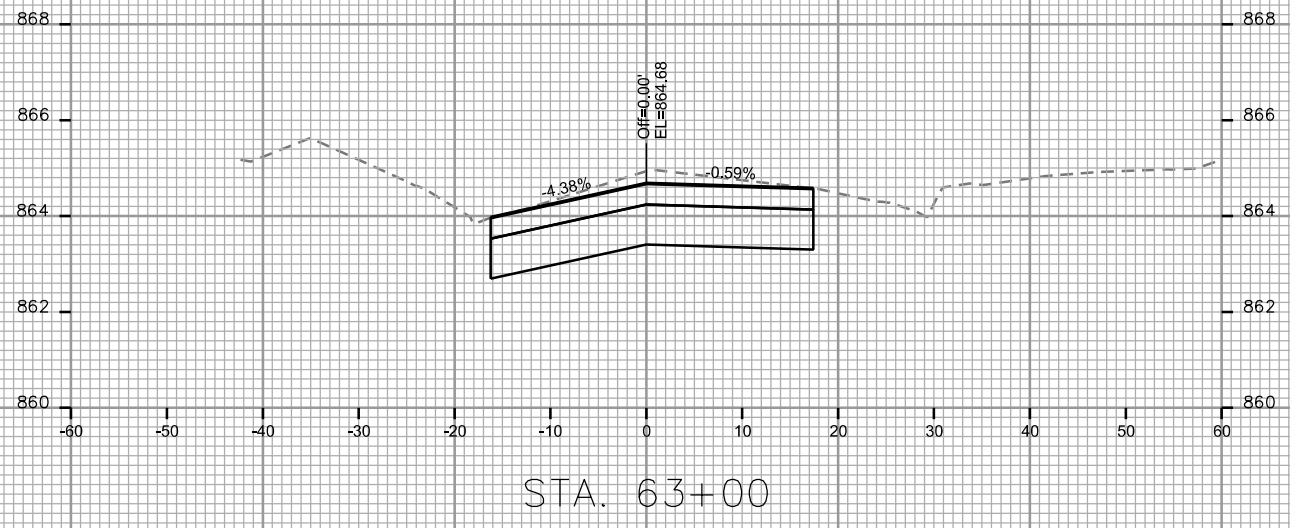
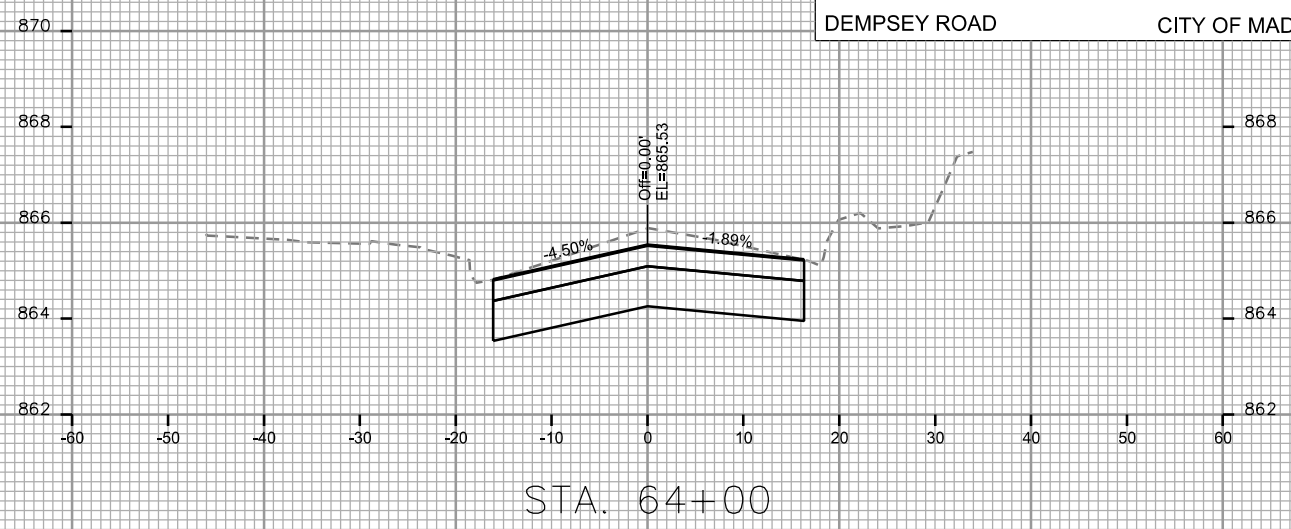
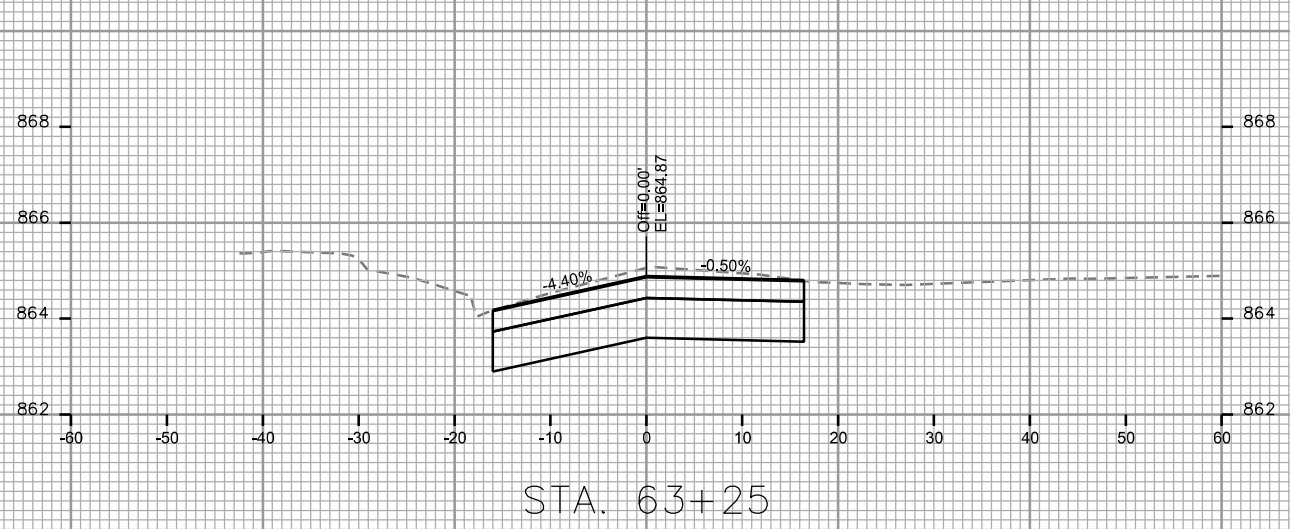

PLOT SCALE: _____

PLOT NAME: _____

REV. DATE: _____

ORIGINATOR: CITY OF MADISON - STREETS DIVISION

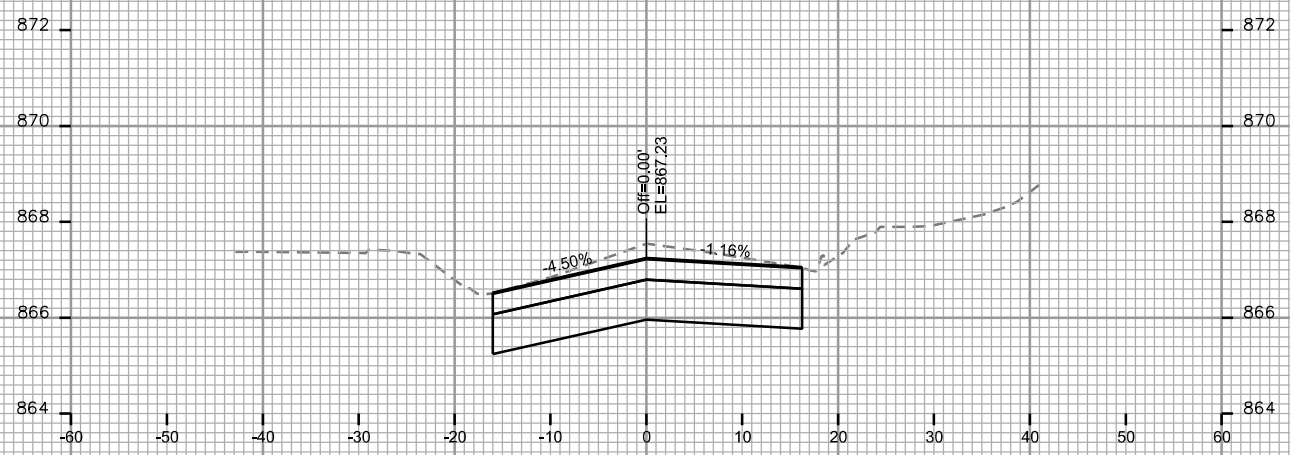

STA. 64+75

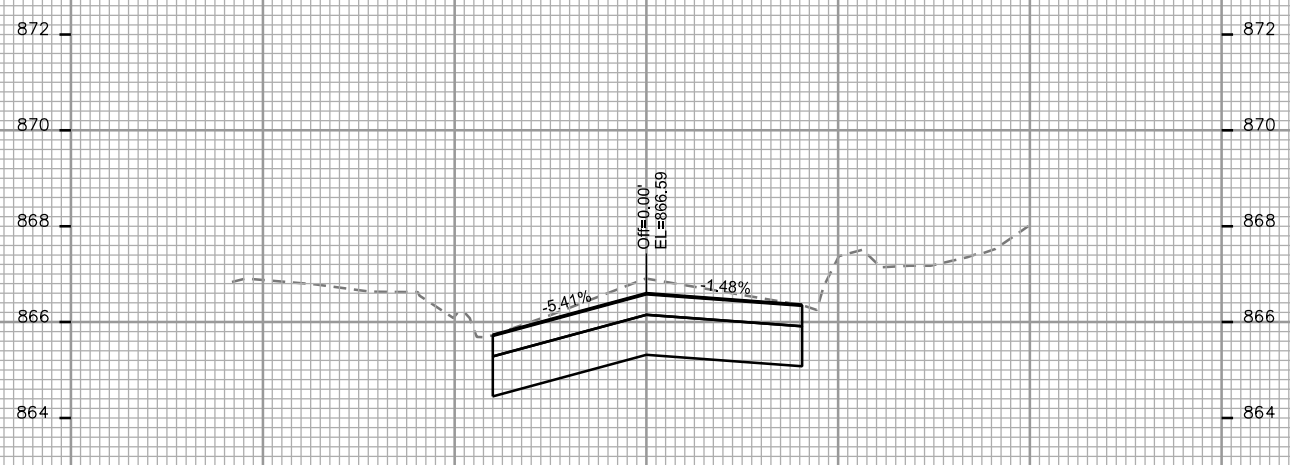

STA. 64+50

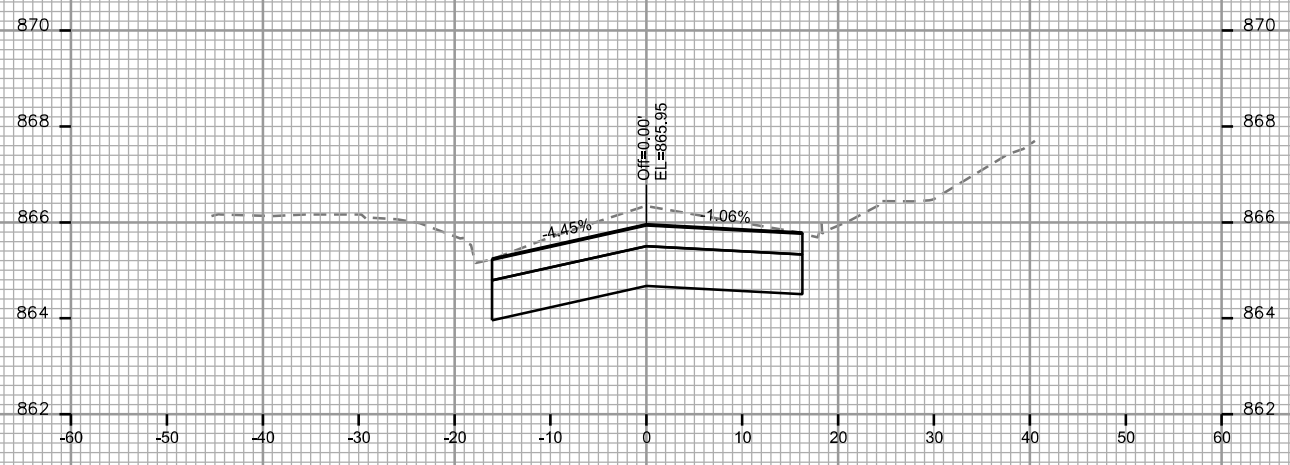

STA. 64+25

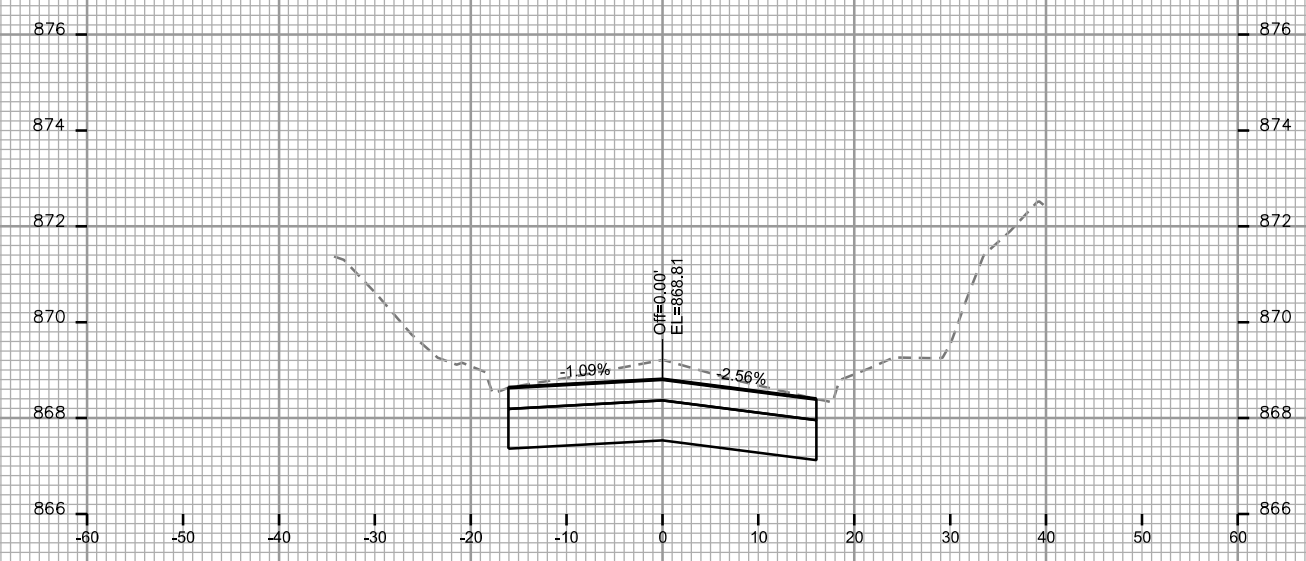

STA. 65+25

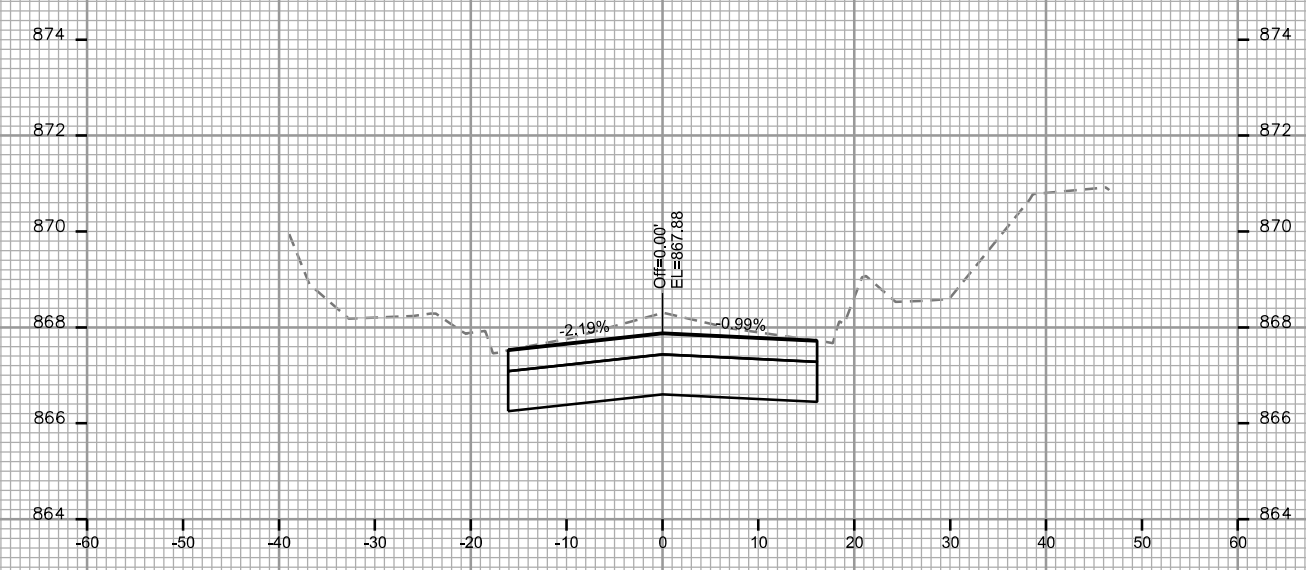

STA. 65+00

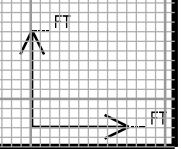

PLOT SCALE: _____

PLOT NAME: _____

REV. DATE: _____

ORIGINATOR: CITY OF MADISON, STREETS DIVISION

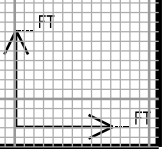
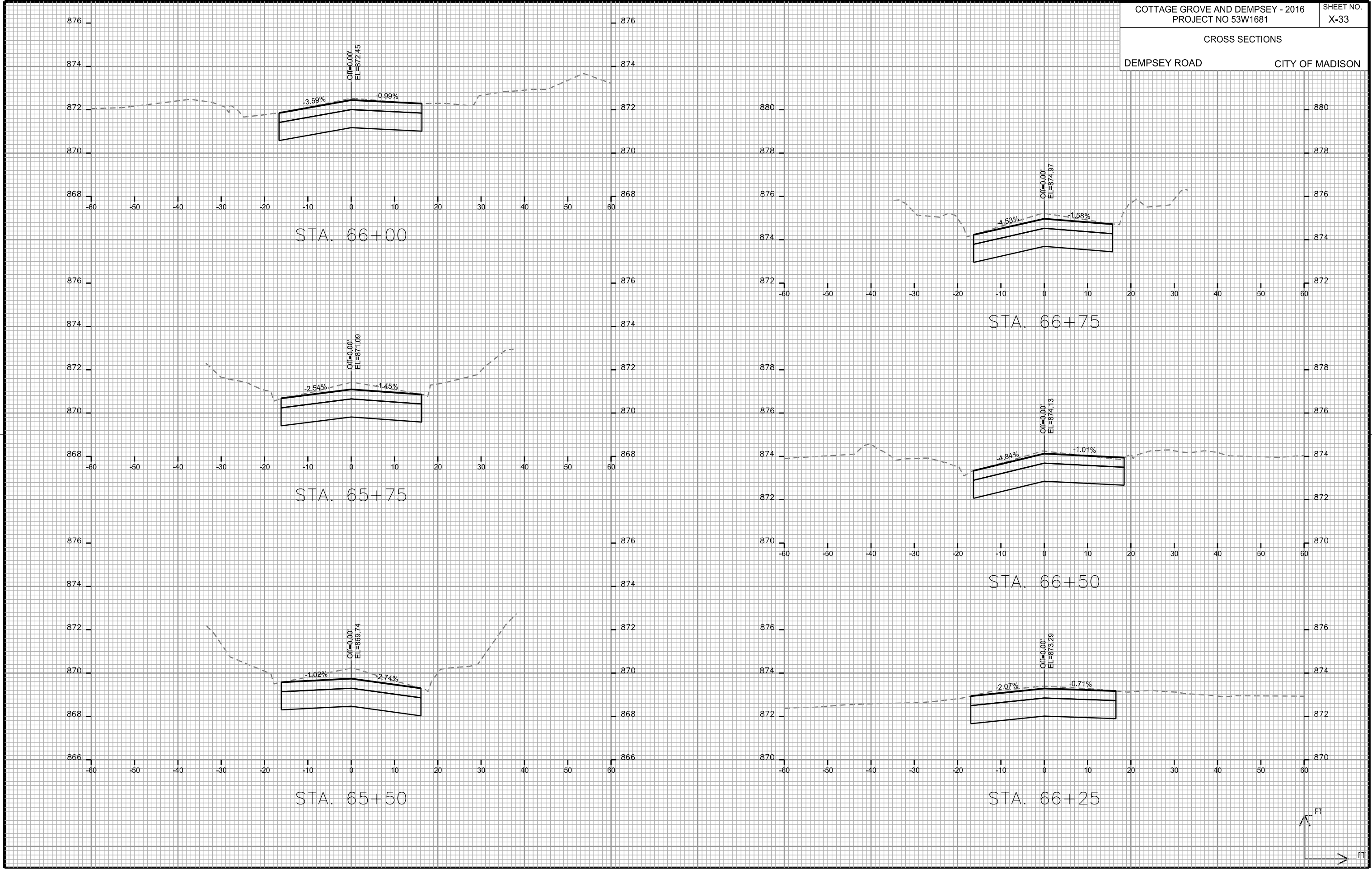

CROSS SECTIONS
DEMPSEY ROAD CITY OF MADISON

PLOT SCALE: _____

PLOT NAME: _____

REV. DATE: _____

ORIGINATOR: CITY OF MADISON, STREETS DIVISION

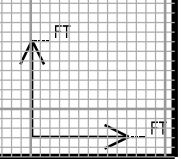
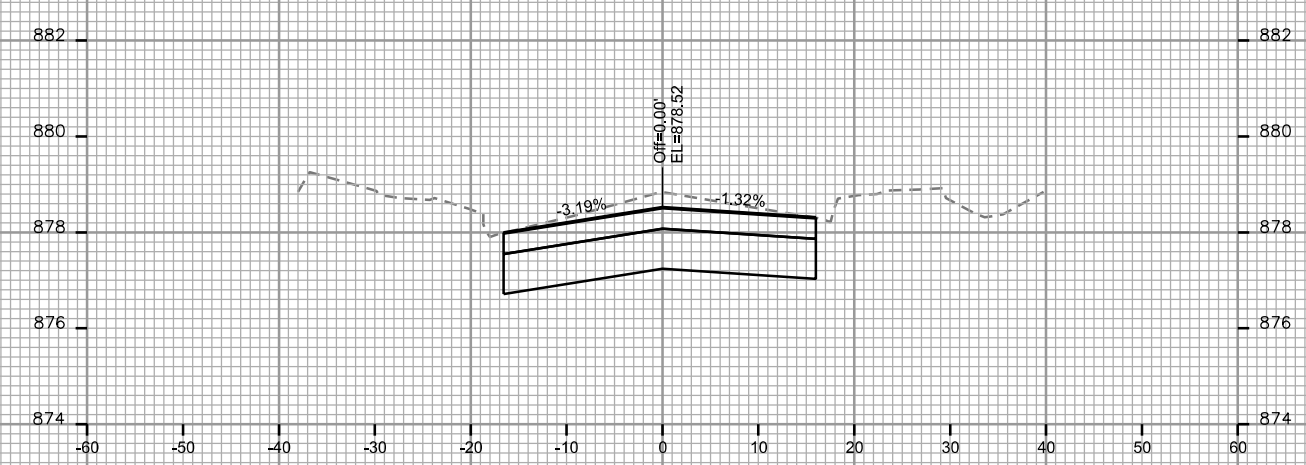
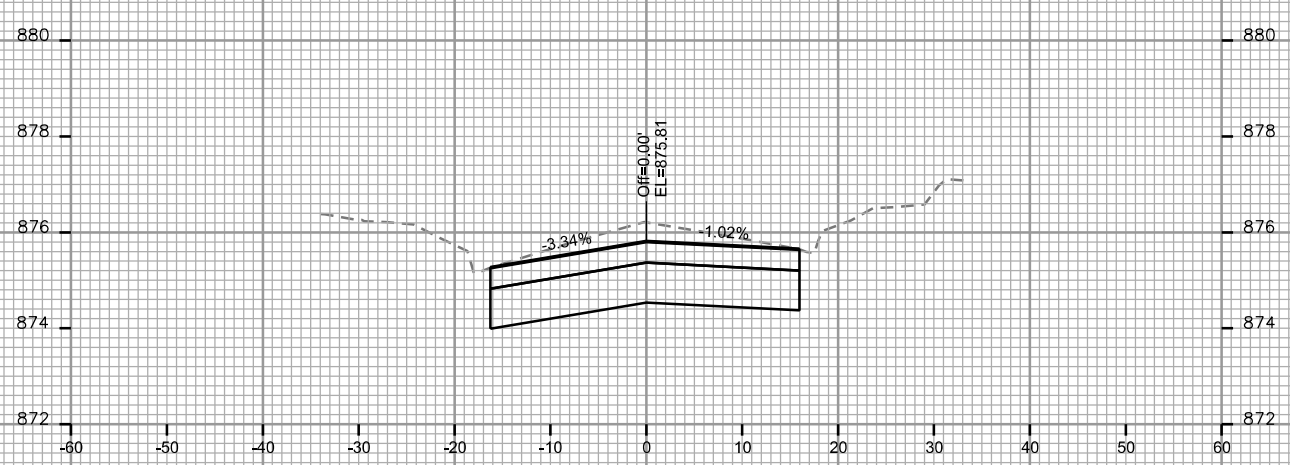
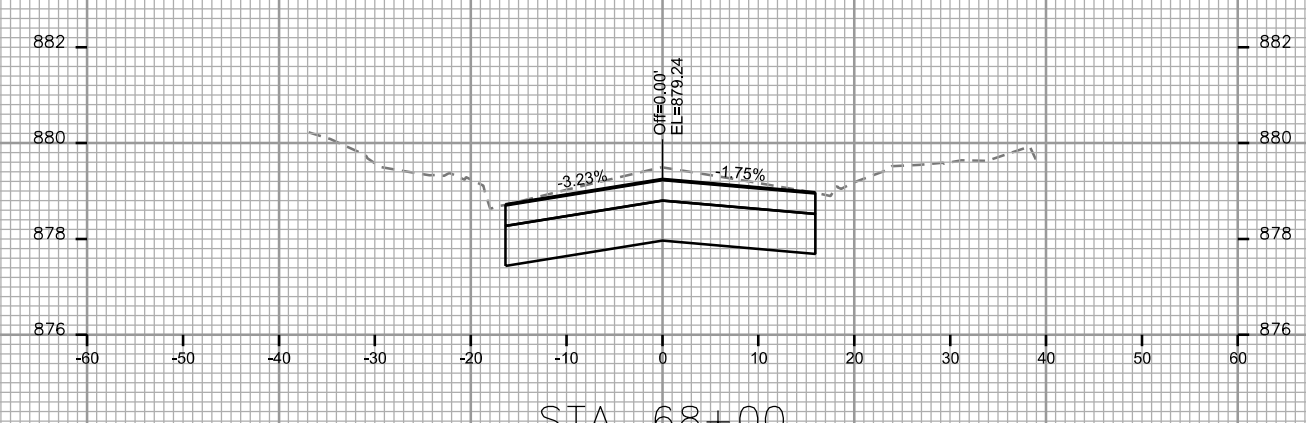
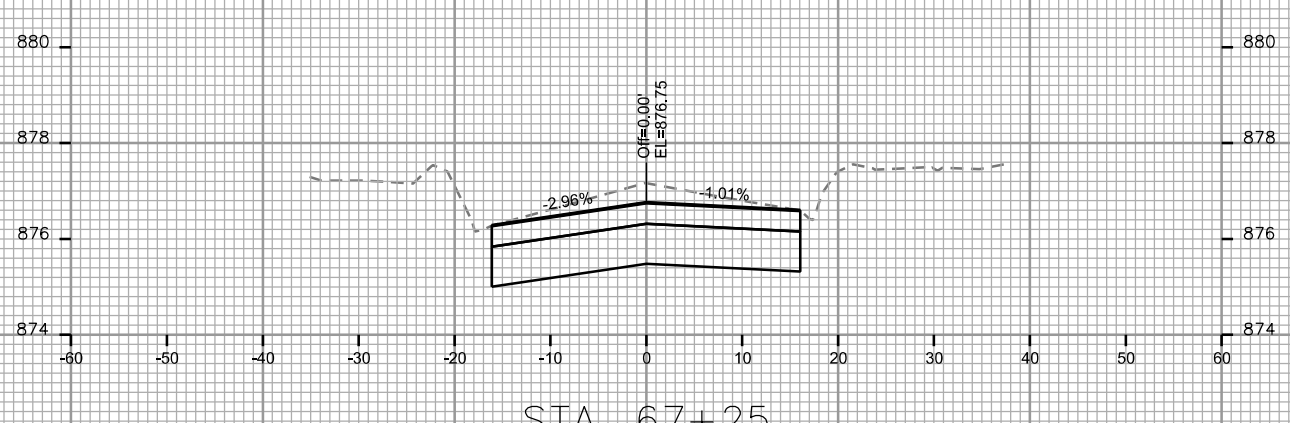
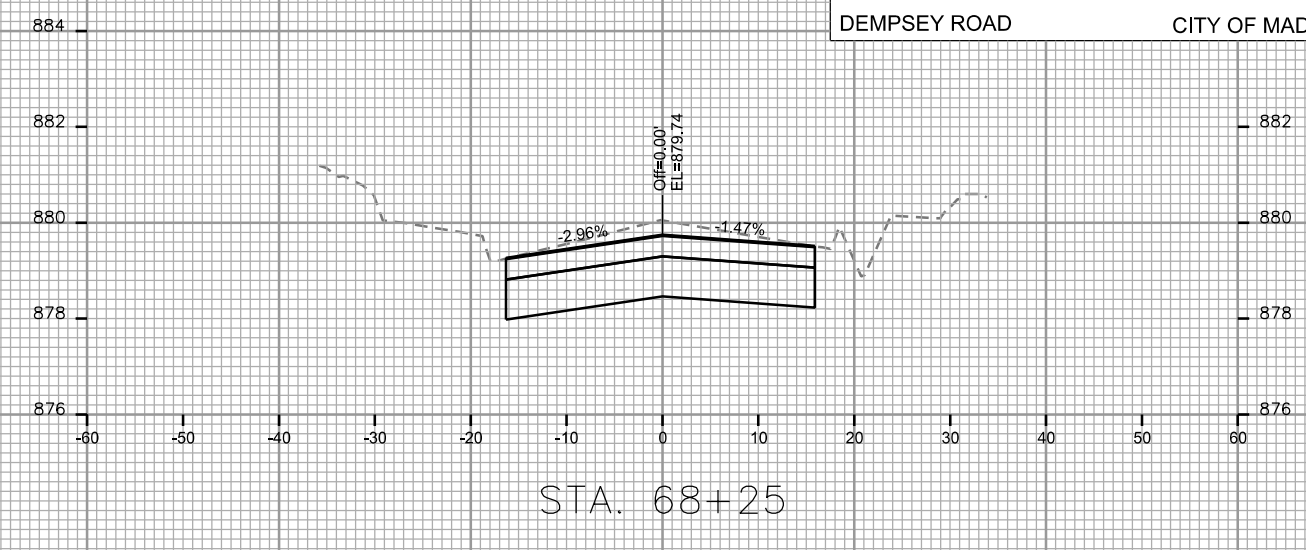
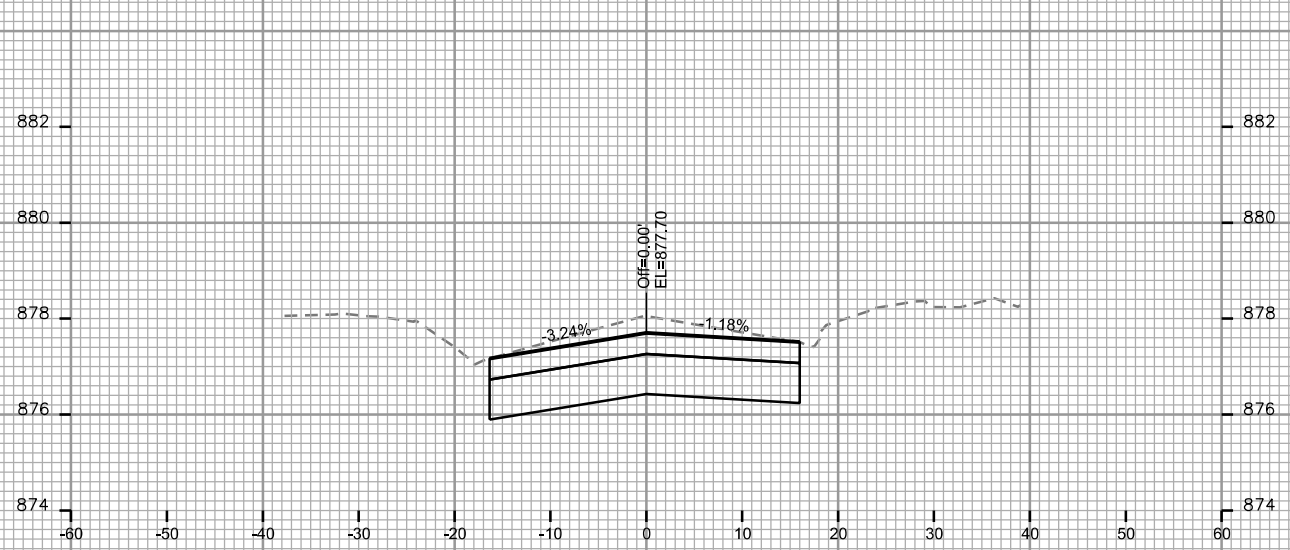

CROSS SECTIONS
DEMPSEY ROAD CITY OF MADISON

PLOT SCALE: _____

PLOT NAME: _____

REV. DATE: _____

ORIGINATOR: CITY OF MADISON, STREETS DIVISION

